

Truma UltraRapid

LPG and 230 V / 240 V Electric Storage Water Heater



Operating instructions

To be kept in the vehicle



More comfort on the move

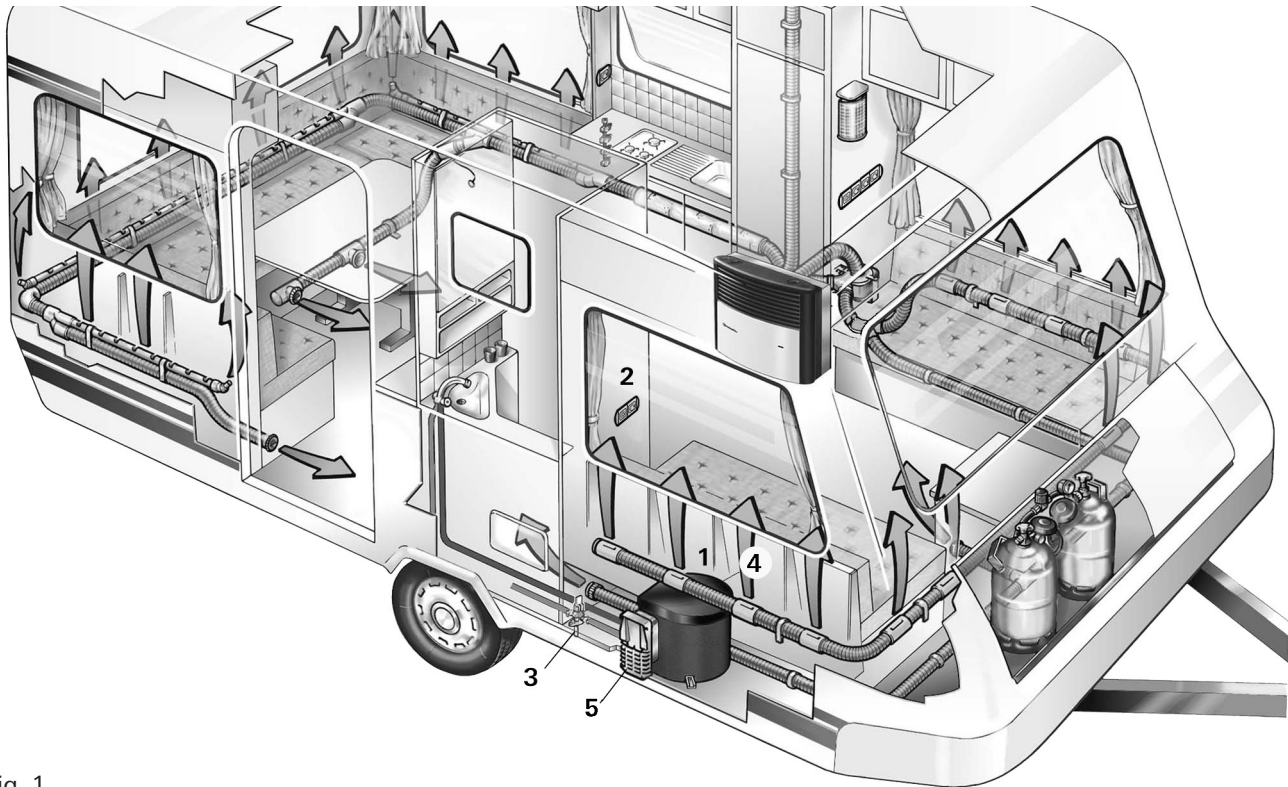

Fig. 1

Table of contents

Symbols used	2
Model	2
General safety notes	2
Operating instructions	
Filling the Truma UltraRapid with water	4
Pressure and Temperature Relief Valve (P&T safety valve)	4
Draining the water heater	4
Switching on gas operation	5
Removing the cowl cover	5
Select water heater mode	5
Switching off gas operation	5
Red indicator lamp "Fault"	5
Electrical operation 230 V ~ / 240 V ~ - option -	5
Maintenance	5
Decalcification	5
Fuses	6
Fault finding	6
Technical data	7
Truma warranty policy	7
Wiring Diagram	10

Installation example

- | | |
|---|--|
| 1 | Truma UltraRapid |
| 2 | Control panel |
| 3 | Drain valve |
| 4 | Pressure and Temperature Relief Valve (P&T safety valve) |
| 5 | Cowl for combustion air intake and exhaust gas discharge |

General safety notes

The use of upright gas cylinders from which gas is taken in the gas phase is mandatory for the operation of gas regulators, gas equipment and gas systems. Gas cylinders from which gas is taken in the liquid phase (e. g. for fork lifts) must not be used, since they would result in damage to the gas system.

In the event of leaks in the gas system or if there is a smell of gas:

- extinguish all naked flames
- do not smoke
- switch off all appliances
- shut off the gas cylinder
- open the windows and doors
- do not actuate any electrical switches
- have the entire system checked by an expert!

– Repairs may only be carried out by an expert.

– Do not use this appliance as a pool heater.

Symbols used



The device must only be installed and repaired by an expert.



Symbol indicates a possible hazard.



Note containing information and tips.

Model

Truma UltraRapid Gas (BGA 14)
Truma UltraRapid Gas/Electric (BGEA 14)

- This device may be used by children aged 8 years or above and by persons with reduced physical, sensory or mental capabilities or lack of experience and / or knowledge, only if they are supervised or have been given instruction with regard to the safe use of the device and have understood the potential risks. Children must not use the device as a toy.
 - To avoid the risk of accidental resetting of the over-temperature guard, the device may not be supplied with power via an external contactor, such as a timer, nor may it be connected to a power circuit that is regularly switched on or off via a device.
- Danger** – Failure to operate the P&T safety valve (Fig. 1 - 4) at least once every six months may result in the water heater splitting. Continuous leakage of water from the valve may indicate a problem with the water heater!
- Water may drip from the discharge pipe of the P&T safety valve and this pipe must be left open to the atmosphere.
 - The P&T safety valve is to be operated regularly to remove lime deposits and to ensure that it is not blocked.
 - Any discharge pipe connected to the P&T safety valve is to be installed in a continuously downward direction and in a frost free ambient.
 - Always remove the cowl cover prior to operating the water heater.
 - Do not place articles on or against this appliance.
 - Do not use or store flammable materials near this appliance.
 - Do not spray aerosols in the vicinity of this appliance while it is in operation.
 - Do not modify this appliance.
- Any modifications to the unit, including accessories and cowl, or the use of spare parts and accessories that are important to the operation of the system that are not original Truma parts and failure to follow the installation and operating instructions will void the warranty and release Truma from any liability claims. It also becomes illegal to use the appliance, and in some countries this even makes it illegal to use the vehicle.
 - Any work involving connection or interconnecting wiring must be carried out by a licensed electrician. If the mains cable (supply cord) is damaged, it must be replaced by the manufacturer, its service agent or similarly qualified persons in order to avoid a hazard.
 - Before accessing terminals, please ensure all supply circuits are disconnected (i.e. 230 V \sim – 240 V \sim and 12 V \Rightarrow) and that the gas supply is securely turned off.
 - The operating pressure for the gas supply is 2.75 kPa (AUS – Propane) and must correspond to the operating pressure of the appliance (see data plate).
 - LPG systems and pressure regulators must comply with the technical and administrative regulations of the country in which the appliance is used. For your own safety it is absolutely necessary to have the complete gas installation regularly checked by an expert (at least every 2 years). The vehicle owner is always responsible for arranging the gas inspection.
 - Do not operate when travelling.
 - Do not operate the water heater when refuelling the vehicle and when it is in the garage.
 - Items sensitive to heat (e. g. spray cans) must not be stored in the installation area, since excess temperatures may occur there under certain circumstances.
 - During the initial operation of a brand new appliance (or after it has not been used for some time), a slight amount of fumes and a slight smell may be noticed for a short while.

Operating instructions

Always observe the operating instructions prior to starting! The vehicle owner is responsible for correct operation of the appliance.

! Before using the product for the first time, it is essential to flush the entire water supply through with clean warm water. Always mount the cowl cap when the water heater is not being operated! Drain the water heater if there is a risk of frost! **Warranty claims will not be accepted for frost damage.**

! Always remove the cowl cover prior to operating the water heater.

If connecting to a central water supply (rural or city connection) or when using more powerful pumps, a pressure reducer must be used which prevents pressures of greater than 400 kPa occurring in the Truma UltraRapid.

Filling the Truma UltraRapid with water

Check that the drain valve (3) and the P&T safety valve (Fig. 2a - 4) in the cold water intake are closed.

- Close drain valve (Fig. 2 - 3).
Lever in the "e" position (close).
- Test lever (Fig. 2a - 4a) of the pressure relief valve (4) must be in the "close" position.

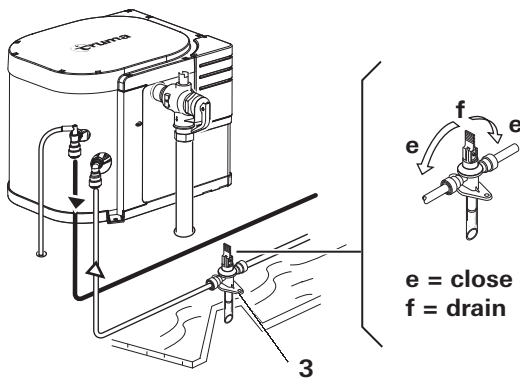

Fig. 2

- Open hot tap in bathroom or kitchen, with pre-selecting mixing taps or single-lever fittings set to "hot".
- Switch on power for water pump (main switch or pump switch).
- Leave the tap open to let air escape while the water heater is filling. The heater is filled when water flows out of the tap.

Residues of frozen water can prevent filling if there is a frost. The water heater can be defrosted by switching on the heater for a short period (max. 2 minutes). Frozen pipes can be defrosted by heating the room.

i If just the cold water system is being used, without water heater, the heater tank is also filled up with water. In order to avoid damage through frost, water must be drained by means of the drain valve, even if the heater has not been used. As an alternative, two shut-off valves, resistant to hot water, can be fitted in front of the cold and hot water connection.

Pressure and Temperature Relief Valve (P&T safety valve)

- !** Risk of scalding injury from hot water and/or tampering with the P&T safety valve!
- Do not actuate the P&T safety valve as long as the appliance is still hot.
 - Do not place a plug or reducing coupling in the discharge pipe (Fig. 2a - 4b) of the P&T safety valve.
 - Do not operate the water heater without a functioning P&T safety valve - this could cause an explosion.

The P&T safety valve (4) is a safety component and must not be removed for any reason other than replacement.

The P&T safety valve is not serviceable; if defective it must be replaced (failure to reuse an old P&T safety valve). It must be replaced by a certified service technician.

Tampering with the P&T safety valve will void the warranty.

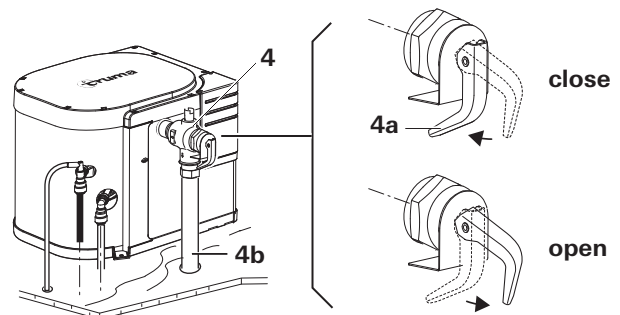

Fig. 2a

- 4 P&T safety valve
- 4a Test lever
- 4b Discharge pipe

Draining the water heater

! If the vehicle is not used during periods of frost, it is essential that the Truma UltraRapid be emptied.

- Disconnect power for water pump (main switch or pump switch).
- Allow the appliance to cool down.
- Open hot water taps in bathroom and kitchen.
- Open drain valve (Fig.2 - 3).
Lever in the "f" position (drain).

The water heater is now drained directly to the outside via the drain valve (3).

- Check that the water has been completely drained (14 litres).

Switching on gas operation



Never operate the water heater without water in it!



If the wall cowl is positioned close to an opening window (or hatch) – in particular directly under it – the window must remain closed when the water heater is in use (see warning plate).

Removing the cowl cover

- Grab the handle of the cowl cover.
- Press the palm against the lid (Fig.3a - 1) while pulling the lid off the cowl (Fig.3a - 2).

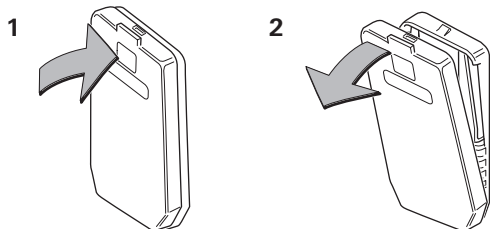

Fig. 3a

Select water heater mode

- Use the control panel to select the water heater mode.

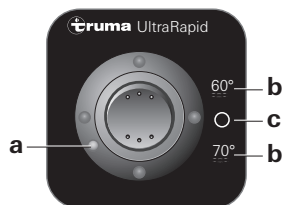

Fig. 3b

- a = Red indicator lamp "Fault"
- b = Water heater "On" 60 °C or 70 °C
- c = Water heater "Off"

If there is air in the gas supply line, it may take up to a minute before the gas is available for combustion. If the appliance switches to "Fault" during this time, switch off the appliance – wait 10 minutes – and switch on again!

When using the vehicle switches

Refer to operating instructions of the vehicle manufacturer or see switch labels.

Switching off gas operation

- Switch off the water heater to position (Fig. 3b - c).

If the water heater is not to be used for a longer period, mount cowl cover (non-observance of this point can lead to the function of the appliance being impaired through water, dirt or insects), close stop cock valve in the gas supply line and close the gas cylinder.

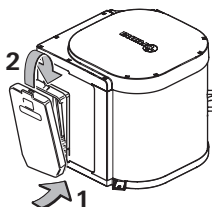

Fig. 4



Before setting off on any journey, fit cowl cap with the Truma UltraRapid switched off. Please ensure that it is secure and has locked into place (risk of accident). Defective cowl caps must not be used. **Drain the water heater if there is a risk of frost! Warranty claims will not be accepted if this is ignored.**

Red indicator lamp "Fault"

The red indicator lamp (a) lights up if there is a fault. For possible causes please refer to „Fault finding“ on page 6. To unlock, switch off the appliance, wait 10 minutes, and switch on again.

Electrical operation 230 V ~ / 240 V ~

– option –

230 V ~ / 240 V ~ 1300 W / 1415 W (5.7 A / 5.9 A)



The Truma UltraRapid must not be operated with a time switch.

Never operate the Truma UltraRapid without water in it!

- To operate the electric heating element, insert the plug into the socket and then turn it on with the switch.

The electric heating element is operational when you can see the mark (Fig. 5 - g) on the switch.

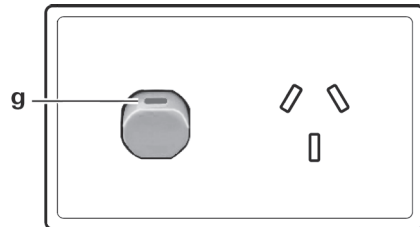

Fig. 5

i The water temperature cannot be selected, automatic temperature limitation at approx. 70 °C! For a faster heating up period the appliance can be simultaneously operated with gas and electrical power.

Maintenance



Do not modify this appliance.



Servicing should be carried out only by authorised personnel.

Only original Truma parts may be used for maintenance and repair work!

Please contact the Service Australia for service and repairs.



Materials in the device which come into contact with water are suitable for use with drinking water (see manufacturer declaration: www.truma.com – Manufacturer Declaration).

Decalcification

The Truma UltraRapid must be descaled on a regular basis (at least twice a year).

We recommend the use of suitable normal commercial products for the cleaning, disinfection and care of the Truma UltraRapid. Products containing chlorine are unsuitable.

- In order to avoid the colonization of micro-organisms, heat up the Truma UltraRapid to 70 °C at regular intervals.

- The drain valve (Fig. 2 - 3) and the P&T safety valve (Fig. 2 - 4) are to be operated regularly to remove lime deposits and to ensure that they are not blocked. Frequency: every 6 months.

Fuses

The water heater 12 V fuse is on the PCB on the water heater.

Important note

Only replace the miniature fuse on the PCB with a fuse of the same type: 1.6 A (slow action).

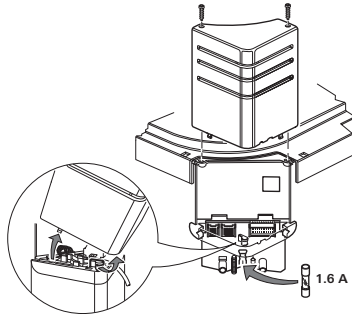

Fig. 6

i If there is a defect in the electronics, return the PCB well padded. If you fail to pack it correctly, the warranty shall no longer be valid.

Only use original Truma UltraRapid - PCB as spare parts!

Fault finding

Gas operation

Symptom

Cause

When switching on, the heater does not operate.

- No 12 V = supply voltage.

Check the power supply (operation voltage min. 10.5 V).
Check the Truma UltraRapid fuse (refer to maintenance "Fuses").

When switching on, the heater does not operate and the red lamp lights up after approx. 30 secs.

- Cowl cover fitted.
- Air in the gas supply.
- No gas supply.
- Incorrect gas pressure.

Remove cowl cover and / or clear any obstruction.
Check gas valves and gas cylinder.
To unlock (and purge air), switch off the appliance, wait 5 minutes, and switch on again.

Heater operates for a prolonged time and then the red lamp lights up.

- Excess temperature thermostat has responded.

Check water level, refill if required (close drain valve).
To unlock, switch off the appliance, wait 5 minutes, and switch on again.

Electrical operation

Symptom

Cause

When switching on, the heater does not operate.

- No 240 V ~ supply voltage.
- Excess temperature thermostat has responded.

Connect the caravan to the site supply and / or check residual current circuit breaker.
Check water level, refill if required (close drain valve).

The electrical heating element is fitted with an excess temperature cut-out. In the event of a fault, switch off at the control panel, wait 10 minutes, then switch on again.

Water supply

Symptom

Cause

Water drips from the P&T safety valve.

- Water pressure too high.
- Lime or dirt under the P&T safety valve seat.

Check water pressure (max. 400 kPa), use a pressure reducer when connected to central water supply.

Allow the appliance to cool and then slowly raise the test lever (Fig. 2a – 4a) to flush the water system and attempt to force dirt or foreign matter out of the P&T safety valve seat.

Replace P&T safety valve. This must be performed only by a certified service technician.

When opening the cold water tap, hot water comes out.

- Hot water flows back through the cold water supply.

Fit a non-return valve in the cold water supply (refer to installation instructions "Water connection").

If fault persists, please contact the Service Australia.

Technical data

Protection type / protection class

IP21 / class I

Water capacity

14 litres

Rated water pressure

400 kPa

Maximum working water pressure / temperature

P&T safety valve setting
500 kPa – 99 °C – 10 kW

Type of gas

Universal LPG

Test point pressure

2.75 kPa

Nominal heat input

5.2 MJ/h (H_s)

Nominal heat output

1.2 kW

Gas consumption

5.2 MJ/h

Injector size

0.70 mm

Heating up time from approx. 20 °C up to approx. 65 °C

(14 litres)

Gas operation: approx. 45 min.

Electrical operation: approx. 40 min.

Gas and electrical operation: approx. 28 min.

Power consumption 12 V ===

Ignition: 0.160 A

Heating up: 0.12 A

Stand-by: 0.05 A

Power consumption 230 V ~ / 240 V ~

Heating up: 5.7 A / 5.9 A, 1300 W / 1415 W

Weight (empty) 14 litres

BGA: 7.7 kg

BGA with peripheral devices: 8.6 kg

BGEA: 8.1 kg

BGEA with peripheral devices: 9.1 kg

Water pressure reducer

Flow range water: 0 – 10 litres/min.

Maximum inlet pressure: 700 kPa

Maximum outlet pressure: 200 kPa



The right to make technical modifications is reserved!

Dimensions

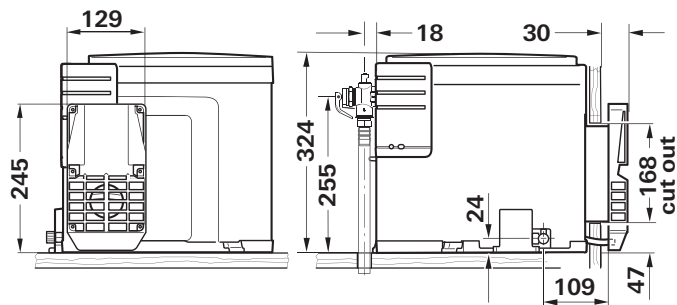

Fig. 7

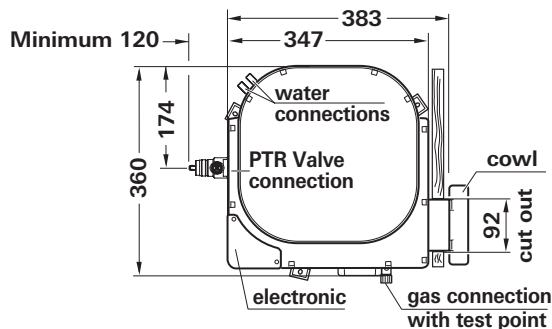

Fig. 8

(All dimensions in mm)

Truma warranty policy

The warranty is given by Service Australia for 24 months from the date of purchase against any defect arising from faulty materials or workmanship.

Repairs will be carried out during normal business hours only by Service Australia, or its duly authorised service agents, and are subject to the warranty conditions and exclusions hereunder.

Warranty conditions

- The company will only provide service on presentation of proof of purchase, on either the Truma product, or the Caravan / RV / Pleasure Craft in which the Truma product has been installed, to any authorised service agent. The purchaser must allow the service agent to photocopy the proof of purchase to facilitate his claim to the manufacturer.
- Warranty repairs can only be performed by authorised service agents and under no circumstances will Service Australia reimburse repairs carried out by unauthorised persons. Tampering with any part of the product by unauthorised personnel will automatically void the warranty.
- The product must be used solely for domestic purposes. If the product is used for commercial purposes the warranty is 6 months only.
- Where applicable, the products must be used on the appropriate electrical voltage, gas type and pressure, or fuel source.
- If at any time during the warranty period any part or parts are replaced with a part or parts not supplied or approved by Truma, this warranty shall immediately become void.

Important notice

Before calling a service technician please check carefully the operating instructions, warranty terms and conditions. If the product fails for any of the reasons detailed therein, or is faulty due to abuse, misuse or improper installation, then a service fee shall be charged to the purchaser.

If you have any queries regarding the interpretation of the warranty you should contact Service Australia.

Whilst this book represents service outlets at the time of printing, changes occur from time to time. Should you have any queries or wish to locate your nearest authorised service agent please contact Service Australia.

Warranty does not cover

Any heater which has been:

- (a) Subject to misuse, neglect, accident or alteration by any person.
- (b) Damaged or destroyed by fire, flood, act of God or other inevitable accident.
 - Fair wear and tear.
 - Damage from foreign substances such as dirt or liquid.
 - Travelling expenses or call out fee to and from authorised service agents premises.
 - Accommodation or Site Expenses.
 - Cleaning of the system or cleaning and adjustment of the gas system. This is considered to be a part of normal product maintenance.
 - Heater not operating or resultant damage to the unit because it has not been operated in a level position.
 - Freight cost of the appliance or parts, to or from, point of service or transit damage.

- Service Australia / Truma are not responsible for resultant loss or damage sustained by the purchaser.
- Appliance not operating or resultant damage to the unit where the appliance has not been installed, ventilated, flued or operated in accordance with the manufacturer's instructions.

Apart from any warranties implied by the Trade Practices Act 1974 or any relevant State legislation all other warranties express or implied whether arising by virtue of statute or otherwise are hereby excluded.

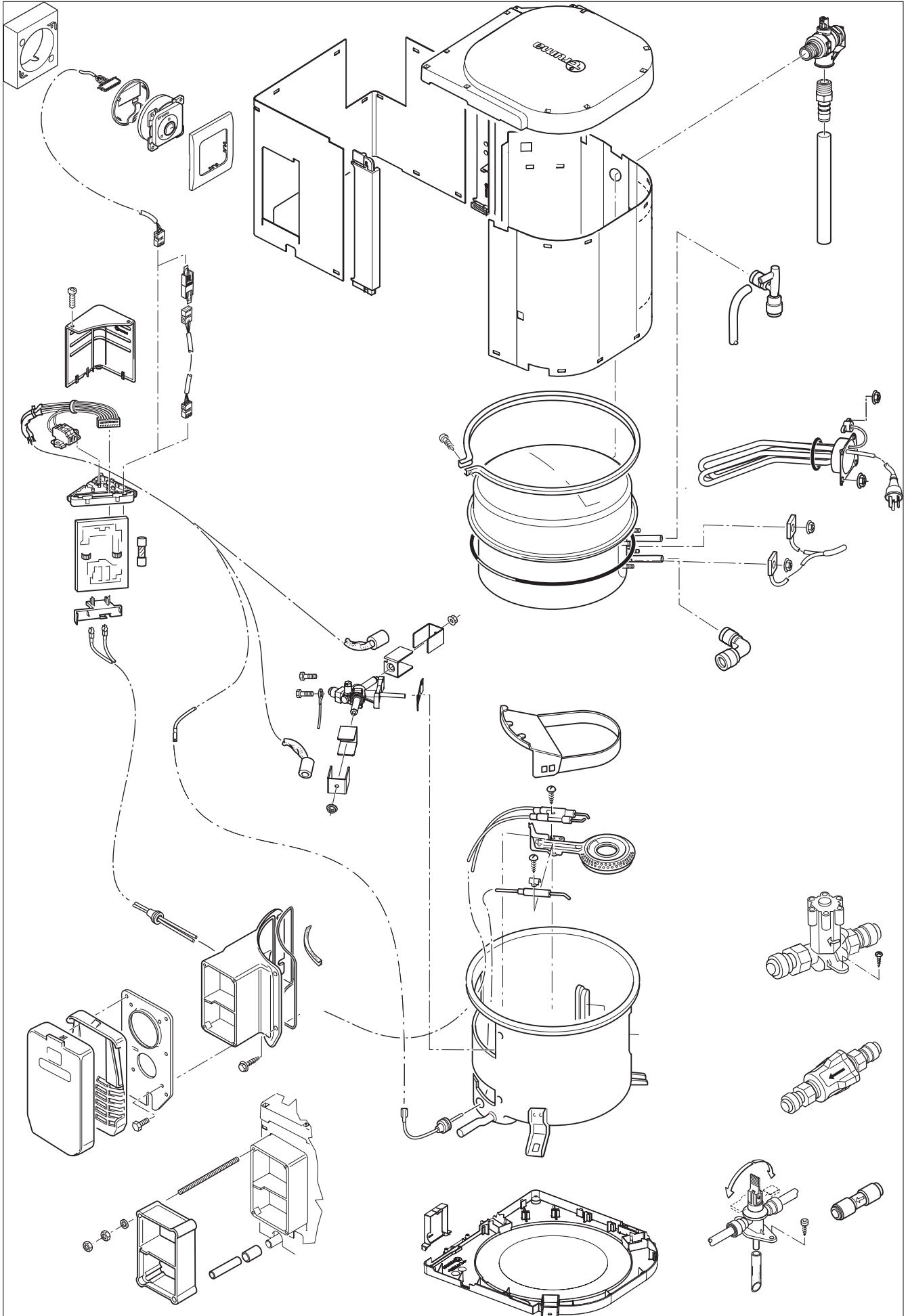

When ordering spare parts, please always state the serial number and year of manufacture.

Wiring Diagram

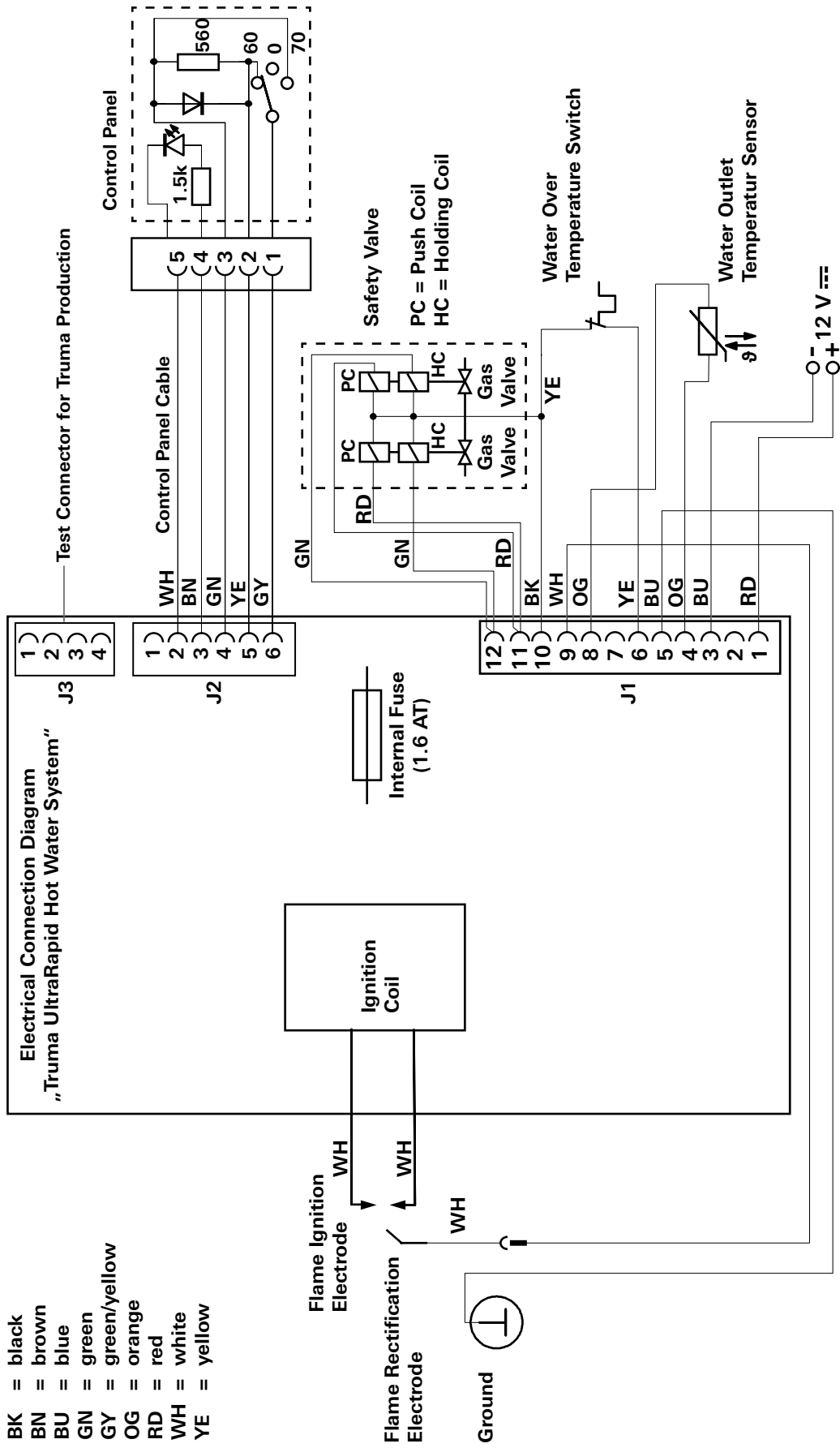

The right to make technical modifications is reserved!

In Australia, always notify the Service Australia if problems are encountered; in other countries the relevant service partners should be contacted (www.truma.com).

Having the equipment model and the serial number ready (see type plate) will speed up processing.