

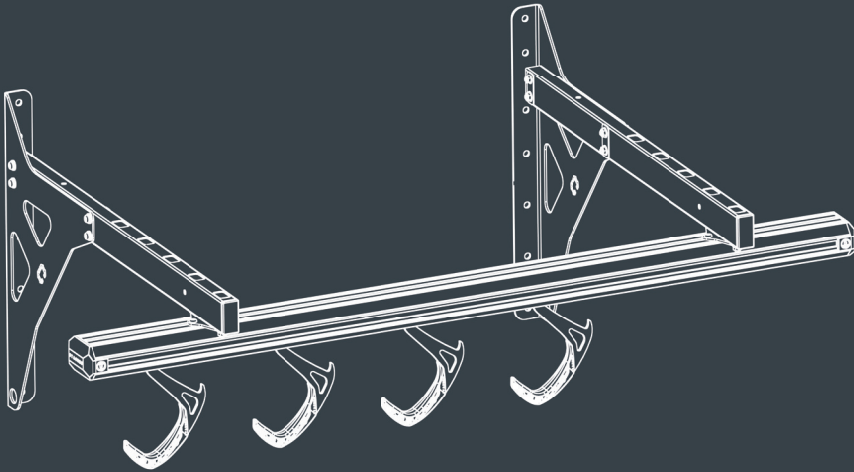

STASHED



SPACERAIL WALL KIT
SPACERAIL WALL EXTENSION KIT
INSTRUCTION MANUAL

—
VERSION .02





LIFE

Great kit helps us to live
the lifestyle we choose

STORED

We create space saving storage
and access for your kit

BETTER

Innovative, effective and well
designed storage systems



➔ STASHED

Thank you for purchasing this product.

Stashed Products was established to improve the lives of people just like you and me.

Our vision is to save you space by giving you a system to store your precious kit and keep it secure.

We believe in quality products that are built to last. Our hardware is designed, tested and manufactured in Wales. It is assembled by people who care about life balance, your kit and the environment.

Stashed has a passion for quality engineering, innovation and beautiful aesthetics.

We hope you enjoy using your product as much as we did making it.

Stashed Products Team





QUICK START

➔ 1. CHOOSE INSTALL POSITION AND MEASURE BIKES TO CHECK HEIGHT AND DISTANCE FROM OBJECTS

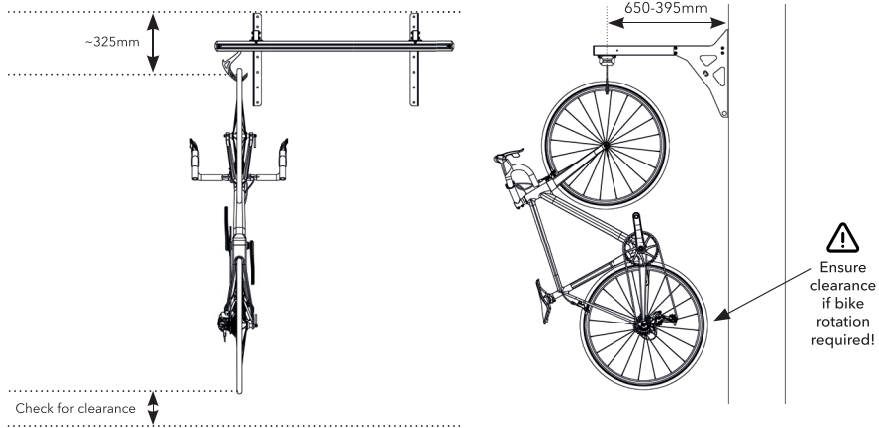

➔ 2. MEASURE POSITIONS FOR WALL BRACKET LOCATIONS ON MOUNTING STRUCTURE

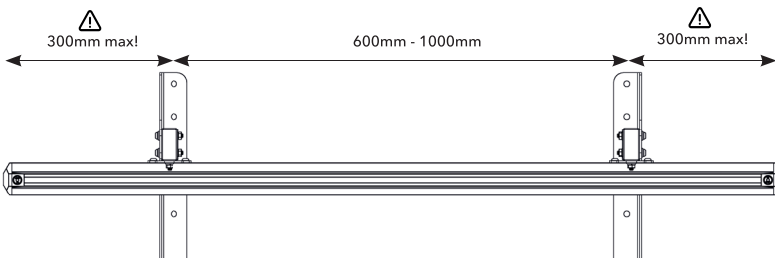

➔ 3. INSTALL WALL BRACKETS TO VERTICAL STRUCTURE

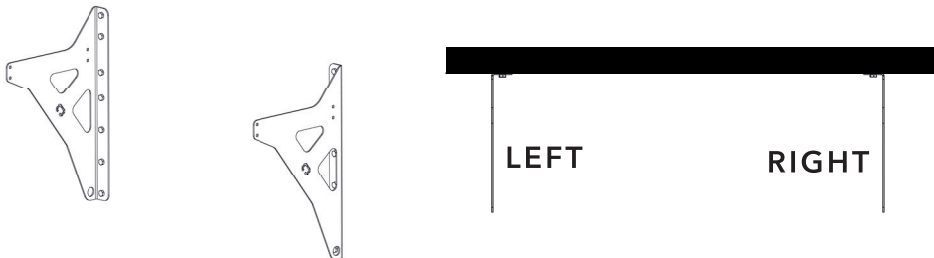



④ 4. ASSEMBLE TUBES TO WALL BRACKETS. TIGHTEN TO 5Nm

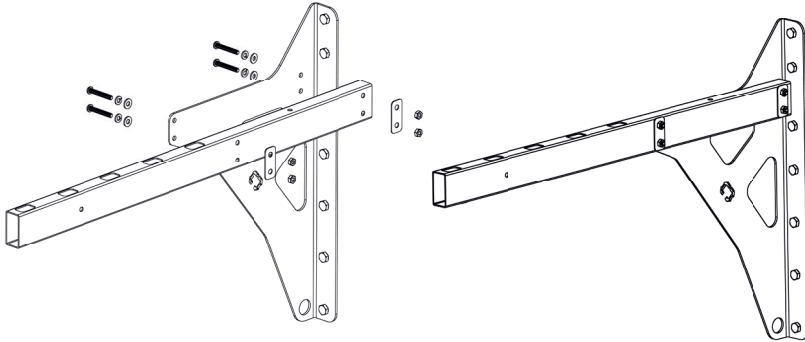

⑤ 5. ASSEMBLE END CAPS. DO NOT FULLY TIGHTEN

If applicable

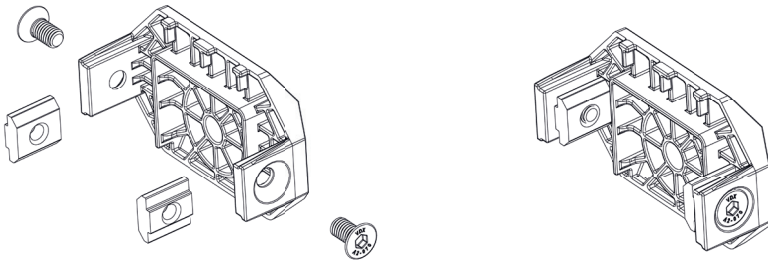

⑥ 6. ASSEMBLE JOINER. DO NOT FULLY TIGHTEN

If applicable

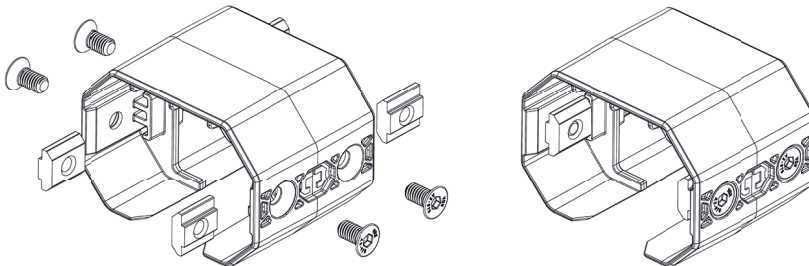



⑦ 7. ASSEMBLE TUBE PLATES TO TUBES AND TIGHTEN TO 5Nm

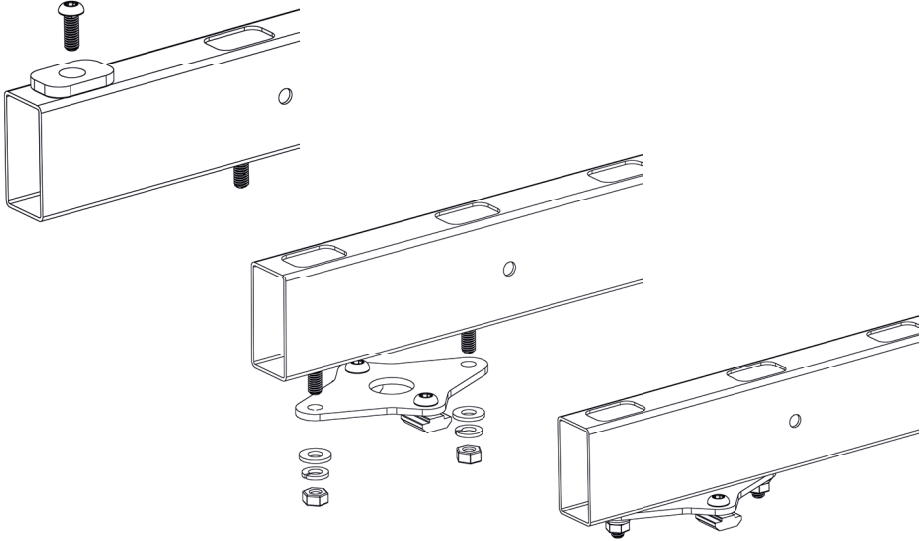

⑧ 8. INSTALL RAIL TO TUBE PLATES. TIGHTEN TO 5Nm

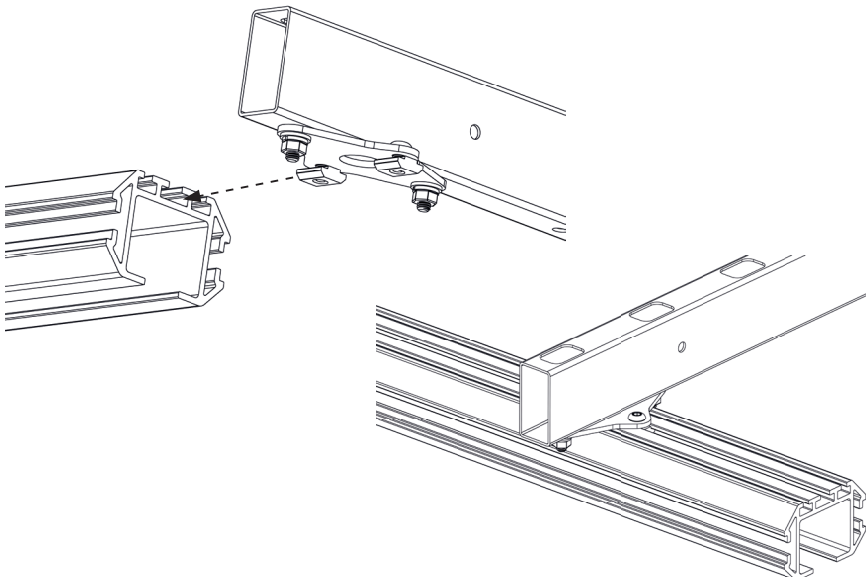



⑨ 9. INSTALL JOINER AND HANG SUPPLEMENTARY RAIL KITS FOLLOWING THE SAME PROCESS AS FIRST

If applicable

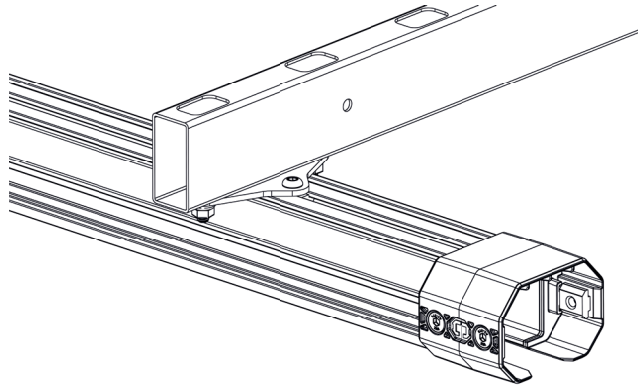

⑩ 10. INSTALL MARKING PLATE AND INSERT TROLLEYS (REFER TO P15 OF SPACERAIL HOOK INSTRUCTIONS). INSERT END CAPS AND TUBE PLUGS.

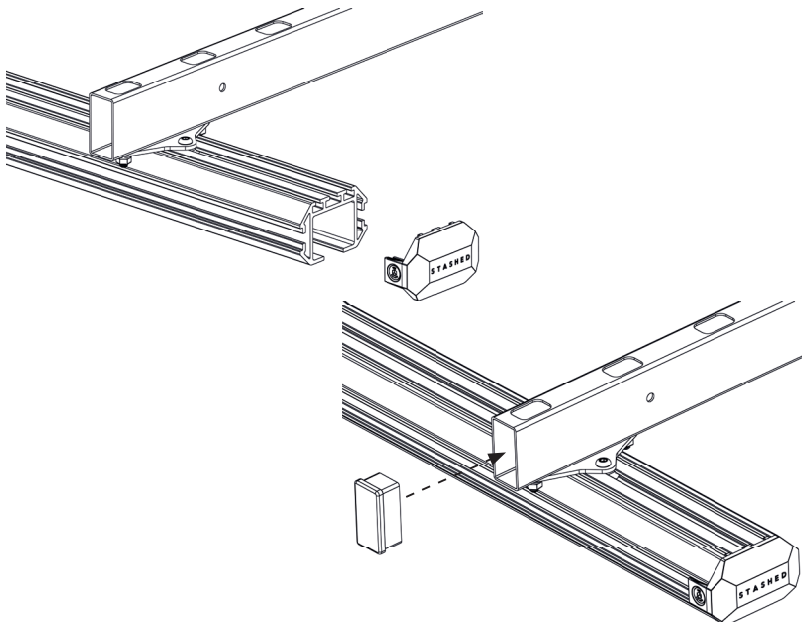



CONTENTS

Stashed Products	1
Quick Start	2
General Notes	7
Technical Specification	8
Warnings	9
Parts Identification	10
Tools and Fasteners Required	12
System Layout Recommendations	13
⌕ Fundamentals	13
⌕ Mounting height	14
⌕ Shelf board mounting	14
⌕ Wall bracket orientation	15
⌕ Suggested mounting locations	16
Locate Position and Mark Bracket Location	18
Attach Wall Bracket to Wall	18
Assemble Tubes to Wall Brackets	19
Assemble End Caps	20
Assemble Joiner	21
Assemble Tube Plate to T-Nuts	22
Assemble Tube Plate Assembly to Tubes	22
Slide Rail To Position and Attach	23
Install Marking Plate	23
Install Extension Rail Kit	24
Insert End Caps	25
Insert Tube Plugs	25
FAQ	26
Warranty>Returns	26
Maintenance	27
Notes	28



GENERAL NOTES

These instructions are for mounting the SpaceRail Wall Kit and SpaceRail Wall Extension Kit to a vertical surface, such as a wall or a structure made by you. Please refer to your other products for their own instructions.

⚠ WARNING: THIS KIT IS NOT SUITABLE FOR INSTALLATION SOLELY INTO PLASTER BOARD OR A NON-LOAD BEARING STRUCTURE. IT MUST BE SECURELY ATTACHED TO A ROBUST STRUCTURE SUITABLE OF SUPPORTING THE LOAD!

Appropriate DIY experience is required to install this system correctly, if in doubt get a professional to help.

Take time to fit your SpaceRail Wall Kit correctly. A poorly fitted SpaceRail will stop the system running correctly and reduce the performance, possibly leading to it not holding the loads stated and reducing your enjoyment using it.

Each SpaceRail Kit is suitable for up to 4 bikes, but an unlimited number of additional SpaceRail Extension Kits can be added to increase bike storage capacity. Depending on the type and size of the bikes to be stored, the addition of a SpaceRail Extension Kit may be required to ensure suitable access.

If you are unsure on how to fit or use this product, please reach out and ask our experts or look for fitting examples and instruction videos on our website www.stashedproducts.co.uk



TECHNICAL SPECIFICATION

-  ATTACHES DIRECTLY TO A VERTICAL STRUCTURE SUCH AS BRICK, SOLID BLOCKS, METAL, CONCRETE OR TIMBER THAT IS CAPABLE OF SUPPORTING THE LOAD. IT IS YOUR RESPONSIBILITY TO ENSURE THE STRUCTURE IS OF SUITABLE LOAD BEARING CAPABILITY.
- Due to the varying range of wall materials, fasteners are not included and should be specified by the installer based on the wall material.
- The system is infinitely extendible depending on how many bikes are to be stored and is only limited by the mounting structure.
- All fasteners are stainless steel, so will not rust and will look new for years to come. The wall brackets, although powder coated, are not intended for external use.
- Component materials: Stainless Steel, Mild Steel, Acetal, Nylon, 6063 T6 Aluminium.
- The wall brackets can be used as a shelf with the addition of a board fitted by the user, but the maximum load per rail/wall bracket pair should still be observed when placing items on the shelf.

NUMBER OF BIKES	NUMBER OF RAILS	TOTAL LENGTH (OUTSIDE OF END CAPS)	MAX LOAD/ INDIVIDUAL RAIL (KG)	MAX TOTAL LOAD PER SYSTEM (KG)
2	1	1,196mm	100kg	100kg
3	1	1,196mm	100kg	100kg
4*	1/2	1,196mm/2,392mm	100kg	100kg/200kg
5	2	2,392mm	100kg	200kg
6	2	2,392mm	100kg	200kg
7	2	2,392mm	100kg	200kg
8*	2/3	2,392mm/3,588mm	100kg	200kg/300kg
9	3	3,588mm	100kg	300kg
10	3	3,588mm	100kg	300kg
11	3	3,588mm	100kg	300kg
12	3	3,588mm	100kg	300kg

* When 4 or 8 bikes are to be stored it is possible a SpaceRail Wall Extension Kit is required to allow enough space for bike rotation and access. For example, it is suggested that 4 x road bikes would be acceptable on a single SpaceRail Kit, but 4 x mountain bikes with wide handle bars can compromise access and may require an extension kit for the full benefits.



SpaceRail Wall Kit



SpaceRail Wall Kit with SpaceRail Wall Extension Kit

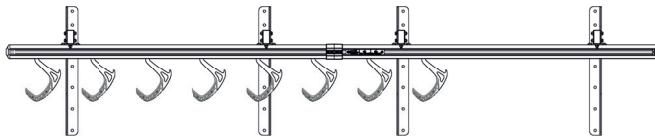

WARNINGS

⚠ STASHED PRODUCTS DOES NOT TAKE RESPONSIBILITY FOR THE STRUCTURE THAT THE PRODUCT IS INSTALLED TO. IN USING THIS PRODUCT, THE CUSTOMER AGREES TO TAKE ALL NECESSARY MEASURES TO ENSURE THE STRUCTURE IS SUITABLE.

- Although every effort has been taken to remove sharp edges, the end of the rail can still be sharp, so take care when handling or installing this product.
- Objects can fall from the SpaceRail system if not correctly hung.
- Do not suspend a secondary rail solely from the first rail without support, even momentarily during installation.
- Ensure End Caps are secured correctly. If they are not there is a chance of Bike Hooks falling from the SpaceRail.
- Do not bump the End Caps with the Bike Hook during bike movement. It is not intended to absorb heavy impacts.
- The SpaceRail Kit is not suitable for shock loads. Gently place objects on to the Bike Hook.
- Not to be used by children or as a toy!
- When installing this product and using power tools always wear the appropriate safety equipment.
- Check bike is safe for use and all hanging adapters have been removed every time it is taken off the SpaceRail.
- **⚠ NEVER USE FOR HUMAN SUSPENSION!**
- **⚠ WARNING: CANCER AND REPRODUCTIVE HARM.**
SEE WWW.P65WARNINGS.CA.GOV



PARTS IDENTIFICATION

Depending on your order you could have either or both of the following products.



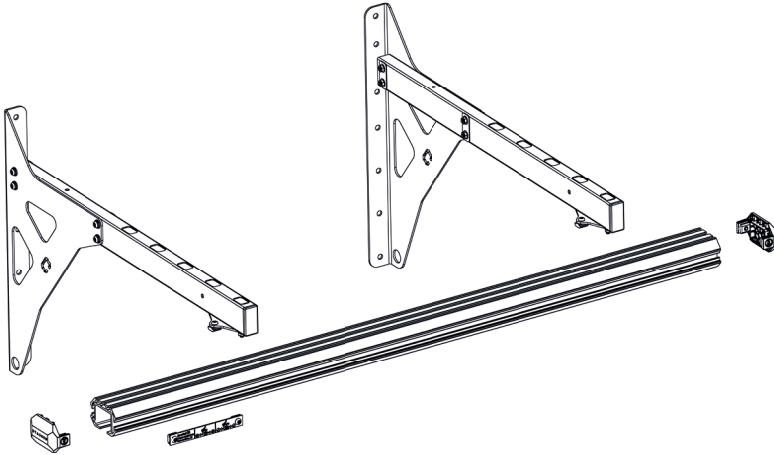



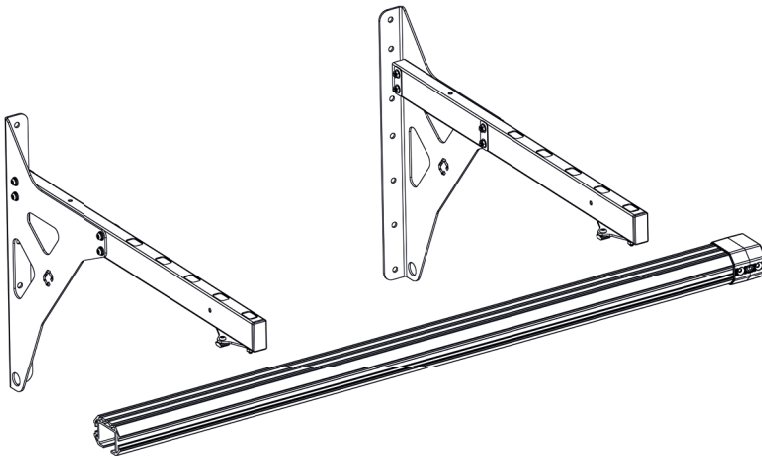





➔ **SPACERAIL WALL KIT: SB-SA-0035**



➔ **SPACERAIL WALL EXTENSION KIT: SB-SA-0036**









PART	IMAGE	SYSTEM	
		SpaceRail Wall Kit SB-SA-0035	SpaceRail Wall Extension Kit SB-SA-0036
Rail		1	1
Wall Bracket - Left		1	1
Wall Bracket - Right		1	1
Wall Tube		2	2
Tube Plate		2	2
End Cap		2	n/a
Rail Joiner		n/a	1
T Nut		10	8
M6 x 12mm Countersunk Bolt		4	4
M6 x 40mm Button Head Bolt		8	8
M6 x 10mm Button Head Bolt		6	4
Marking Plate		1	n/a
M6 x 16mm Button Head Bolt		4	4
M6 Washer		12	12

Continued on the next page....



PART	IMAGE	SYSTEM	
		SpaceRail Wall Kit SB-SA-0035	SpaceRail Wall Extension Kit SB-SA-0036
M6 Spring Washer		12	12
M6 Nut		12	12
Double Washer		4	4
End Cap		2	2
Bolt Inserter		1	0

TOOLS AND FASTENERS REQUIRED

Wall fasteners are NOT included with your kit due to the varying array of wall materials. Therefore you need to decide which fasteners are required for your installation. If you are unsure please consult a person with suitable DIY or building experience.

As part of our sustainability policy we do not supply low-quality single use tools with our products. We anticipate you will already have the majority of the tools you need to install this product, but if you don't then you can buy tools from our website.

- 4mm hex key
- 10mm Spanner or Socket
- Spirit Level
- Marker Pen
- Tape Measure
- No.2 Pozi screwdriver
- Electric Drill
- Driver bit for chosen wall fasteners
- Impact Driver *
- A helper*
- Stud Finder*

* Not essential, but makes the installation easier and safer.



SYSTEM LAYOUT RECOMMENDATIONS

③ FUNDAMENTALS

Your SpaceRail Kit is adaptable to many different situations, but a few fundamental mounting rules should be followed:

-  BE AWARE OF WATER AND GAS PIPES AND ELECTRICITY CABLES. ALWAYS TAKE ADVICE FROM A PROFESSIONAL IF YOU'RE UNSURE.
- Each Rail must be suspended from at least two Wall Brackets, each with multiple wall fasteners. Additional Wall Brackets can be used to add extra support and share the load further.
- Locate mounting points that are structurally suitable so that the kit can be installed so the rail is flat and parallel. Check with a spirit level.
- Wall Brackets are adjustable on the rail and should be located 600mm-1000mm apart to fit with your mounting structure. Most buildings have studs at a 400mm, 500mm or 600mm spacing. If your wall is boarded and structural mountings are not visible, then we suggest using a Stud Finder tool as it is essential you locate the supporting structure correctly.

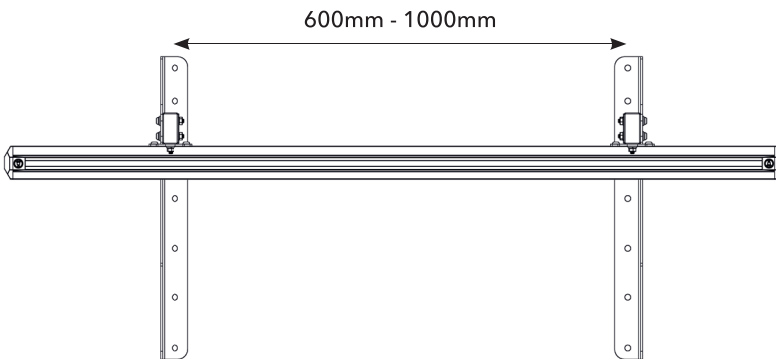

- The maximum cantilever length from the centre of the Wall Brackets to the end of the Rail is 300mm.

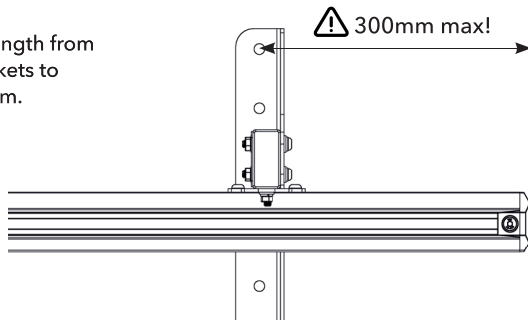



➔ MOUNTING HEIGHT

→ Ensure you have enough height to hang your bikes with the wheels off the floor. The Rail and Trolley requires roughly 325mm of height allowance from the top of the wall bracket to the inside of the bikes front wheel rim.

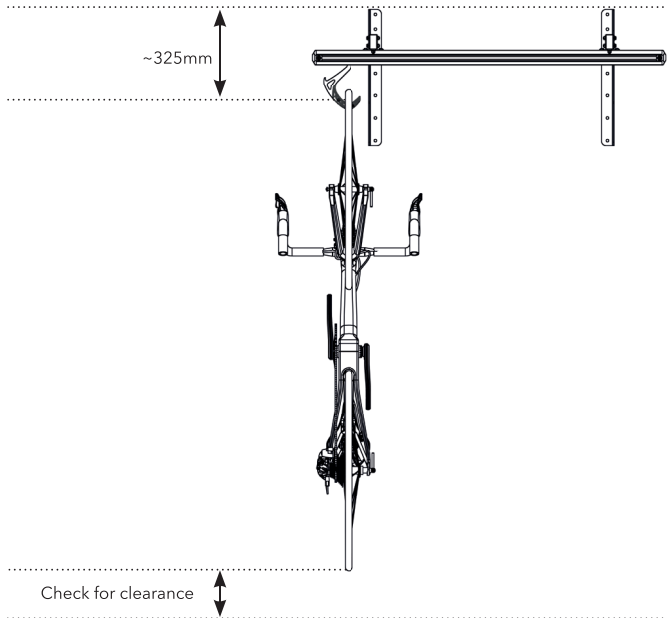

➔ SHELF BOARD MOUNTING

→ A shelf board (not included) can be added to the wall brackets so the space above can be used for storage. The overall load limit per rail should still be observed i.e. 100kg per rail including the bikes, shelf and contents spread across the rail length. Screw holes are provided in the tubes for attaching a shelf board.

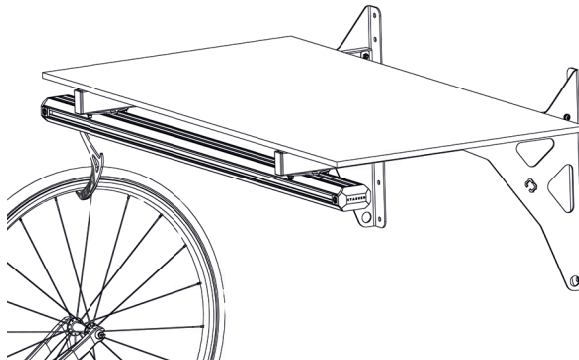



② WALL BRACKET ORIENTATION

- The Wall Brackets can be used in either orientation.
- A combination of orientations can be used if it helps improve installation strength.

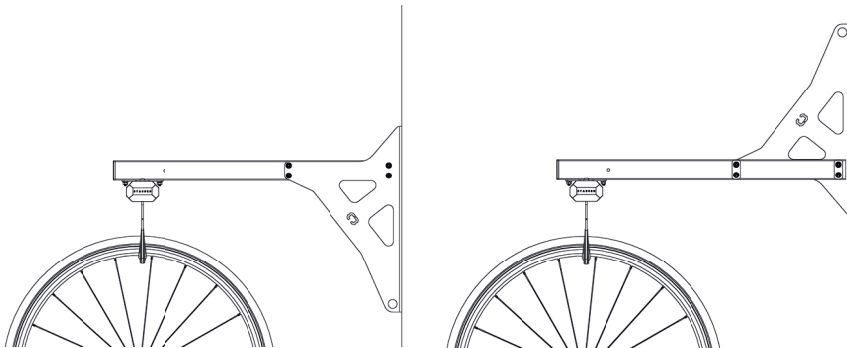

- Always spread the load across the Rail length with the heaviest bikes spread out and not clustered at one end or all in one area. This will help to share the loads across multiple wall brackets.

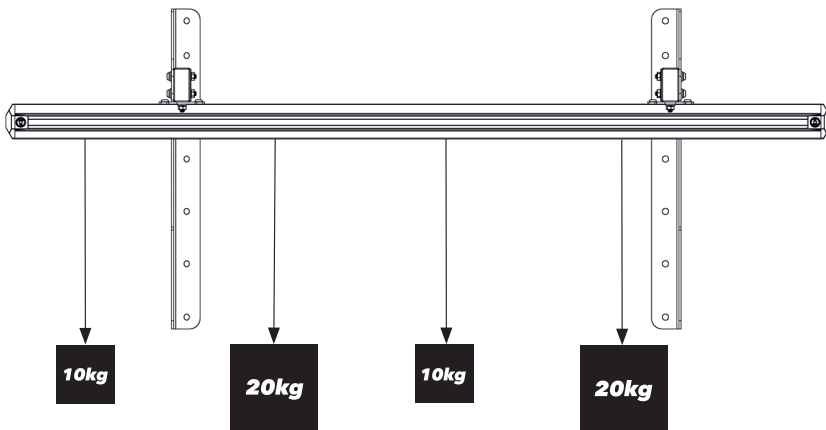



➔ SUGGESTED MOUNTING LOCATIONS

OPEN ENDED AND FREE SPACE

- The SpaceRail Kit can be mounted parallel with a wall with both ends of the system accessible, or can be in complete free space.

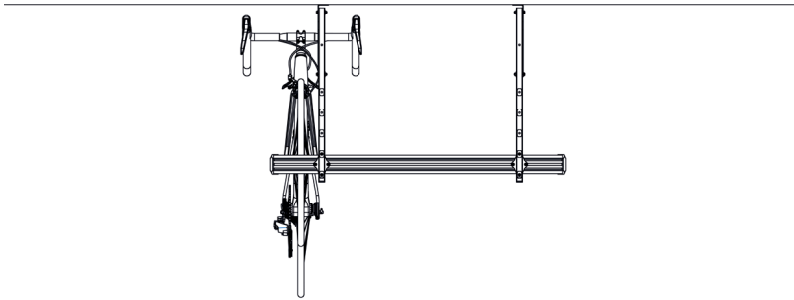

CORNER

- To mount in a corner you need to ensure the end bikes handlebar is in clearance to the end wall.
- Measure the end bikes outside of handlebar to stem centre distance. With this dimension in mind, mount the SpaceRail away from the end wall to maximise Rail usable length.

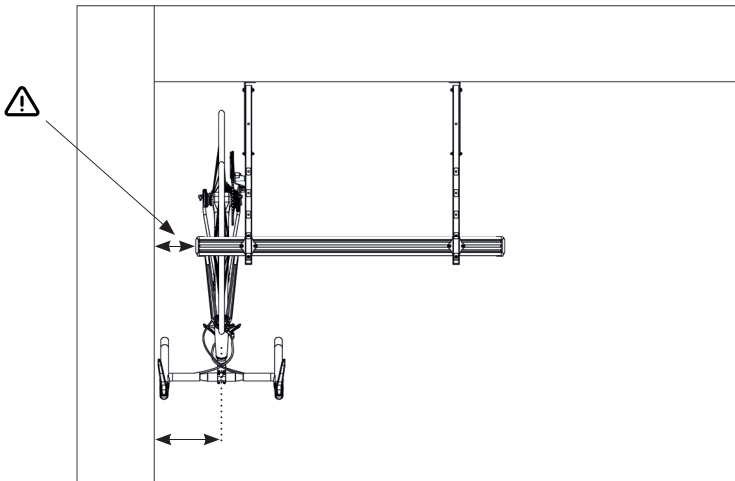



MOUNTING PARALLEL TO A WALL

- The distance to mount your SpaceRail Kit away from any parallel wall is dependent on the size of your bikes and if rotation is required once hung.
- Look for the largest bike you are planning on storing and measure the length and depth to ensure it spins freely once hung. For bikes with wide handlebars this dimension might also need to be taken in to account.
- To allow bikes to slide and spin freely the bikes should not rest against the wall once hung up, although this is possible providing hooks are not angled in the rail and scraping the sides.
- As a general rule, the Rails default mounting position is at the furthest setting out at 650mm from any walls to ensure bikes can spin and slide freely, but the mounting position is adjustable to three other fixed positions - 565mm, 480mm and 395mm. These positions will limit the ability to spin bikes once hung up.

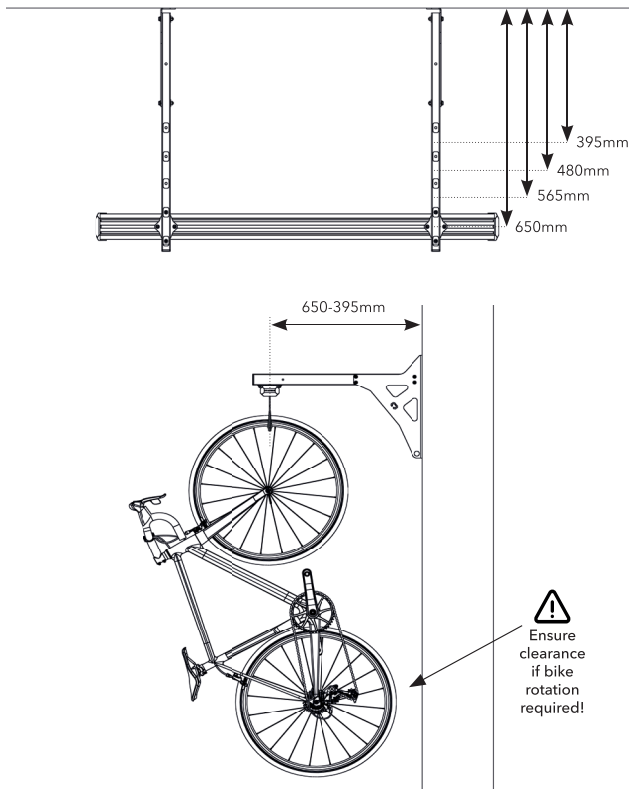



INSTALLATION

➔ LOCATE POSITION AND MARK BRACKET LOCATIONS

⚠ THE WALL BRACKET KIT MUST BE SCREWED TO A ROBUST STRUCTURE AND NOT SOLELY IN TO PLASTERBOARD OR NON-STRUCTURAL MATERIALS!

- Ensure the points where the Wall Brackets are to be mounted are flat, of solid structure and parallel. If not then the Rail could be mounted at an angle, misaligned or twisted and will not function correctly.
- If you are installing more than one Rail, then measure the distance between mounting points to ensure the structure available is suitable at each Wall Bracket location.

➔ ATTACH WALL BRACKETS TO WALL

- Attach wall brackets to wall using appropriate fasteners.
- If you are installing more than one Rail, then mount all brackets and check they are level and vertical with a spirit level.
- Use as many bracket fixing points as needed to spread the load across the mounting surface. It is also a good idea to spread the load with supplementary wall battens or boards across the wall.

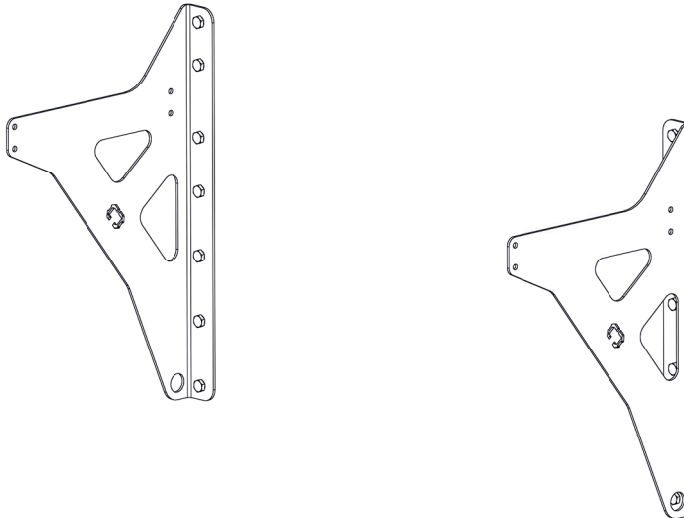



④ ASSEMBLE TUBES TO WALL BRACKETS

- Place the M6 x 40mm Bolts through the M6 Spring Washer and M6 Washer. Place through the holes in the Wall Brackets and attach Tube.
- Add Double Washers and thread on the M6 Nuts. Tighten equally to 5Nm. Do not crush side of Tube by over tightening.
- Repeat for all Wall Brackets.

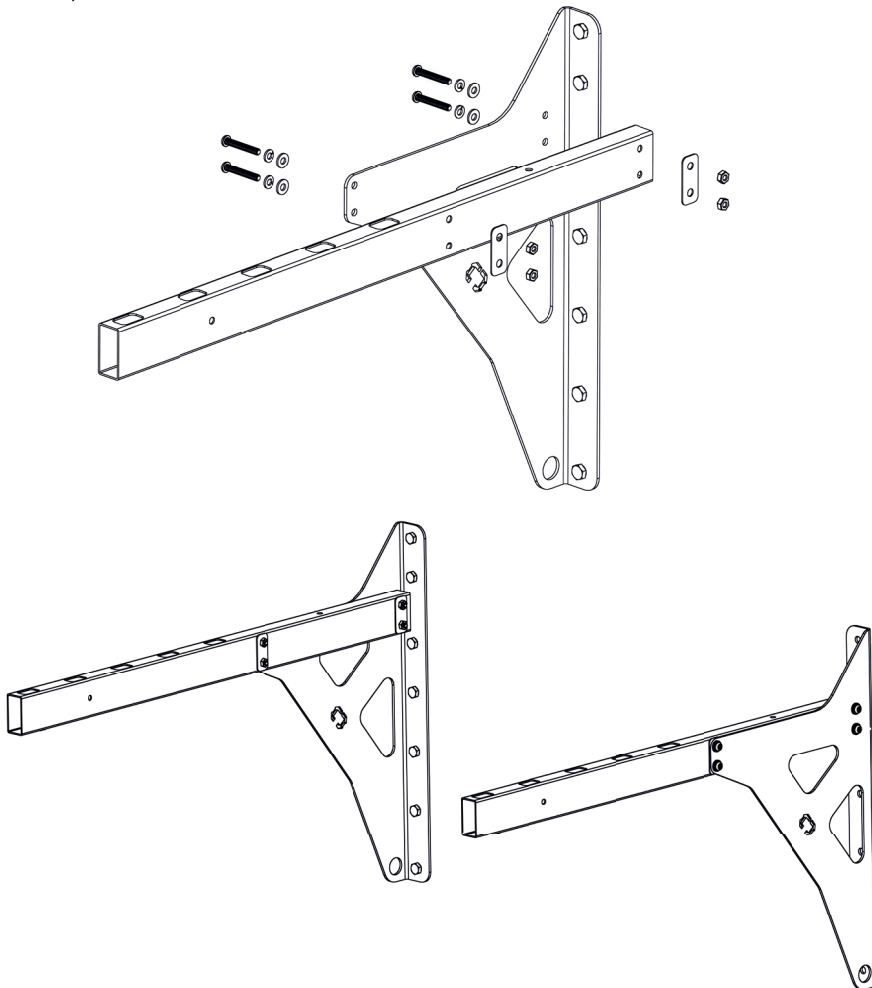



⊕ ASSEMBLE END CAPS

If applicable

- Place the M6 x 12mm Bolts through the countersunk holes in the sides of the End Cap and loosely screw to T-Nuts. Do not tighten fully.

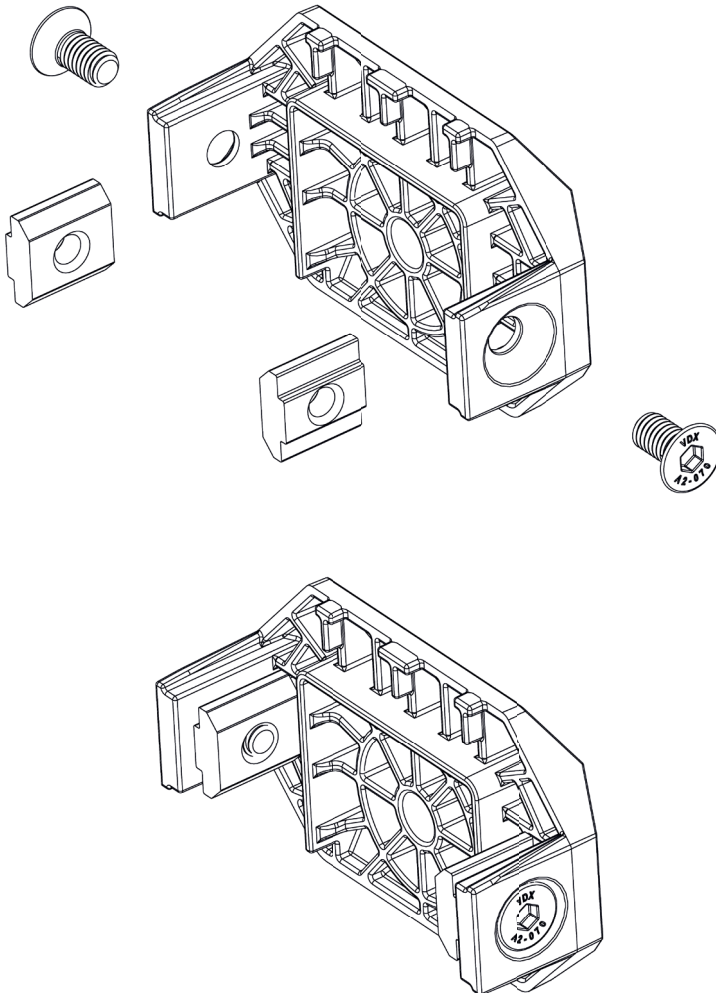



⊕ ASSEMBLE JOINER

If applicable

- Place the M6 x 12mm Bolts through the countersunk holes in the sides of the Joiner and loosely screw to T-nuts. Do not tighten fully.

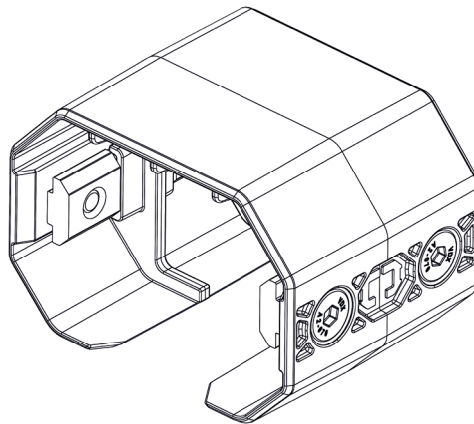
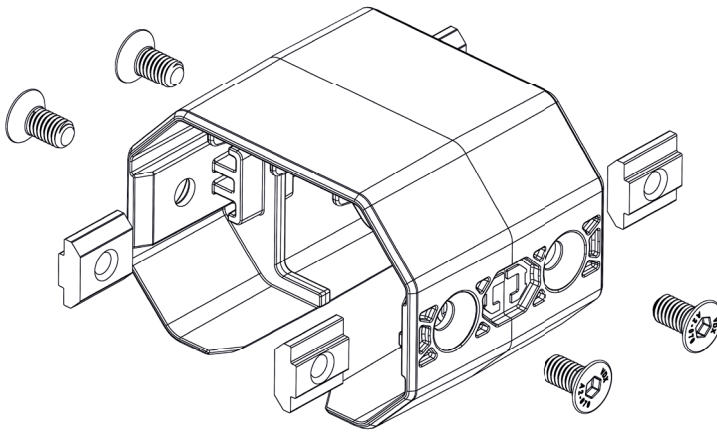



③ ASSEMBLE TUBE PLATE TO T-NUTS

→ Place M6 x 10mm Bolts through Tube Plate holes and thread on M6 T-Nuts. Do not fully tighten.

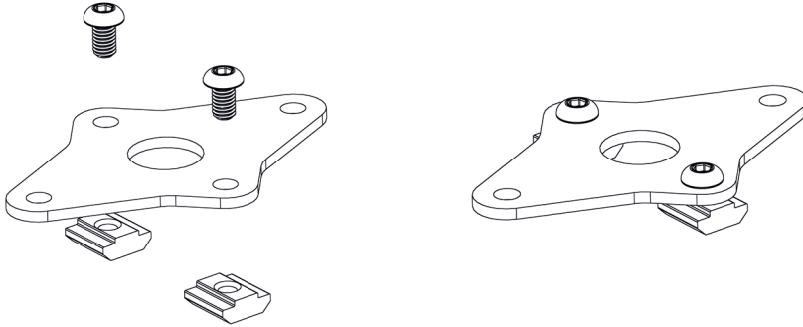

③ ASSEMBLE TUBE PLATE ASSEMBLIES TO TUBES

→ Place M6 x 16mm bolts through Tubes using Bolt Inserter. Remove Bolt Inserter. Place Tube Plate Assembly through bolts and secure using M6 Washer, M6 Spring Washer and M6 Nut. Repeat for all Tubes and tighten to 5Nm.

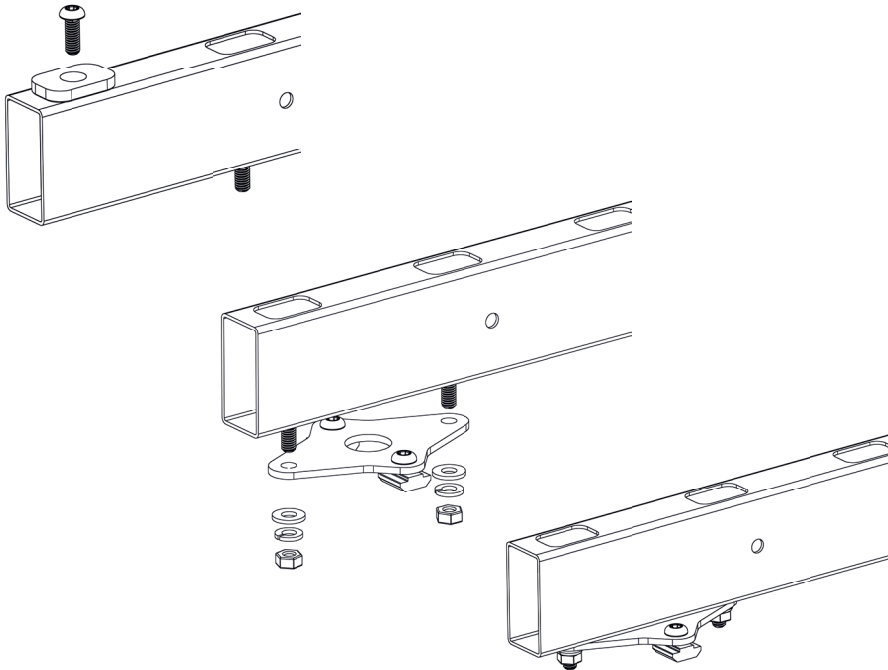



③ SLIDE RAIL TO POSITION AND ATTACH

- Slide Rail into position by aligning T-Nuts into track in top of Rail on both brackets.
- Tighten all Nuts and Bolts to 5Nm once Rail is positioned correctly and square to Wall Brackets with no skewing.

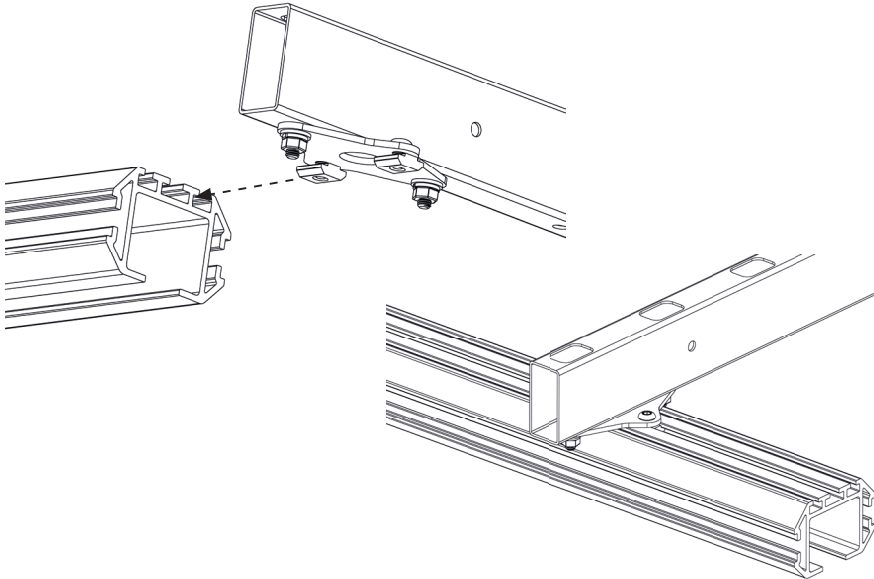

Note: Ensure Rail is level, parallel with any surrounding objects and not bent, twisted or distorted from the installation process. Check using a spirit level and adjust as necessary.

④ INSTALL MARKING PLATE

- Place M6 x 10mm Bolt through Marking Plate and loosely thread in to T-Nuts. Slide assembly in to side of Rail and tighten Bolts to 2.5Nm.

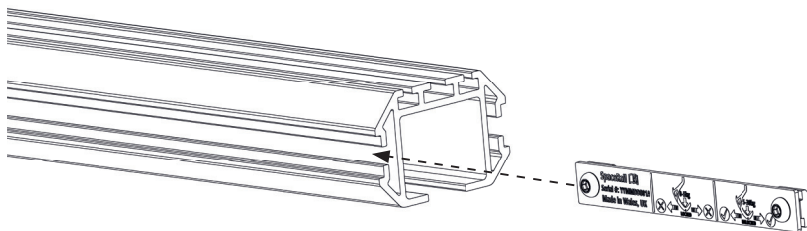



➔ INSTALL EXTENSION RAIL KIT

If applicable

- Before fitting the second Rail to the mounting structure, attach the Rail Joiner to the Rail and loosely tighten the M6 x 12mm Bolts to hold it in place.

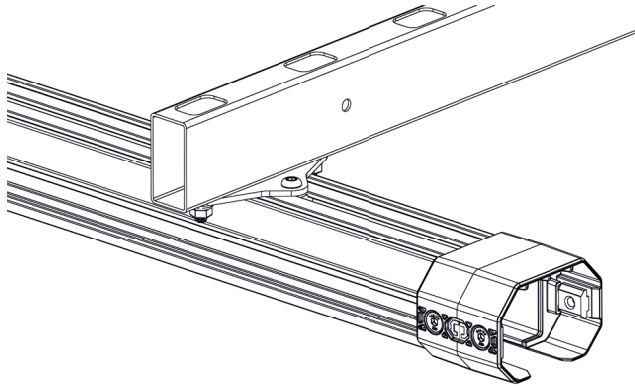

- Install second Rail as per the first by sliding T-Nuts in to Rail slot.
- Fit the second Rail to the first Rail - keep well supported. Do not rely on the Joiner component alone to support the second Rail!
- Ensure both Rails are parallel and aligned concentrically. Tighten the second Rail to the Tube Plates and equally tighten bolts in Joiner to 2.5Nm.

⚠ WARNING: DO NOT MOUNT WITH CENTRE OF JOIN MORE THAN 300MM FROM THE CENTRE OF A WALL BRACKET. IF YOU CANNOT ACHIEVE THIS THEN EXTRA WALL BRACKETS MAY BE REQUIRED!

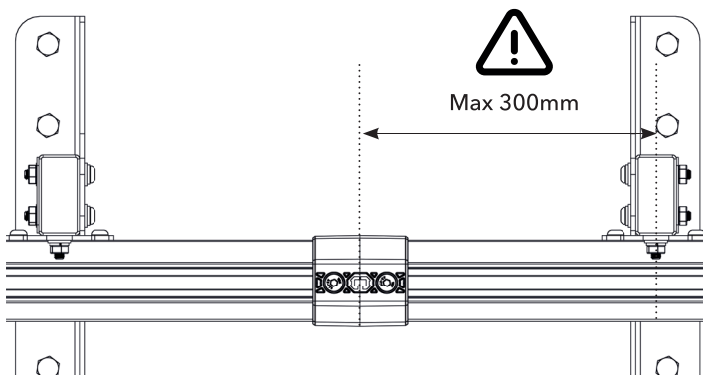



➔ INSERT END CAPS

→ Align T-nuts to Rail and slide End Cap into Rail and tighten Bolts equally with a 4mm Hex Key to 2.5Nm.

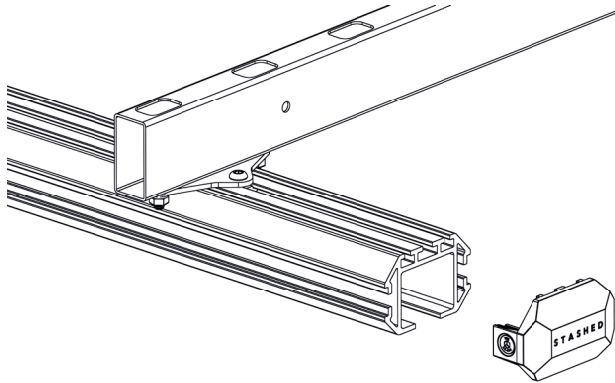

→ Insert Trolleys in to Rail (see separate instructions) and ensure they run freely and smooth the whole length of the Rail. Repeat process for second End cap.

➔ INSERT TUBE PLUGS

→ Push Tube Plug in to end of Tubes.

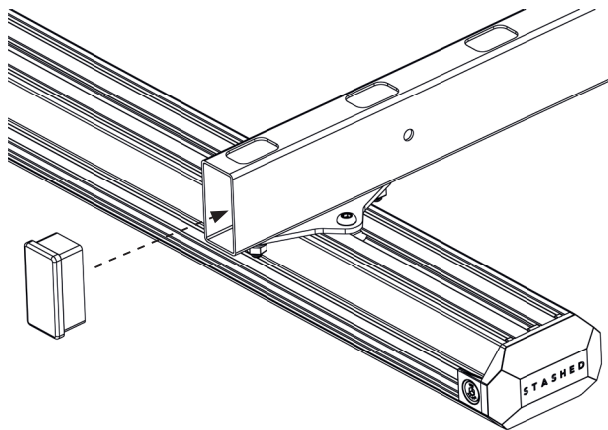



FAQ

My Bike Hook keeps rolling on its own

- Check the level of your Rail. Adjust Wall Brackets if necessary.

Can I shorten the Rail?

- Yes! You can cut the Rail to any length you require, but be sure to de-bur the ends well with a small file. We recommend using a power chop saw with blade suitable for aluminium. Do not attempt this with a hack saw.

My Trolley gets stuck in the joint

- Rails are not positioned or aligned correctly. Remove all bikes, adjust Rails and refit.

I cannot spin my bikes or access them easily

- Change bike order to improve access.
- Rail length is not long enough so add additional SpaceRail Extension Kit.

How many Rails can I join?

- The number of Rails that can be joined together is unlimited and is only constrained by the support structure. Consult a structural engineer to determine the maximum load the structure can support.

Can I recycle Stashed Products packaging at home?

- Yes! Absolutely! All our packaging is biodegradable in normal home composting or can be recycled in household recycling collections.

WARRANTY/RETURNS

All hardware are covered by a 2-year no quibble warranty.
Please see our website for full details.

If any issues arise outside of the warranty period, then we have designed our products to be easily serviceable to ensure they have a long life in service. All parts are available separately from our website.

If you have problems with your product or questions, please contact us for support.



MAINTENANCE

Your Rail Kit is generally very low maintenance and should give years of trouble free use. Some basic maintenance tips:

- Ensure the Rail is kept clean and free from debris, this is especially important on the faces where the Bike Hook wheels run.
- Clean your Rail with a soft cloth or use compressed air to remove debris from hard to reach areas.

PERIODIC CHECKS

- Structural integrity of the mounting area.
- Tightness of all bolts and screws.
- Wear to any components such as wheels or impact areas.
- Ensuring free movement of trolleys when loaded.
- Ensuring mechanisms function correctly when unloaded.



NOTES



NOTES



STASHED

LIFE STORED BETTER

MADE IN WALES by STASHED PRODUCTS

Unit 1, Y-Glyn, Llanberis, Caernarfon, Gwynedd, LL55 4EL, UK

www.stashedproducts.co.uk
sales@stashedproducts.co.uk

+44 (0) 3301 334 836

—

Got a great install? Share it at

@STASHEDPRODUCTS

