

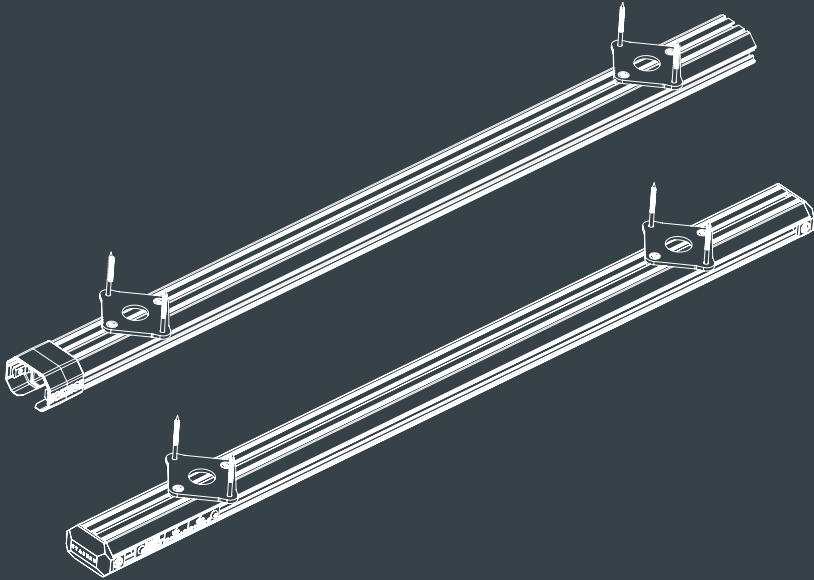

STASHED



SPACERAIL KIT
SPACERAIL EXTENSION KIT
INSTRUCTION MANUAL

—
VERSION .03





LIFE

Great kit helps us to live
the lifestyle we choose

STORED

We create space saving storage
and access for your kit

BETTER

Innovative, effective and well
designed storage systems



➔ STASHED

Thank you for purchasing this product.

Stashed Products was established to improve the lives of people just like you and me.

Our vision is to save you space by giving you a system to store your precious kit and keep it secure.

We believe in quality products that are built to last. Our hardware is designed, tested and manufactured in Wales. It is assembled by people who care about life balance, your kit and the environment.

Stashed has a passion for quality engineering, innovation and beautiful aesthetics.

We hope you enjoy using your product as much as we did making it.

Stashed Products Team





QUICK START

➔ 1. CHOOSE INSTALL POSITION AND MEASURE BIKES TO CHECK HEIGHT AND DISTANCE FROM OBJECTS

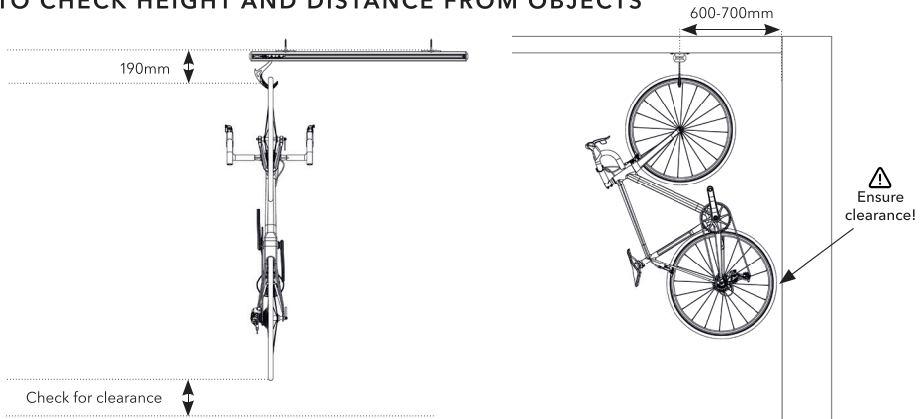

➔ 2. MEASURE POSITIONS FOR CEILING PLATE LOCATION ON MOUNTING STRUCTURE

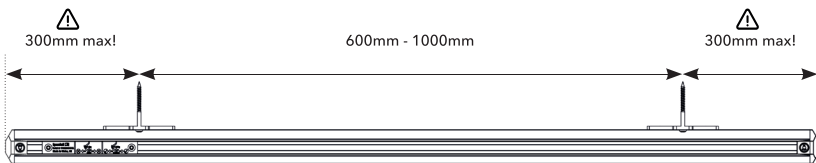

➔ 3. MARK INDICATION ON RAIL FOR CEILING PLATE LOCATIONS

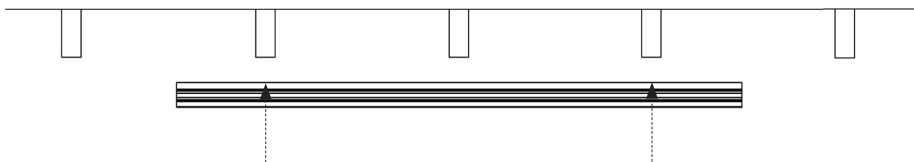



④ 4. ASSEMBLE CEILING PLATES



④ 5. ASSEMBLE END CAPS

If applicable

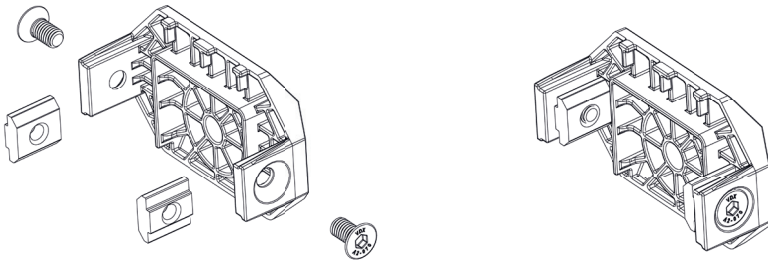

④ 6. ASSEMBLE JOINER

If applicable

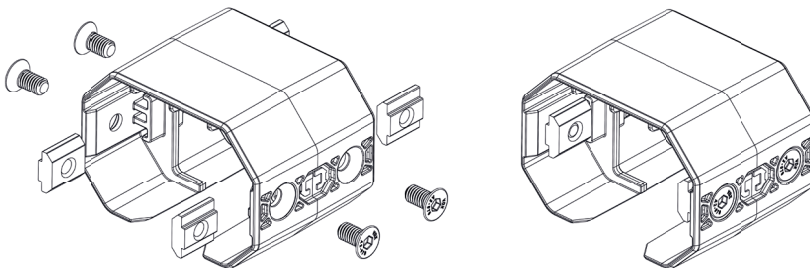



⑦ 7. ASSEMBLE CEILING PLATES TO INDICATION MARKS ON RAIL AND TIGHTEN TO 7Nm

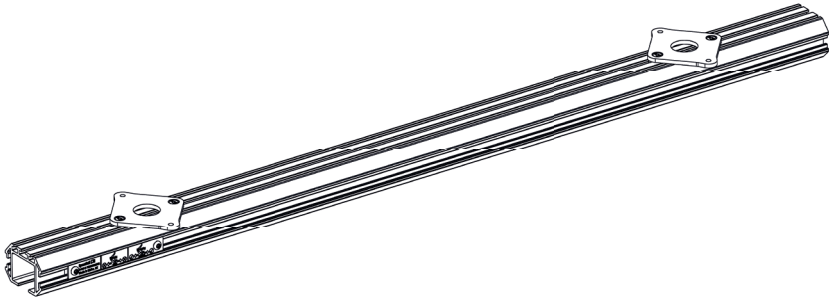

⑧ 8. INSTALL RAIL TO CEILING STRUCTURE

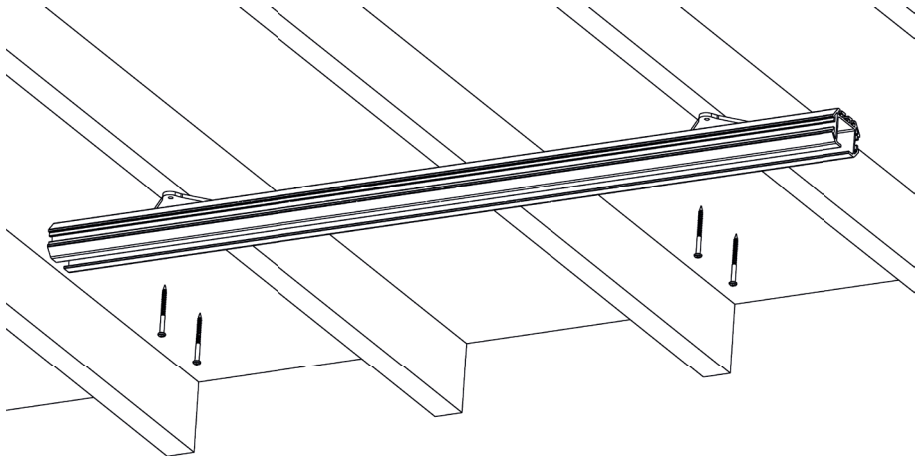



⊖ 9. INSTALL JOINER AND HANG SUPPLEMENTARY RAILS FOLLOWING THE SAME PROCESS

If applicable

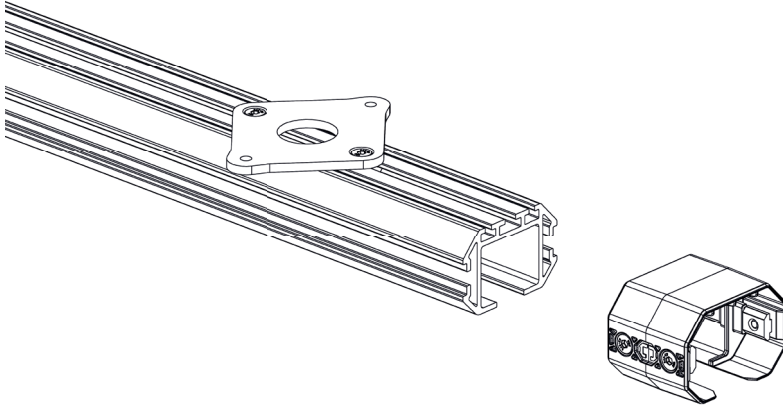

⊖ 10. INSERT TROLLEYS (REFER TO P15 SPACERAIL HOOK INSTRUCTIONS) AND ATTACH END CAPS

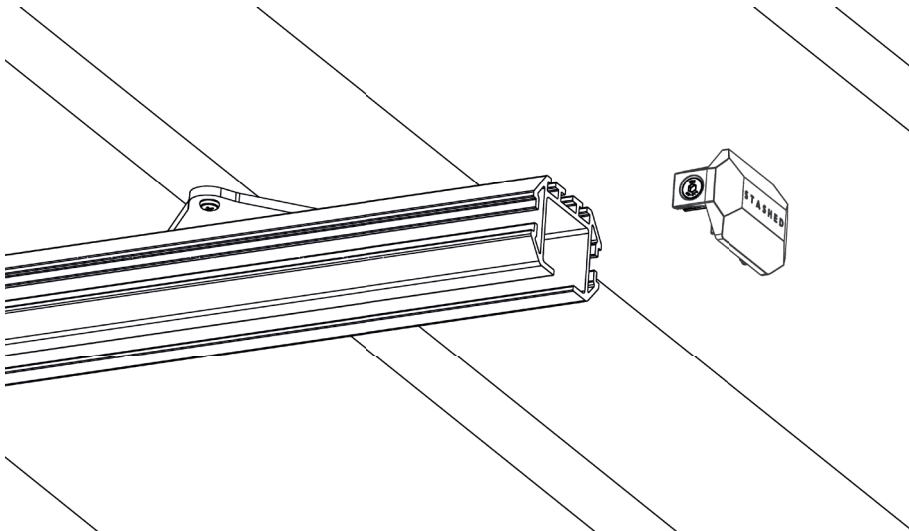



CONTENTS

Stashed Products	1
Quick Start	2
General Notes	7
Technical Specification	8
Warnings	9
Parts Identification	10
Tools Required	12
Bike Layout and Mark for Installation	13
⊖ Fundamentals	13
⊖ Mounting across beams	14
⊖ Mounting along beams	15
⊖ Distance from objects	16
⊖ Suggested Mounting Positions	17
⊖ Locate position and mark rail	18
Assemble Ceiling Plates	19
Assemble End Caps	20
Assemble Joiner	21
Slide Ceiling Plates to Required Positions	22
Install Marking Plate	23
Hold Rail to ceiling and attach	23
Install Extension Kit	24
Insert End Caps	25
FAQ	26
Warranty>Returns	26
Maintenance	27
Notes	28



GENERAL NOTES

These instructions are for ceiling mounting the SpaceRail Kit and SpaceRail Extension Kit to a wooden structure, such as ceiling joists, beams, rafters or a structure made by you. Please refer to your other products for their own instructions.

⚠ WARNING: THIS KIT IS NOT SUITABLE FOR INSTALLATION SOLELY INTO PLASTER BOARD. IT MUST BE SECURELY ATTACHED TO A ROBUST STRUCTURE SUITABLE TO SUPPORT THE LOAD!

Appropriate DIY experience is required to install this system correctly, if in doubt get a professional to help.

Take time to fit your SpaceRail Kit correctly. A poorly fitted SpaceRail will stop the Trolley running correctly and reduce the performance of the system, possibly leading to it not holding the loads stated and reducing your enjoyment using it.

Each SpaceRail Kit is suitable for up to 4 bikes, but an unlimited number of additional SpaceRail Extension Kits can be added to increase storage capacity. Depending on the type and size of the bikes to be stored, the addition of a SpaceRail Extension Kit may be required to ensure suitable access.

If you are unsure on how to fit or use this product, please reach out and ask our experts or look for fitting examples and instruction videos on our website www.stashedproducts.co.uk



TECHNICAL SPECIFICATION

-  ATTACHES DIRECTLY TO CEILING JOISTS, RAFTERS, BEAMS OR OTHER SUITABLE STRUCTURES CAPABLE OF SUPPORTING THE LOAD. IT IS YOUR RESPONSIBILITY TO ENSURE THE STRUCTURE IS OF SUITABLE LOAD BEARING CAPABILITY.
- The system is infinitely extendible depending on how many bikes are to be stored and is only limited by the mounting structure.
- The rail is suitable for mounting internally or externally. All fasteners are stainless steel, so will not rust and will look new for years to come.
- Component materials: Stainless Steel, Acetal, Nylon, 6063 T6 Aluminium.
- The suggested bikes per rail and max loads are shown in the table below:

NUMBER OF BIKES	NUMBER OF RAILS	TOTAL LENGTH (OUTSIDE OF END CAPS)	MAX LOAD/ INDIVIDUAL RAIL (KG)	MAX TOTAL LOAD PER SYSTEM (KG)
2	1	1,196mm	120kg	120kg
3	1	1,196mm	120kg	120kg
4*	1/2	1,196mm/2,392mm	120kg	120kg/240kg
5	2	2,392mm	120kg	240kg
6	2	2,392mm	120kg	240kg
7	2	2,392mm	120kg	240kg
8*	2/3	2,392mm/3,588mm	120kg	240kg/360kg
9	3	3,588mm	120kg	360kg
10	3	3,588mm	120kg	360kg
11	3	3,588mm	120kg	360kg
12	3	3,588mm	120kg	360kg

* When 4 or 8 bikes are to be stored it is possible a SpaceRail Extension Kit is required to allow enough space for bike movement and access. For example, it is suggested that 4 x road bikes would be acceptable on a single SpaceRail Kit, but 4 x mountain bikes with wide handle bars can compromise access and may require an extension kit.



SpaceRail Kit

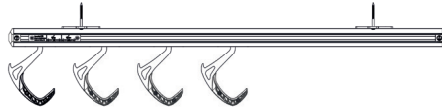

SpaceRail Kit with SpaceRail Extension Kit

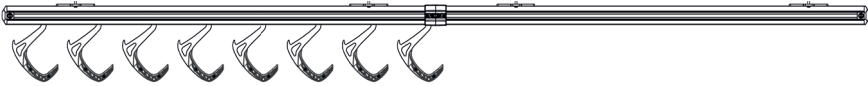

WARNINGS

⚠ STASHED PRODUCTS DOES NOT TAKE RESPONSIBILITY FOR THE STRUCTURE THAT THE PRODUCT IS INSTALLED TO. IN USING THIS PRODUCT, THE CUSTOMER AGREES TO TAKE ALL NECESSARY MEASURES TO ENSURE THE STRUCTURE IS SUITABLE.

- Although every effort has been taken to remove sharp edges, the end of the rail can still be sharp, so take care when handling or installing this product.
- Objects can fall from the SpaceRail system if not correctly hung.
- Do not suspend a secondary rail from the first rail without ceiling support, even momentarily during installation.
- Ensure End Caps are secured correctly. If they are not there is a chance of Bike Hooks falling from the SpaceRail.
- Do not bump the End Caps with the Bike Hook during bike movement. It is not intended to absorb heavy impacts.
- The SpaceRail Kit is not suitable for shock loads. Gently place objects on to the Bike Hook.
- Not to be used by children or as a toy!
- When installing this product and using power tools always wear the appropriate safety equipment.
- Check bike is safe for use and all hanging adapters have been removed every time it is taken off the SpaceRail.
- **⚠ NEVER USE FOR HUMAN SUSPENSION!**
- **⚠ WARNING: CANCER AND REPRODUCTIVE HARM. SEE WWW.P65WARNINGS.CA.GOV**



PARTS IDENTIFICATION

Depending on your order you could have either or both of the following products.



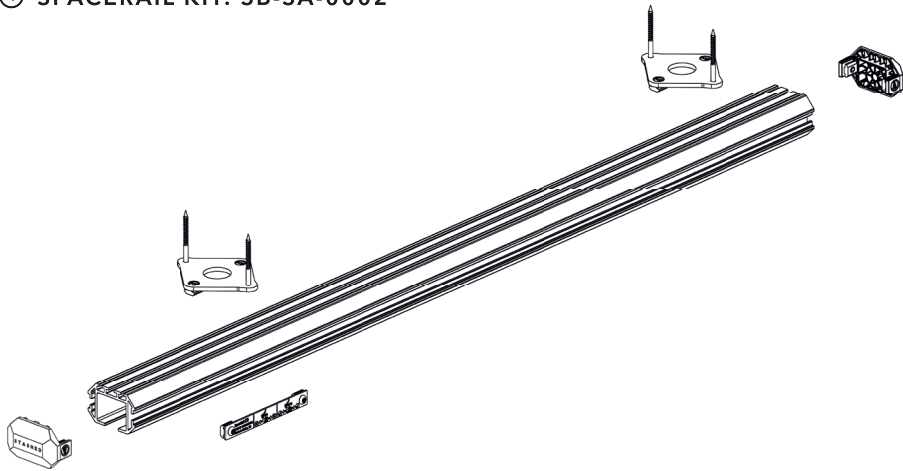

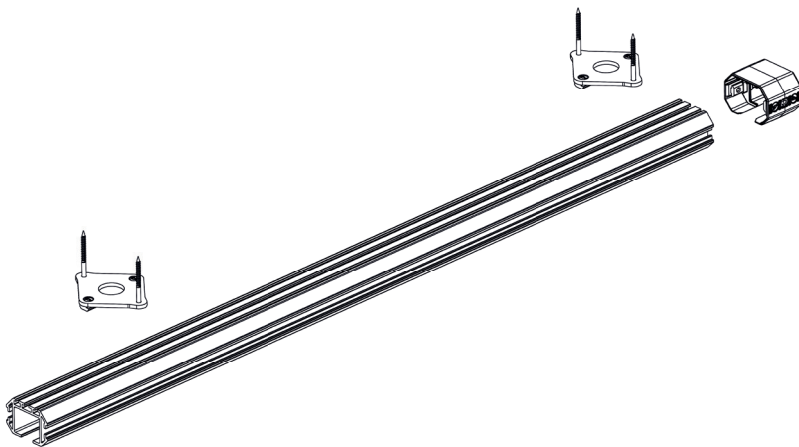

→ SPACERAIL KIT: SB-SA-0002

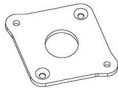
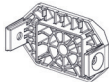
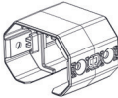

→ SPACERAIL EXTENSION KIT: SB-SA-0003





PART	IMAGE	SYSTEM	
		SpaceRail Kit SB-SA-0002	Space Rail Extension Kit SB-SA-0003
Rail		1	1
Ceiling Plate		2	2
End Cap		2	n/a
Rail Joiner		n/a	1
T Nut		10	8
M6 x 12mm Countersunk Bolt		8	8
No10 (4.8mm) x 60mm Wood Screw		4	4
M6 x 10mm Button Head Bolt		2	n/a
Marking Plate		1	n/a



TOOLS REQUIRED

As part of our sustainability policy we do not supply low-quality single use tools with our products. We anticipate you will already have the majority of the tools you need to install this product, but if you don't then you can buy tools from our website.

- 4mm hex key
- Spirit Level
- Marker Pen
- Tape Measure
- No.2 Pozi screwdriver
- Electric Drill
- Impact Driver
- 3mm Drill Bit
- T20 Torq Bit
- A helper*
- Stud Finder*

* Not essential, but makes the installation easier and safer.



BIKE LAYOUT AND MARK FOR INSTALLATION

➔ FUNDAMENTALS

Your SpaceRail Kit is adaptable to many different situations, but a few fundamental mounting rules should be followed:

-  **BE AWARE OF WATER AND GAS PIPES AND ELECTRICITY CABLES. ALWAYS CHECK WITH A PROFESSIONAL IF YOU'RE UNSURE.**
- Each Rail must be suspended from at least two Ceiling Plates, each with two Screws. Additional Ceiling Plates can be used to add extra support and share the load.
- Locate mounting points that are structurally suitable so that the kit can be installed to a flat parallel surface. Check with a spirit level. If you have an angled ceiling, then please see our website for other mounting solutions.
- The supplied Screws require at least 50mm of thread engagement to a solid timber structure to achieve full strength. If you have a non-timber mounting structure then you will need to provide your own fasteners.
- Ceiling Plates are adjustable and should be located 600mm-1000mm apart to fit your mounting structure. Most buildings have beams or joists at a 400mm, 500mm or 600mm spacing. If your ceiling is boarded then we suggest using a Stud Finder tool as it is essential you locate the supporting structure correctly.

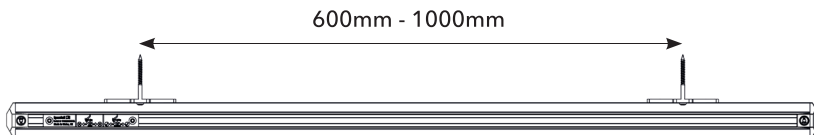

- The maximum cantilever length from the centre of the Ceiling Plate to the end of the Rail is 300mm.

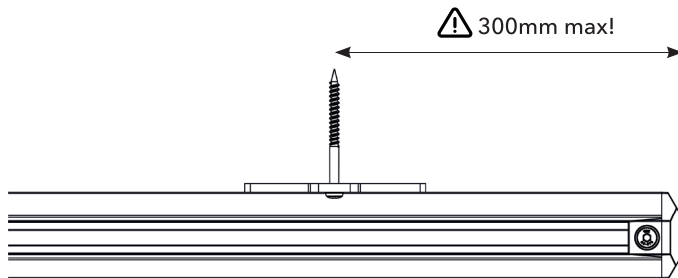



⌚ MOUNTING HEIGHT

- Ensure you have enough height to hang your bikes with the wheels off the floor. The Rail and Trolley requires 190mm of height allowance from the ceiling to the inside of the bikes wheel rim.

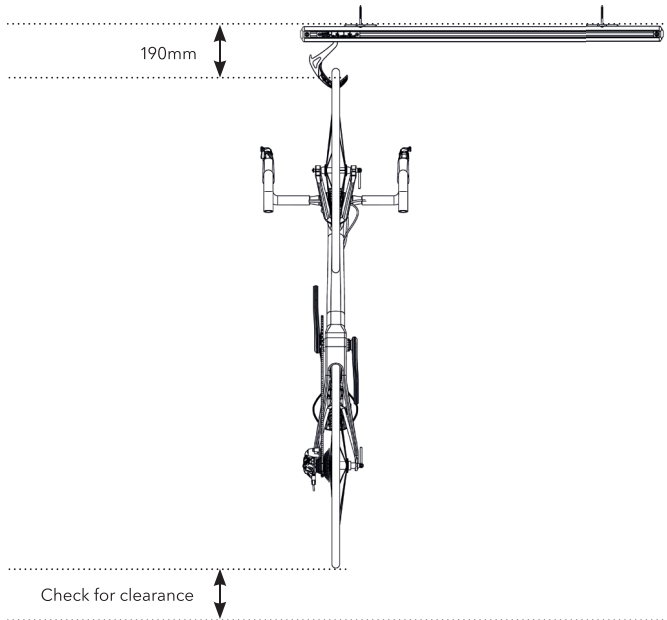

⌚ MOUNTING ACROSS BEAMS

- In an ideal scenario each Rail should be mounted across at least two independent load bearing beams to spread the weight of the system.

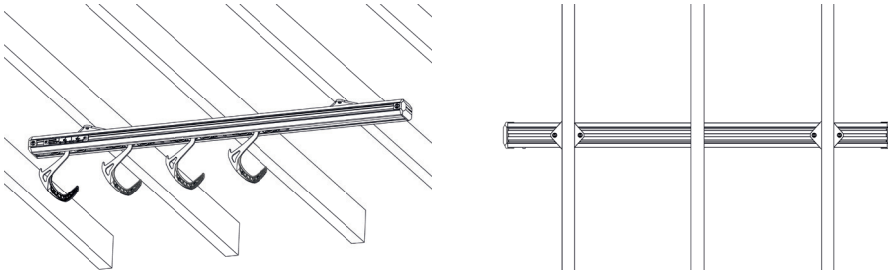



➔ MOUNTING ALONG BEAMS

→ If mounting parallel with structural beams or joists, then the loads need to be shared across more than one beam or joist. A supplementary beam spanning component is required; see our website for details.

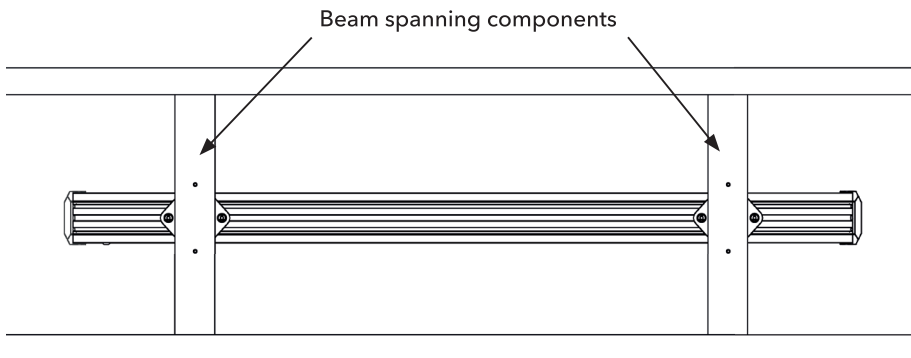
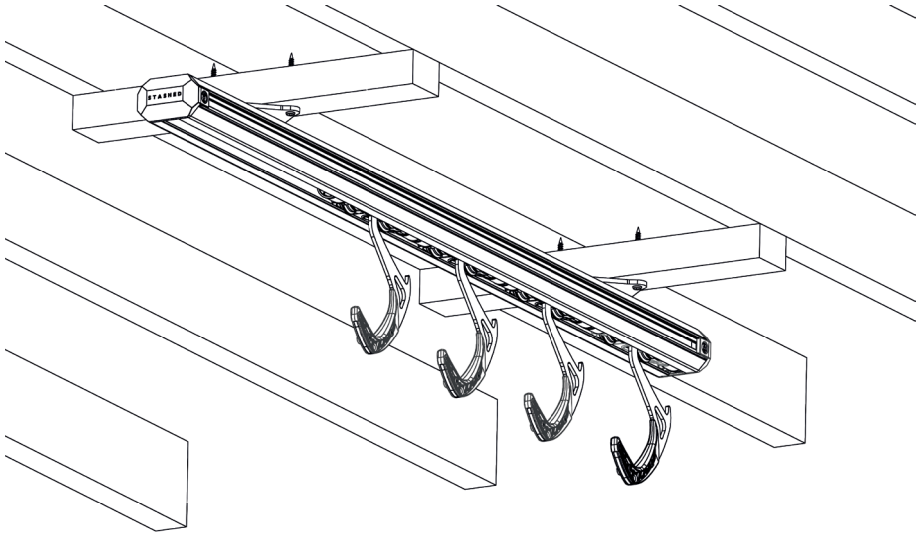



➔ SUGGESTED MOUNTING LOCATIONS

OPEN ENDED AND FREE SPACE

- The SpaceRail Kit can be mounted parallel with a wall with both ends of the system accessible, or can be in complete free space in the centre of a room.

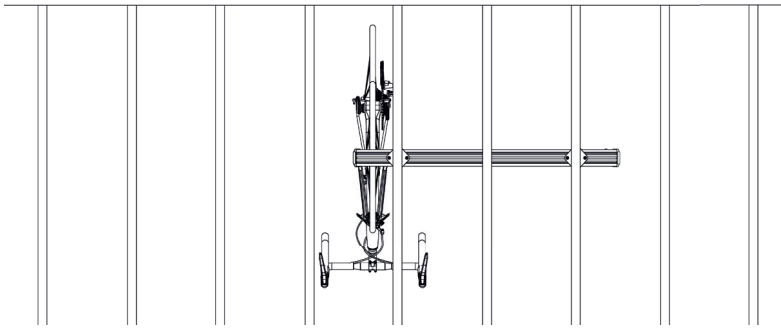

CORNER

- To mount in a corner you need to ensure the end bikes handlebar to do not touch the end wall.
- Measure the end bikes outside of handlebar to stem centre distance. With this dimension in mind, mount the SpaceRail away from the end wall to maximise Rail usable length.

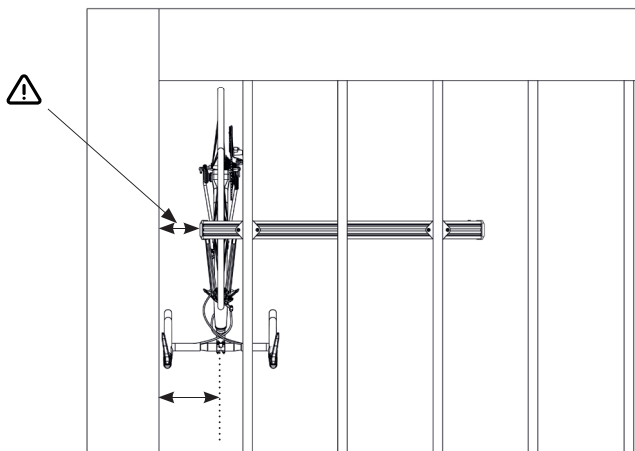



➔ MOUNTING PARALLEL TO A WALL

- The distance to mount your SpaceRail Kit away from any parallel wall is dependent on the size of your bikes and if rotation is required once hung.
- Look for the largest bike you are planning on storing and measure the length and depth to ensure it can spin freely once hung. On bikes with wide handlebars this dimension might also need to be taken in to account.
- For optimum performance the bikes should not rest against the wall once hung up, although this is possible providing hooks are not angled in the rail.
- As a general rule, the Rail is normally mounted between 600-700mm from any walls or other objects to ensure bikes can spin and slide freely.

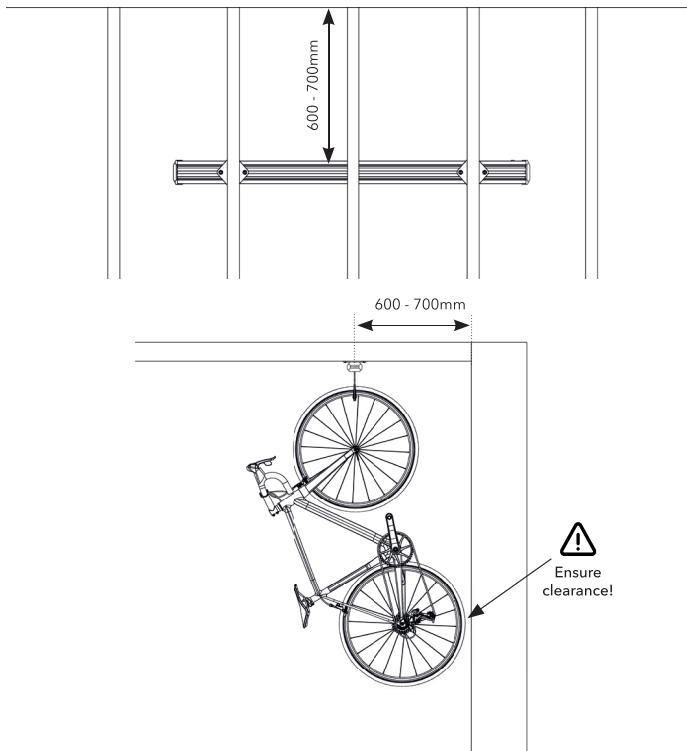



INSTALLATION

➔ LOCATE POSITION AND MARK RAIL

⚠ THE RAIL KIT MUST BE SCREWED TO A ROBUST STRUCTURE AND NOT SOLELY IN TO PLASTERBOARD!

- Ensure the points where the Ceiling Plates are mounted are flat, of solid structure and parallel. If not then the Rail could be mounted at an angle, misaligned or twisted and will not function correctly.
- Measure distance between mounting points and mark Rail with an erasable pen where the centre of the Ceiling Plates are to be located. Alternatively use removable tape to indicate the position.
- If you are installing more than one Rail then ensure suitable mounting points are available for all Ceiling Plates on subsequent Rails.

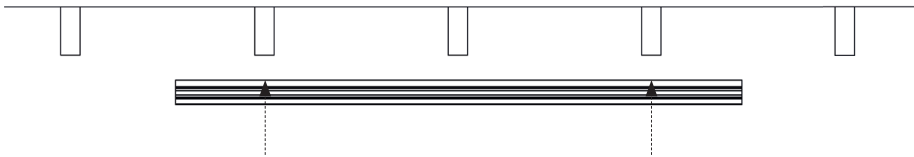



④ ASSEMBLE CEILING PLATES

- Place the M6 x 12mm Bolts through the countersunk holes in the Ceiling Plates and loosely screw to the T-Nuts. Do not tighten fully.

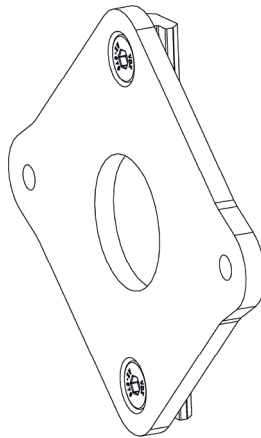
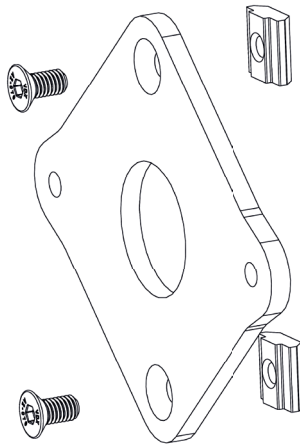



⊕ ASSEMBLE END CAPS

If applicable

- Place the M6 x 12mm Bolts through the countersunk holes in the sides of the End Cap and loosely screw to T-Nuts. Do not tighten fully.

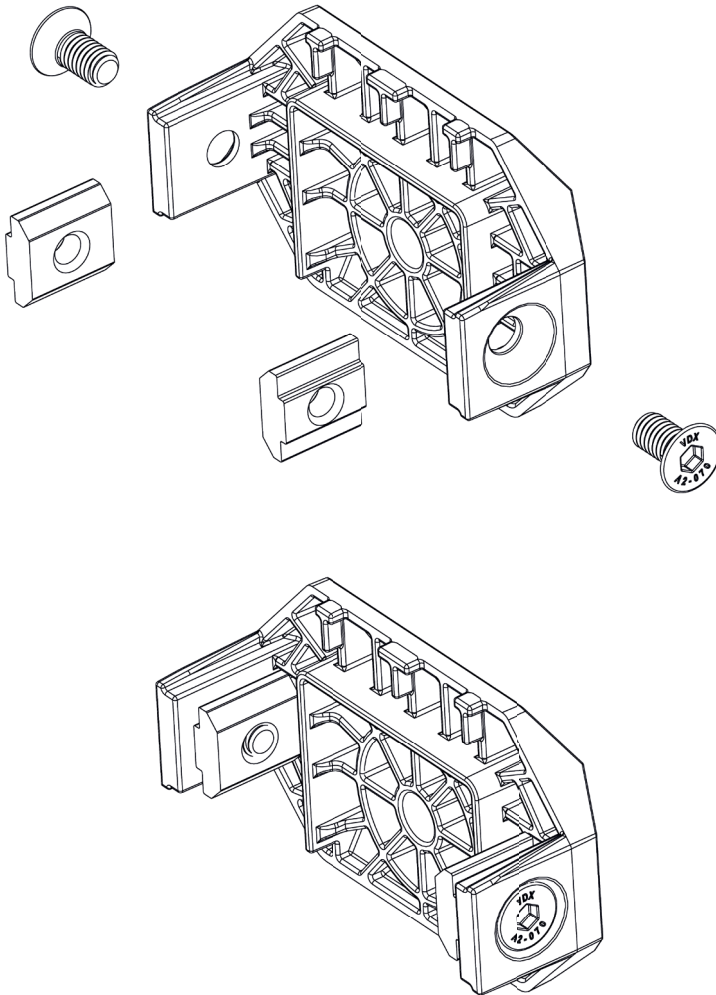



⊕ ASSEMBLE JOINER

If applicable

- Place the M6 x 12mm Bolts through the countersunk holes in the sides of the Joiner and loosely screw to T-nuts. Do not tighten fully.

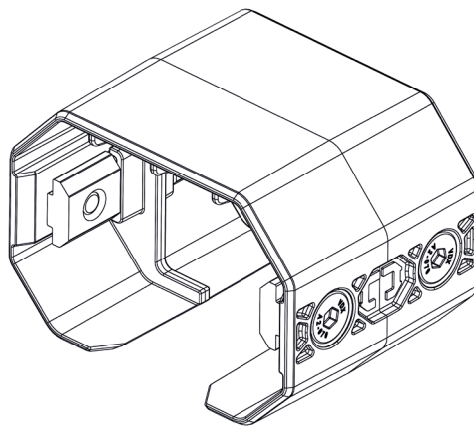
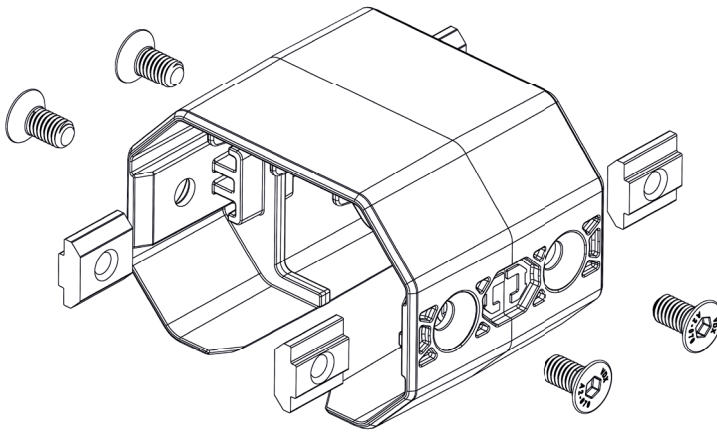



④ SLIDE CEILING PLATES TO REQUIRED POSITIONS

- Slide the Ceiling Mount Assembly into the Rail by aligning and inserting the T-nut into the central section of the top of the Rail.

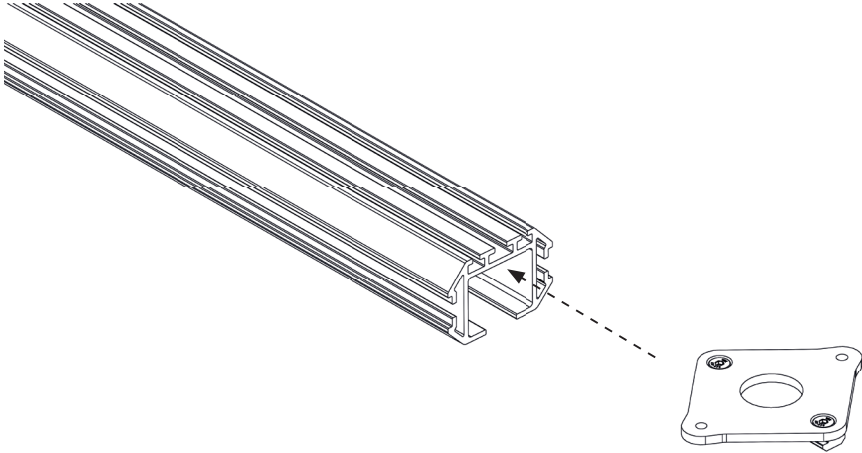

- Slide Ceiling Plate to positions marked earlier and tighten to 7Nm with 4mm Hex Key.

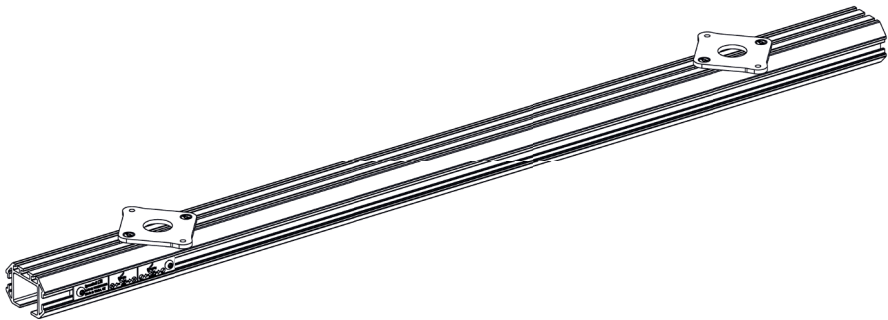



③ HOLD RAIL IN POSITION AND ATTACH

- Hold Rail in the correct position on the ceiling so Ceiling Plates align with your mounting locations.
- Mark screw hole positions with a pencil and drill 3mm pilot holes, being sure to avoid water and gas pipes and electric cables.
- Screw Ceiling Plates to Ceiling using 4 x Wood Screws

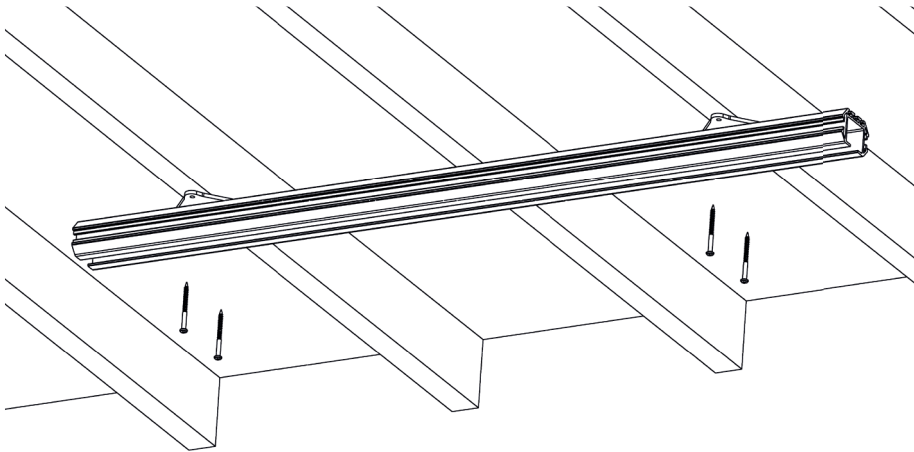

Note: Ensure Rail is level, parallel with any surrounding objects and not bent, twisted or distorted from the installation process. Check using a spirit level. You may need to add shims or packing pieces under the Ceiling Plates to get correct alignment.

④ INSTALL MARKING PLATE

- Place M6 x 10mm Bolt through Marking Plate and loosely thread in to T-Nut. Slide assembly in to side of Rail and tighten Bolts to 2.5Nm.

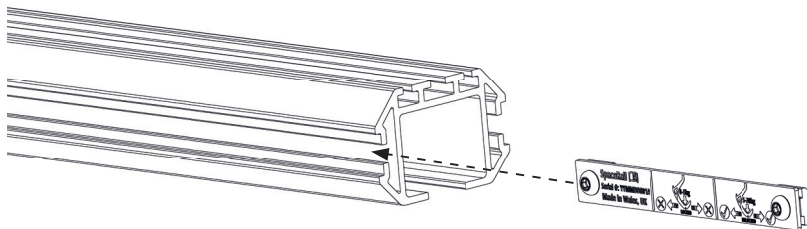



➔ INSTALL EXTENSION RAIL KIT

If applicable

- Before fitting the second Rail to the mounting structure, attach the Rail Joiner to the Rail and loosely tighten the M6 x 12mm Bolts to hold it in place.

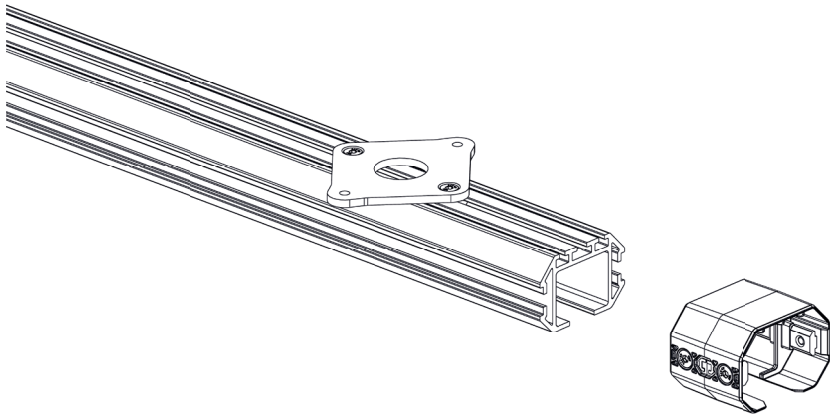

- Mark and trial fit the second Rail as per the first.
- Fit the second Rail to the first Rail - keep well supported. Mark mounting locations and then repeat installation of Ceiling Plates.
- Do not rely on the Joiner component alone to support the second Rail!
- Ensure both Rails are parallel and aligned concentrically. Screw the second Rail to the ceiling and equally tighten bolts in Joiner to 2.5Nm.

⚠ WARNING: DO NOT MOUNT WITH CENTRE OF JOIN MORE THAN 300MM FROM THE CENTRE OF A CEILING PLATE.

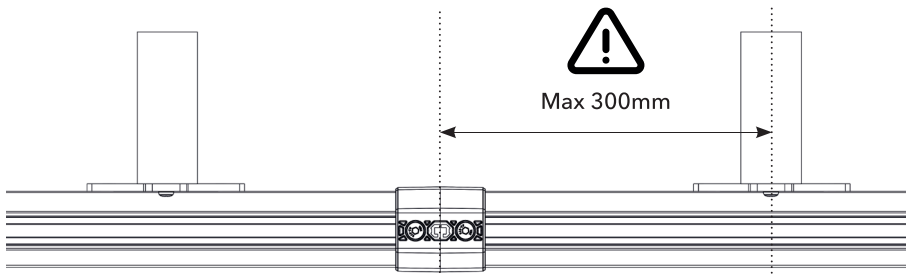



➔ INSERT END CAPS

- Align T-nuts to Rail and slide End Cap into Rail and tighten Bolts equally with a 4mm Hex Key to 2.5Nm.

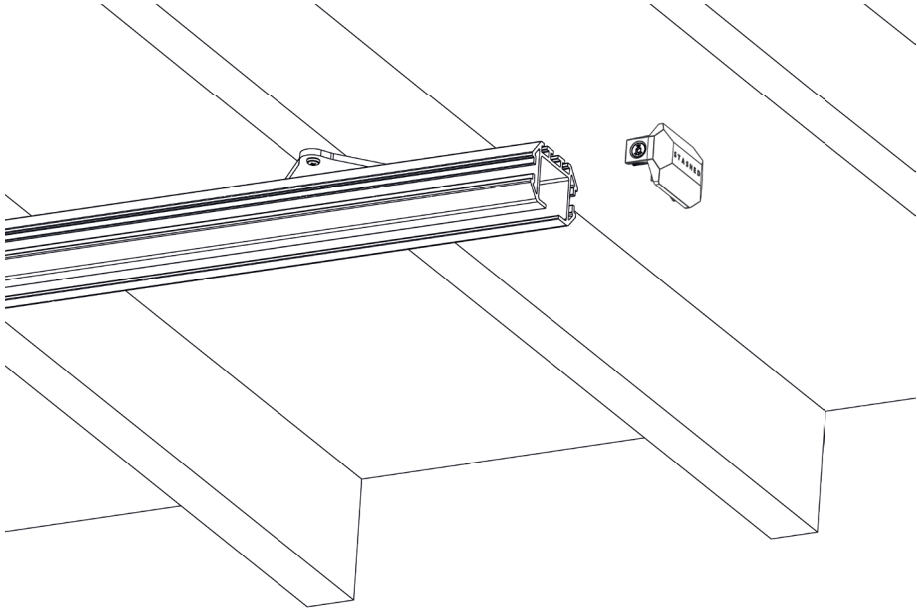

- Insert Trolleys in to Rail (see separate instructions) and ensure they run freely and smooth the whole length of the Rail. Repeat process for second End cap.



FAQ

My Bike Hook keeps rolling on its own

- Check the level of your Rail. Adjust with shims or packing components if necessary.

Can I shorten the Rail?

- Yes! You can cut the Rail to any length you require, but be sure to deburr the ends well with a small file. We recommend using a power chop saw with blade suitable for aluminium. Do not attempt this with a hack saw.

My Trolley gets stuck in the joint

- Rails are not positioned or aligned correctly. Remove all bikes, adjust Rails and refit.

I cannot spin my bikes or access them easily

- Change bike order to improve access.
- Rail length is not long enough so add additional SpaceRail Extension Kit.

How many Rails can I join?

- The number of Rails that can be joined together is unlimited and is only constrained by the support structure. Consult a structural engineer to determine the maximum load the structure can support.

Can I recycle Stashed Products packaging at home?

- Yes! Absolutely! All our packaging is biodegradable in normal home composting or can be recycled in household recycling collections.

WARRANTY/RETURNS

All hardware are covered by a 2-year no quibble warranty.
Please see our website for full details.

If any issues arise outside of the warranty period, then we have designed our products to be easily serviceable to ensure they have a long life in service. All parts are available separately from our website.

If you have problems with your product or questions, please contact us for support.



MAINTENANCE

Your Rail Kit is generally very low maintenance and should give years of use. Some basic maintenance tips:

- Ensure the Rail is kept clean and free from debris, this is especially important on the faces where the Bike Hook wheels run.
- Clean your Rail with a soft cloth or use compressed air to remove debris from hard to reach areas.

PERIODIC CHECKS

- Structural integrity of the mounting area.
- Tightness of all bolts and screws.
- Wear to any components such as wheels or impact areas.
- Ensuring free movement of trolleys when loaded.
- Ensuring mechanisms function correctly when unloaded.



NOTES



NOTES



STASHED

LIFE STORED BETTER

MADE IN WALES by STASHED PRODUCTS

Unit 1, Y-Glyn, Llanberis, Caernarfon, Gwynedd, LL55 4EL, UK

www.stashedproducts.co.uk
sales@stashedproducts.co.uk

+44 (0) 3301 334 836

—

Got a great install? Share it at

@STASHEDPRODUCTS

