

# ASSEMBLY INSTRUCTIONS

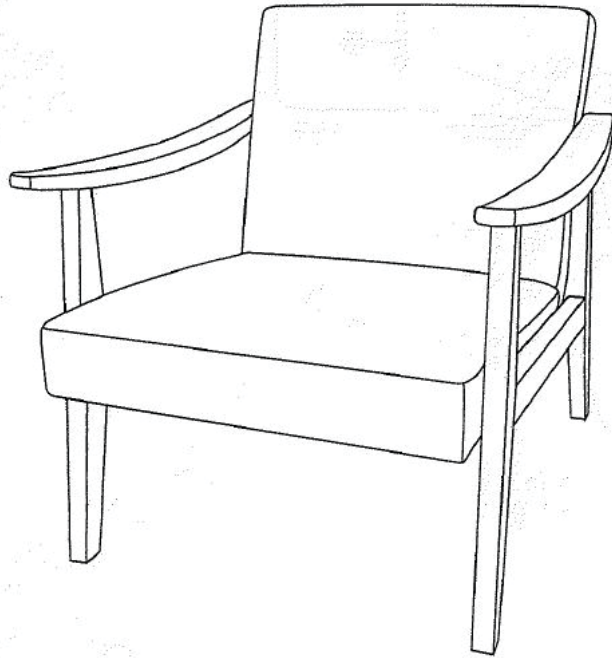

1.

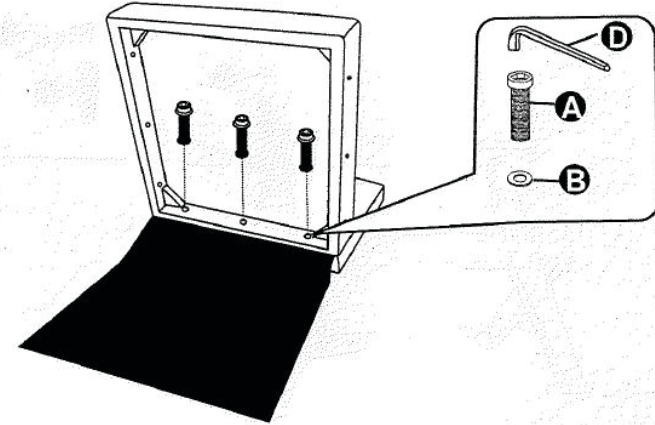



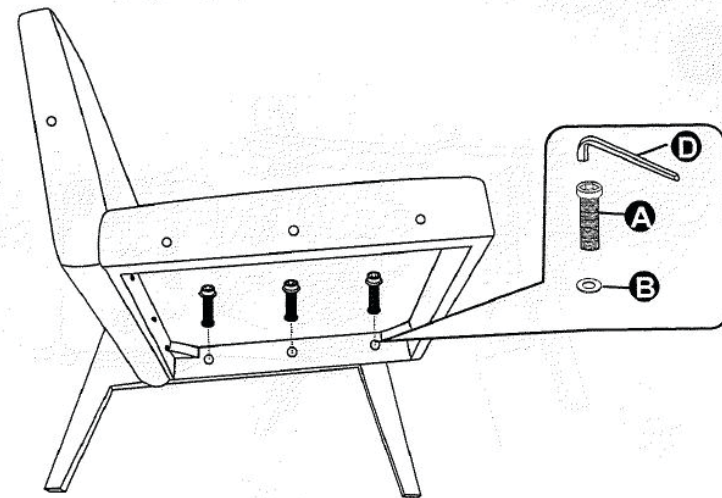

Assemble the base to the back. Insert the screws into the holes and tighten. Tighten to approx 90%, not too tight.

2.



Assemble the base to one side frame. Insert the screws into the holes and tighten. Tighten to approx 90%, not too tight.

HARDWARE LIST	CODE	PARTS	QTY.
	A	M8x50MM 	11
	B	Washer 	9
	C	Plug 	2
	D	ALLEN KEY 	1

3.

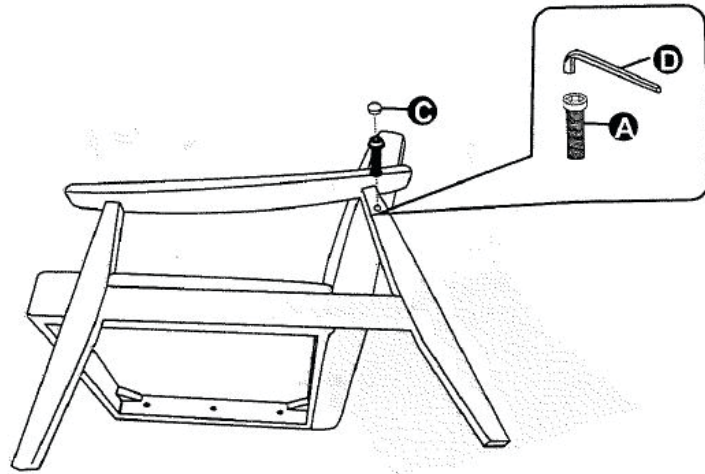

Insert the screw into the hole and tighten. Tighten to approx 90%, not too tight.  
\*Don't use the washer on this step\*

5.

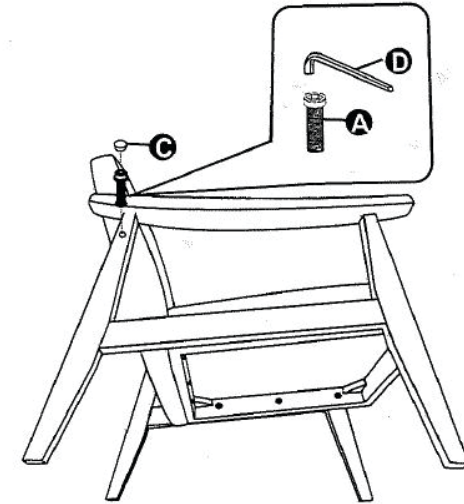

Insert the screw into the hole and tighten. Tighten to approx 90%, not too tight.  
\*Don't use the washer on this step\*

4.

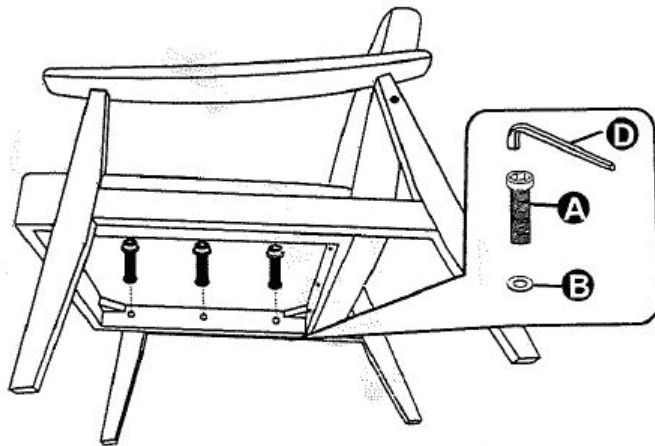

Assemble the base to second side frame. Insert the screws into the holes and tighten. Tighten to approx 90%, not too tight.

6.

Tighten all screws to 100%.  
Stick the black fabric on the underside of base  
(see below image).

7.

Place wooden plugs in these holes and gently knock in until tight.

