

# VAD PRO

by CANchecked

User Manual for:  
VADpro VAD15  
CANchecked MFD15  
MFA2.0 Gen2



# Content

- 1 Description and scope of delivery ..... 4
- 2 Connection of the plugs ..... 5
- 3 Navigation on the display ..... 7
  - 3.1 Using the buttons on the display ..... 7
  - 3.2 Using of a separate rotary knob..... 8
- 4 Connecting to the *oDSS* ..... 9
- 5 Updating the MFD15 Gen2..... 10
  - 5.1 5.1 Online update from the *oDSS* ..... 10
  - 5.2 Wired update via USB..... 10
- 6 The *oDSS* ..... 12
  - 6.1 Configuration ..... 12
    - 6.1.1 Device information ..... 13
    - 6.1.2 General settings..... 13
    - 6.1.3 Units ..... 14
    - 6.1.4 Pages ..... 15
    - 6.1.5 Shift light ..... 15
    - 6.1.6 Gears ..... 15
    - 6.1.7 Analogue inputs..... 17
    - 6.1.8 Sensor settings ..... 18
    - 6.1.9 Display License..... 18
  - 6.2 Live Log ..... 20
  - 6.3 Upload File ..... 20
- 7 Multi Purpose Pins ..... 21
- 8 Working with the DSS on the PC..... 22
  - 8.1 The TRI file..... 22
  - 8.2 TRI editor..... 24
    - 8.2.1 Handling ..... 24
    - 8.2.2 enhanced mode ..... 26
    - 8.2.3 Setup of analog inputs via DSS..... 27
  - 8.3 Log Viewer..... 29
- 9 FAQ..... 30
  - 9.1 Display does not turn on..... 30
  - 9.2 I don't get any data..... 30
  - 9.3 Gear indicator does not work ..... 30
  - 9.4 My Performance Meter runs permanently ..... 30

9.5	How do I change my startup screen?.....	30
9.6	How can I fine-tune a Can Bus sensor? .....	30
9.7	How can I perform a reset .....	31

# 1 Description and scope of delivery

Thank you for purchasing your VADpro VAD15 / CANchecked MFD15 Gen2. With the VADpro data display, you can display live data from your vehicle while driving, *log sensors* and use many other functions that are presented to you in this manual. In some cases, additional licenses are required for the functions.

This guide applies not only to the VADpro VAD15 / CANchecked MFD15 Gen2, but also to MFA2.0 Gen2.

This guide explains how to operate and handle your Gen2 data display. In addition to the connection, setup and navigation, this manual deals specifically with the individual setting of the data display, as well as the connection and operation of our "online display setup software" (*oDSS*).

You received your data display with a vehicle-specific bracket or as a pure circular display. Always included are:

- the Quickstartguide
- 2 anti reflexfoils
- CANchecked stickers
- two Molex connectors (6 pin and 12 pin), a selection of different pre-crimped leads, pins for self-crimping and two 1kohm resistors

Your display itself has an OLED display, an LED, a Wi-Fi hotspot, three Molex jacks on the back and a MicroUSB port on the board. This is not accessible without dismantling the display and usually does not have to be used by the user. Your data display will be delivered with a selection of *TRI files* pre-installed in the file system.

Terms associated with the data display are shown in italics in this guide for better understanding.

## 2 Connection of the plugs

To operate your MFD15 Gen2 via the Can bus, only four wires are required:

- 12 volts on-board voltage, ideally ignition plus - > Pin B5
- Ground -> Pin B6
- Can High (*CanH*) -> Pin C7
- Can Low (*CanL*) -> Pin C8

The wires of *CanH* and *CanL* should always be designed as twisted pairs in order to minimize interference signals.

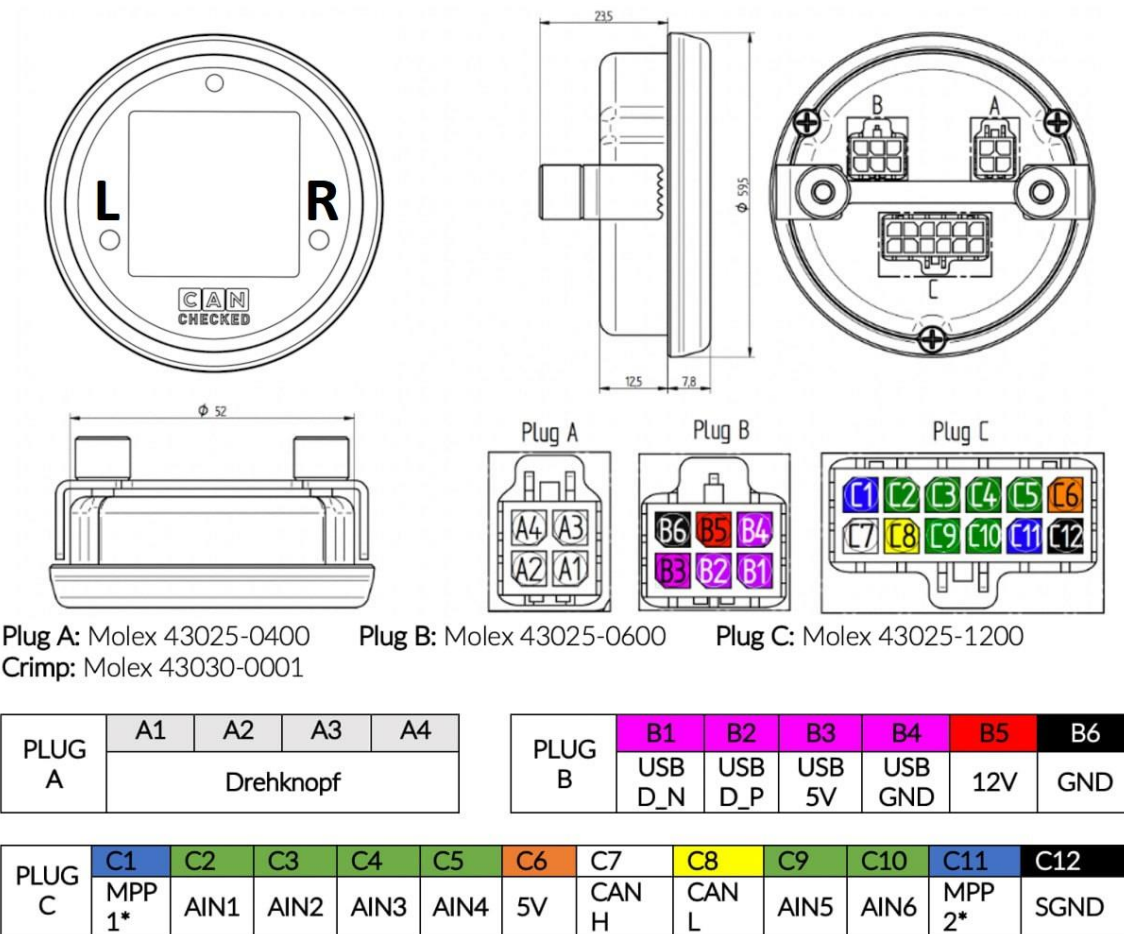

Figure 1: MFD15 Gen2 Pinout

Of course, *CanH* and *CanL* are not necessarily necessary for operation. Via the six analog inputs (*AINs* – analog inputs) you can also feed the 0-5 volt voltages of analog sensors into the display and have them converted by the display and monitored on it.

By default, four of the *AINs* are preconfigured for different sensors:

- *AIN1*: Oil temperature (*OilT*) -> Pin C2
- *AIN2*: Exhaust gas temperature (*EGT*) -> Pin C3
- *AIN3*: Oil pressure (*OilP*) -> Pin C4
- *AIN4*: Boost (*MAP*) -> Pin C5

The analog inputs five (pin C9) and six (pin C10) are not preconfigured.

The power supply for operating the analog sensors can also be realized directly via the display. Pin C6 is 5V, and the sensor ground can be obtained from the SensorGround C12. The maximum current of 0.5 amperes should not be exceeded.

Furthermore, the MFD15 Gen2 has two MultiPurpose Pins (*MPPs*). Various functions can be realized via these pins. Read more in Chapter 7.

Basic settings such as active *TRI file*, can *speed* and termination can be adjusted directly via the display. If the Can Bus connection is successful, the symbol in the *topbar* is displayed in green, if it is not successful, the symbol is displayed in red. The *TRI file* is engine-specific and is described in chapter 8.1.

All further settings are made via Wi-Fi connection via the *oDSS*. By default, Wi-Fi is disabled on the MFD15 Gen2. The *TRI file* can be edited via the *oDSS* or for *TRI files* for freely programmable engine ECUs via the *DSS*.

The *oDSS* starts web-based without installation via the browser of your device.

The *DSS* must be downloaded and installed for use. The download is free of charge at <https://www.canchecked.de/downloads-category/dss-display-setup-software/>. The *DSS* is available for Win32, Win64 and MacOS.

In the meantime, we have produced illustrated installation instructions for numerous vehicles. These can be found on our website under [www.canchecked.de/help/einbauanleitungen/](http://www.canchecked.de/help/einbauanleitungen/). If you have a CANchecked data display with a plug-and-play OBD data cable, it is recommended to connect it briefly with the data display to the OBD socket before final installation behind the fairing in order to check the correct connection and familiarize yourself with the user interface.

### 3 Navigation on the display

Your data display can be operated via the two buttons on the front as well as using the CANchecked knob (CC20001).

#### 3.1 Using the buttons on the display

The two buttons (L/R) are embedded on the left and right of the front of the plexiglass pane.

**Attention:** With the MFA 2.0 Gen2 these buttons are not available, for this reason a rotary knob is always included in this configuration.

If both buttons are pressed and held simultaneously (L+R) before switching on the data display, you will be taken to the menu instead of the regular page view, in the menu you can define the basic settings.

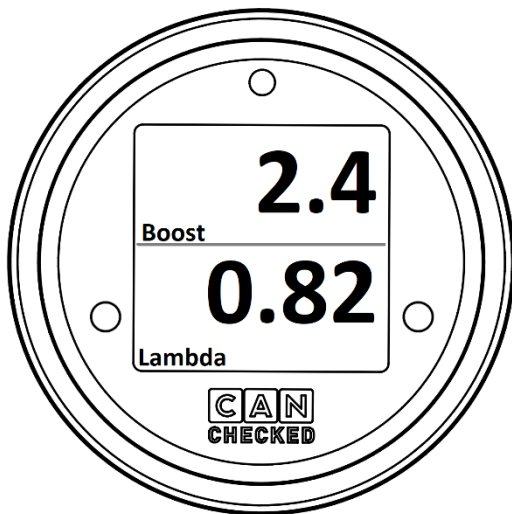

Figure 2: Page view

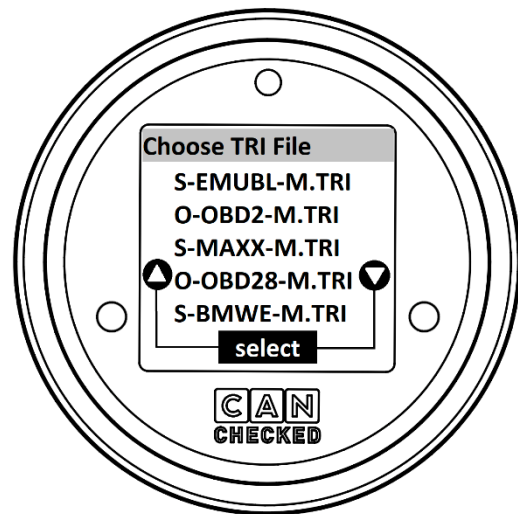

Figure 3: Menu

The assignment of the functions of the buttons can be freely defined in the *oDSS*. By default, the buttons are assigned as follows:

The left button (L) changes with a short press:

- In page view, moves the page to the left
- In the menu the selection to the top

The right button (R) changes with a short press:

- On the page view, moves the page to the right
- In the menu the selection down

Briefly pressing (tapping) both buttons simultaneously (L+R):

- Has no effect in page view
- Confirms the current selection in the menu

The long press (three seconds) of both buttons at the same time (L+R):

- Turns Wi-Fi on or off on the page view
- Has no effect in the menu

### 3.2 Using of a separate rotary knob

The MFA 2.0 Gen2 comes standard with a rotary knob. However, the rotary knob can also be connected as an additional add-on to any MFD15 Gen2 to extend the functionality.

If the rotary potentiometer is pressed and held before switching on the data display, you will be taken to the menu navigation instead of the regular page view.

The assignment of the functions of the rotary potentiometer can be freely defined in the *oDSS*. By default, the buttons are assigned as follows:

Turning the knob to the left changes:

- In page view, moves the page to the left
- In the menu the selection to the top

Turning the knob to the right changes:

- On the page view, moves to the right
- In the menu moves the selection down

The short-term pressing (tapping) of the rotary knob:

- Has no effect in page view
- Confirms the current selection in the menu

The long press (three seconds) of the rotary knob:

- Turns Wi-Fi on or off on page view
- Has no effect in the menu



## 4 Connecting to the oDSS

The oDSS can be run on any browser and Wi-Fi-enabled device. You can use both your smartphone or your laptop.

To connect to the oDSS, the first step is to activate the Wi-Fi hotspot on your MFD15 Gen2. To activate, both buttons (L+R) or the rotary potentiometer must be held down when the ignition is switched on. The display will then show you two QR codes one after the other.

The first QR code is used to connect your device to the hotspot, the second QR code opens the address of the MFD15 hotspot in your browser. Please wait some seconds after scanning the first QR-Code for the device to switch to the second one.

If you cannot scan the QR codes, the name (MFD15) and password (12345678) of the hotspot, as well as IP address (192.168.4.1) for the oDSS are displayed below the QR codes, so that you can also connect via the normal Wi-Fi menu and the browser.

If the connection is successful, the *topbar* is now permanently displayed and the Wi-Fi icon is displayed in green.

**ATTENTION:** If you are connected to the MFD15 hotspot, you will no longer have **regular Internet reception**. If you want to update the data display or upload your own image, the files must **first be stored locally** on your device and can no longer be downloaded from the cloud or similar online services.

Some phones might not be able to connect to the device if the GSM/3G/4G/5G has an active connection, so you might have to temporarily disconnect the cellular network on the phone.

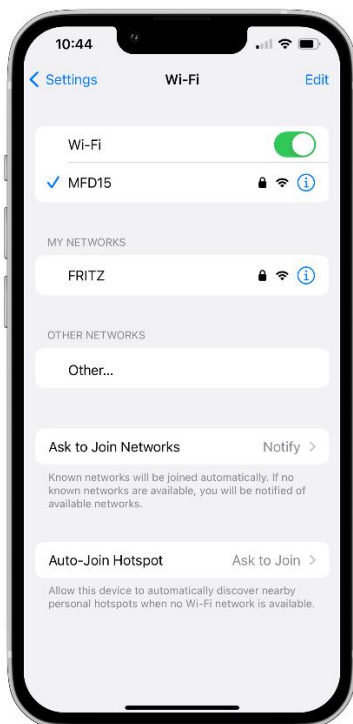

Figure 4: Wi-Fi Settings

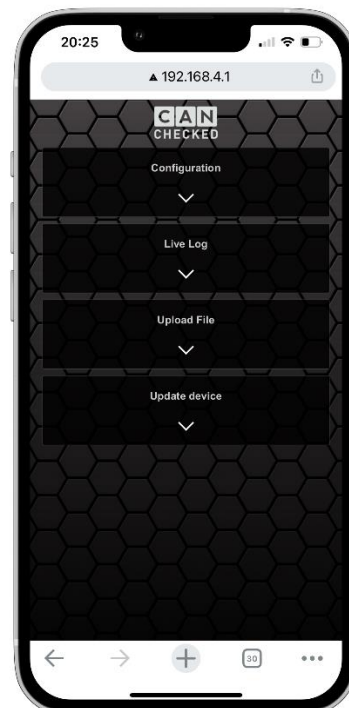

Figure 5: User Interface oDSS

## 5 Updating the MFD15 Gen2

The MFD15 Gen2 can be updated wirelessly or via WLAN from the oDSS, or via USB cable with the CANchecked MFD15Gen2Updater.

### 5.1 5.1 Online update from the oDSS

The Update Device section of the oDSS is used to upload new firmware and file systems.

The firmware is the operating system of your data display, and the file system contains new TRI files.

The .bin files for over-the-air updates can be found at <https://www.canchecked.de/downloads/downloads-mfd15-mfa20-gen2/>.

To update from the oDSS, press the Start Update button and select the appropriate .bin file. The update starts, the bar runs through, and the display then reboots automatically. Afterwards, the WLAN must be reactivated and the connection to the hotspot must be re-established for further configuration.



Figure 6: oDSS Update

### 5.2 Wired update via USB

The MFD15 Gen2 has a microUSB port on the circuit board. To access this, the MFD15 must be disassembled. It is easier to connect the MFD15 Gen2 to a PC via the six-pin Molex connector B. The TTL adapter from the Gen1 does not work here! If your kit does not come with a Molex USB connector, you can pin it yourself with this pinout:



Figure 7: USB Cable Colors

Of course, you can also build the USB cable yourself, if you have the possibility to crimp the Molex contacts yourself. Once you have stripped your USB data cable so far, the individual wires must be professionally crimped and pinned into the six-pin Molex connector as follows:

- White: USB Data- -> Pin B1
- Green: USB Data+ -> Pin B2
- Red: USB 5V -> Pin B3
- Black: USB GND -> Pin B4

Once you have successfully connected your MFD15 Gen2 via USB, you will need the CANcheckedUpdater and the appropriate .flash file, both of which can be found here:

<https://www.canchecked.de/downloads/downloads-mfd15-mfa20-gen2/>

In addition, the appropriate driver is also offered on the website. To update the display wired, you need to run the updater and make sure that your MFD15 Gen2 is recognized as shown in the following picture.

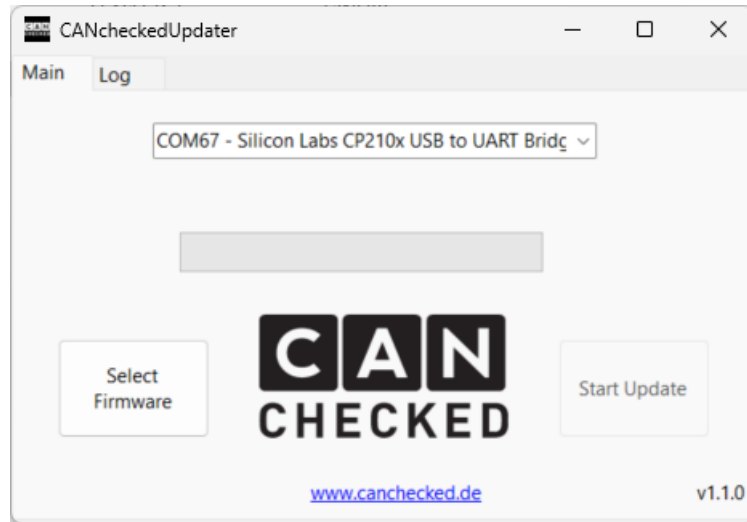

Figure 8: CancheckedUpdater

Now you can use the "Select Firmware" button to load the .flash file that you previously downloaded from the website into the updater. After the updater has checked the file, the previously greyed out "Start Update" button becomes visible, and the update is started by clicking on the button. You can follow the progress in the loading bar of the updater. After a successful update, your display reboots.

## 6 The oDSS

Connect to the oDSS as described in chapter 4 , you can now make all settings on your MFD15/MFA2.0 Gen2 online in your browser. By clicking on the **arrow**, you can expand one of the four sections.

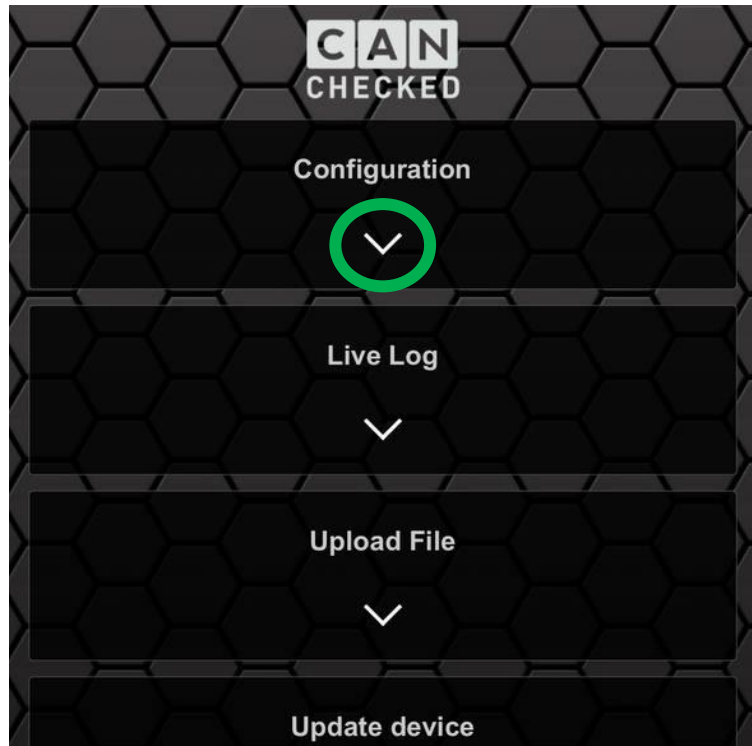

Figure 9: oDSS User Interface

### 6.1 Configuration

The *Configuration* section contains nine sub-items, which can be opened by clicking on the texts in the square brackets.

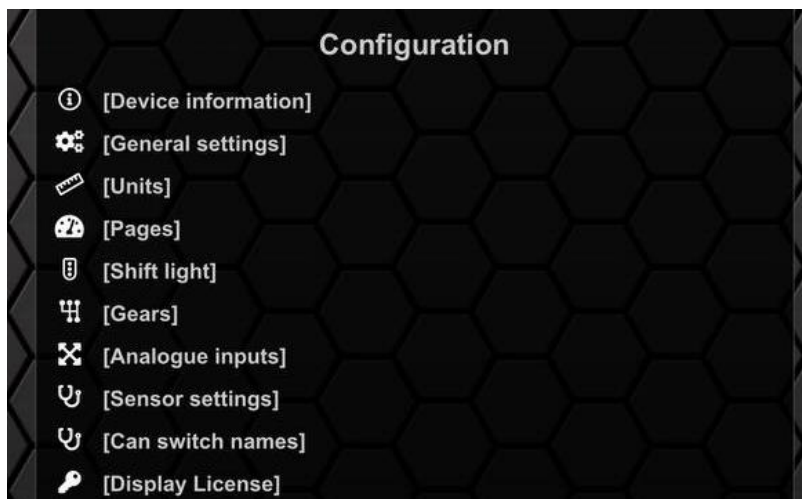

Figure 10: Sub-items Configuration

### 6.1.1 Device information

The sub-item *Device* information shows you all important information about your device at a glance. You can see which firmware version your data display is on, what percentage of memory is occupied, which serial number your data display has, and of course which *TRI file* is active. You can find out more about the *TRI file* in chapter 8.1



Figure 11: Device information

### 6.1.2 General settings

All settings are offered to you as a slider or in a drop-down menu. Figure 12 shows a screenshot of the *general settings* in the *oDSS*. The individual functions are outlined below.

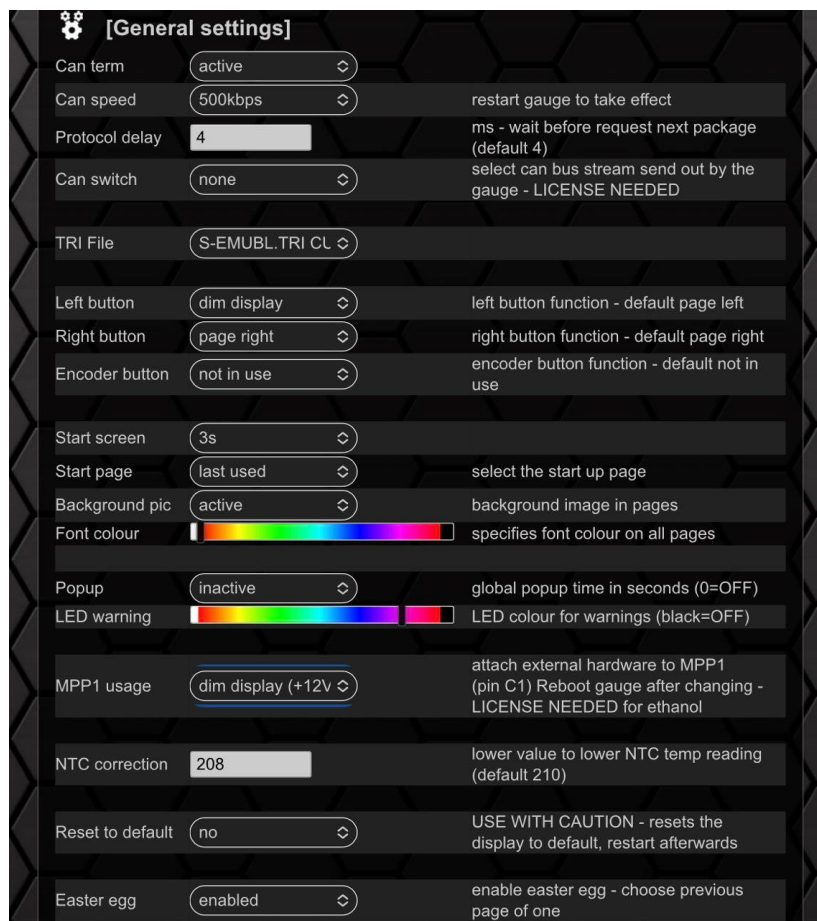

Figure 12: General settings

In the sub-item *General* settings you will find the following settings:

- Can Communication
  - Termination
  - Speed
  - Protocol Timeout
  - Can Switching
  - Active TRI File

- Assignment of buttons
  - left button
  - right button
  - turning knob
- Appearance
  - Start picture
  - Start page
  - Wallpaper
  - Color
- Warnings
  - Popup duration
  - Color of the warning LED
- MPP1 Usage
  - Assignment of function to *MPP1*
- *NTC correction*
  - Corrects the NTC temperature reading. The lower the value the lower the red temperature – default 210
- Button to reset the display
  - Resets your data display to factory settings

### 6.1.3 Units

In this submenu you can set the desired units. In total, there are four different types of *sensors* available:

- Pressure – bar or psi
- Temperature – Celsius or Fahrenheit
- Speed – km/h or mph
- Combustion ratio – lambda or AFR



Figure 13: Units used

If you prefer to see your boost displayed in kpa instead of bar, you can change the multiplier under Sensor Settings (see chapter 6.1.8). Furthermore, you can also directly change the name of your sensors under Sensor Settings.

#### 6.1.4 Pages

In the sub-item *Pages* you can configure the appearances of your up to eight *pages*. Here you can choose from seven different, predefined views and hide *Pages* completely. In addition, you can activate the animation of your *sensors* to simulate the behavior during operation.

Depending on the selected view, you can be displayed by one to six *sensors per page*. You can activate the display of the maximum value for each *sensor* individually and also change the colors of the needles or bars for numerous views. Figure 14 shows the *Pages* interface of the *oDSS*.

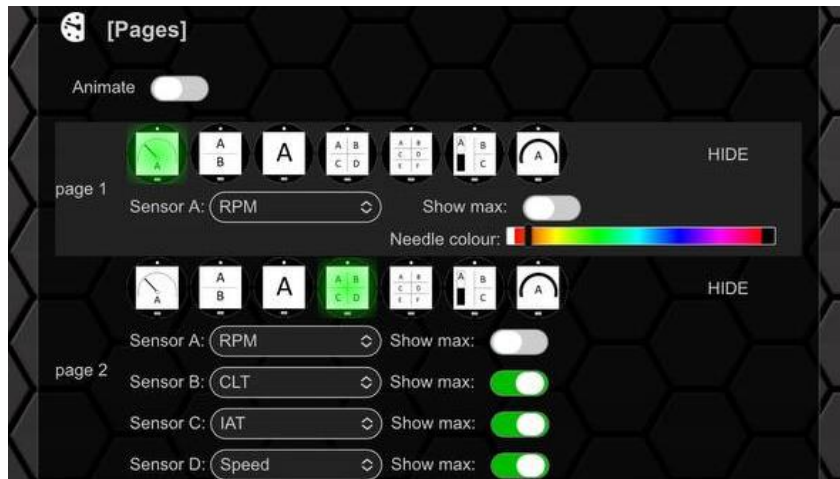

Figure 14: Pages

#### 6.1.5 Shift light

To configure your shift light above the OLED, you have to open the sub-item *Shift light*.

In this menu you can configure the speed at which the shift flash should flash, the general brightness of the shift flash and the colors at the corresponding speeds. A screenshot is shown below.

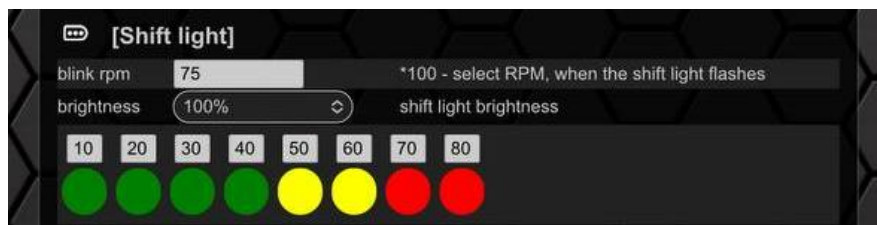

Figure 15: Shift light

#### 6.1.6 Gears

Your MFD15 Gen2 can also be used as a gear indicator. To do this, please select the page for gear display in the *Pages* submenu.

The gear can either be transmitted as a can bus message, or gear can be calculated from the *sensors* speed and rpm.

For the display of the gear via Can Bus message, the corresponding sensor values must be entered.

For the gear calculation from speed and rpm, the *sensors* Speed and RPM must be assigned appropriately (Figure 16) and the appropriate gear ratios entered in the *Gears* submenu.



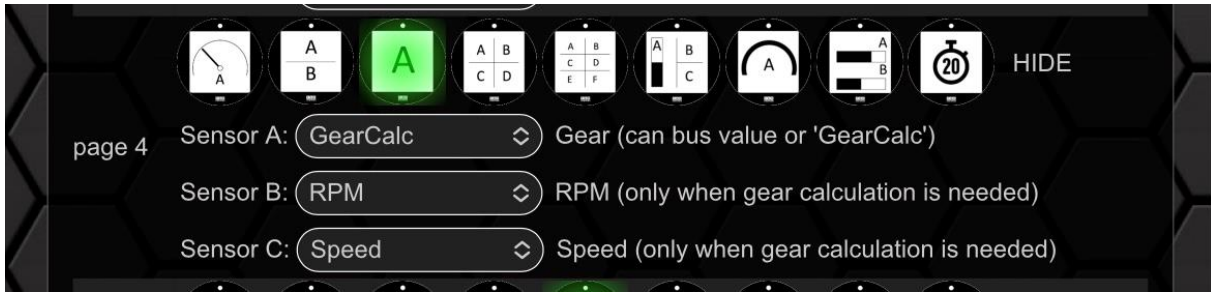

Figure 16: Gear adjustment side

The gear ratios must be identified while driving but are displayed on the display side as a small value (ratio) for the current gear when Wi-Fi is active and the numbers only have be entered and transferred to the *oDSS*.



Figure 17: Gear setting Wi-Fi

In the following figure, the power ratios for an exemplary transmission are entered. By clicking on *save*, your values are saved and taken over for driving.

Gear calculation from RPM/speed	
Gear1	120
Gear2	67
Gear3	47
Gear4	34
Gear5	27
Gear6	22
Gear7	1

Figure 18: Gears (Example)



### 6.1.7 Analogue inputs

Your display has 6 analog inputs with 10bit resolution (0-1023).

Already successfully tested and installed sensors as well as their characteristic curves and connection diagrams can be found under [www.canchecked.de/downloads/](http://www.canchecked.de/downloads/). The exemplary connection of our sensors is shown in the following figure.

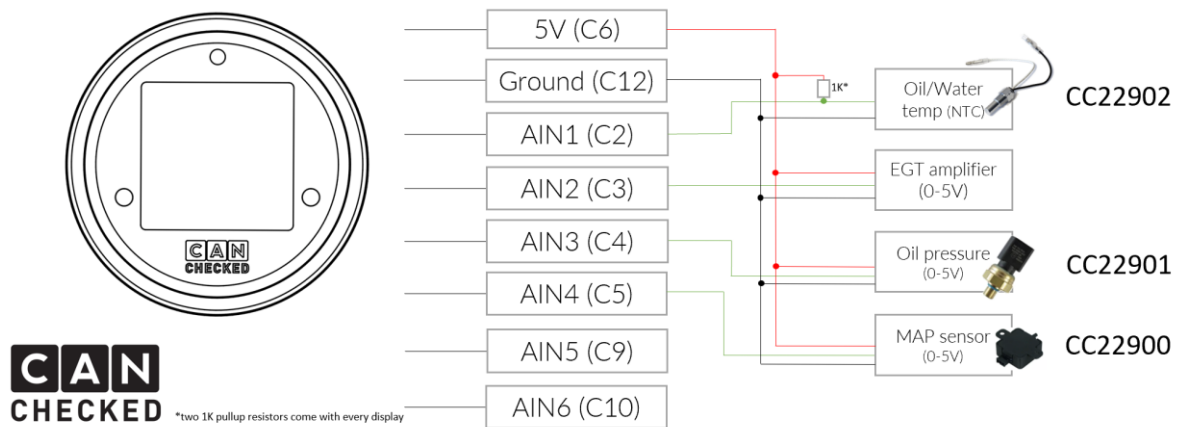

Figure 19: Connecting the AINs

In addition to the physical connection, the *sensors* must also be configured in the *oDSS*. The configuration is done in the submenu *Analogue inputs*. This submenu is shown below.



Figure 20: Analogue inputs

Here you can define the type of sensor (NTC/Mapper), the name of the *sensor* and the corresponding constants for NTC or the values for 0 and 5 volts for linear sensors. A click on *calculate* opens the calculation tool.

### 6.1.8 Sensor settings

In the submenu *Sensor settings*, the individual *sensors* of your *TRI file* can be configured in the most important points. After you have opened the *Sensor settings* item Figure 21.



Figure 21: Sensor settings

Now you can modify the wished *sensor*.

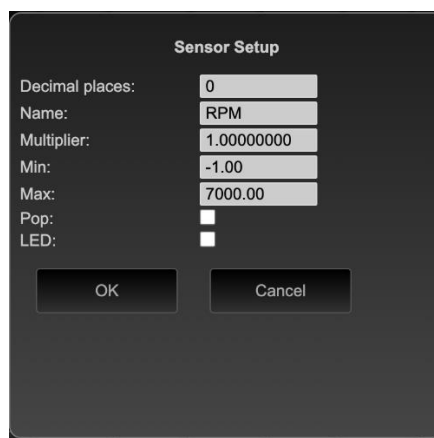

Figure 22: Sensor Configuration

In this window, you can change the following:

- Decimal places
- Name of the sensor
- Global multiplication factor (see Chapter 9.6)
- Min. value (chapter 8.1)
- Max. value (chapter 8.1)
- Deactivate/activate the *pop-up* when exceeding and falling below the min or max values
- Deactivation/activation of the LED when exceeding and falling below the min or maximum value

Once you have made your changes, they must be acknowledged with *OK* and then *transferred* to the display via the save button.

### 6.1.9 Display License

On your data display, you can unlock various additional functions via license key. We currently offer the following options:

- Ethanol Sensor
- Online Logging
- Can Switching

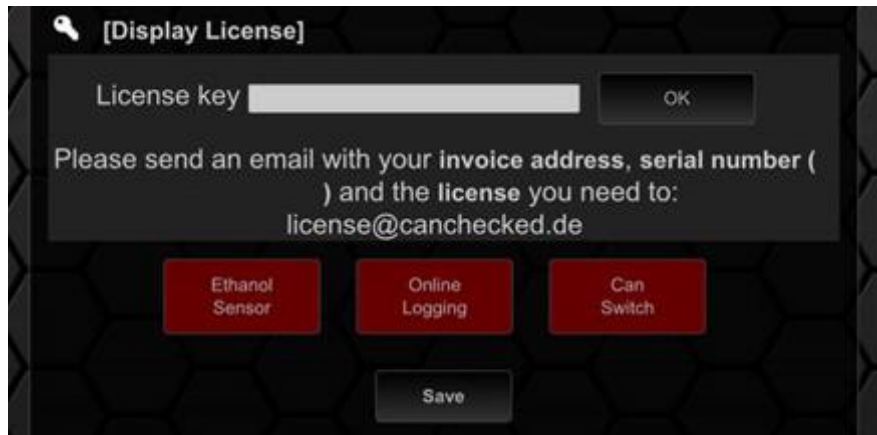

Figure 23: Licenses

To get your license please email us your invoice address and serial number to [license@canchecked.de](mailto:license@canchecked.de). Our team will then send you an invoice as soon as possible and send you the license key after receipt of payment. You can now enter this in the field and activate it by clicking on the OK button. The licenses are device-specific and can be transferred to your next vehicle with the data display.

If you have purchased the Can Switch license and are in possession of the rotary knob, you can set the function "Encoder button" to "Can Switch 1-6". Here you get an overview of buttons 1-6 and their current status. By turning the knob, you reach the buttons and can change the button status by pressing the rotary knob. In the oDSS you adjust the names of the buttons and thus you know exactly which function is active/inactive.

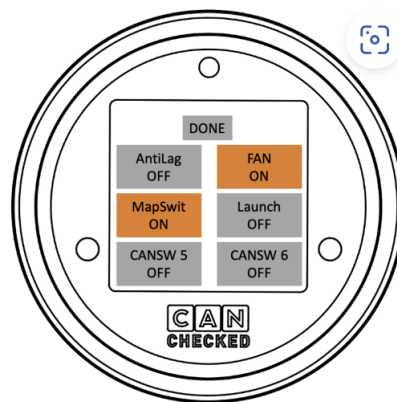

Figure 24: Can Switch 1-6

## 6.2 Live Log

If you have purchased the paid *Live log* license, you can view all *sensors* of your *TRI file* live on your smartphone or PC. You can select *sensors* individually and display them graphically and then export these logs as csv via the *export* button and save them on your device.

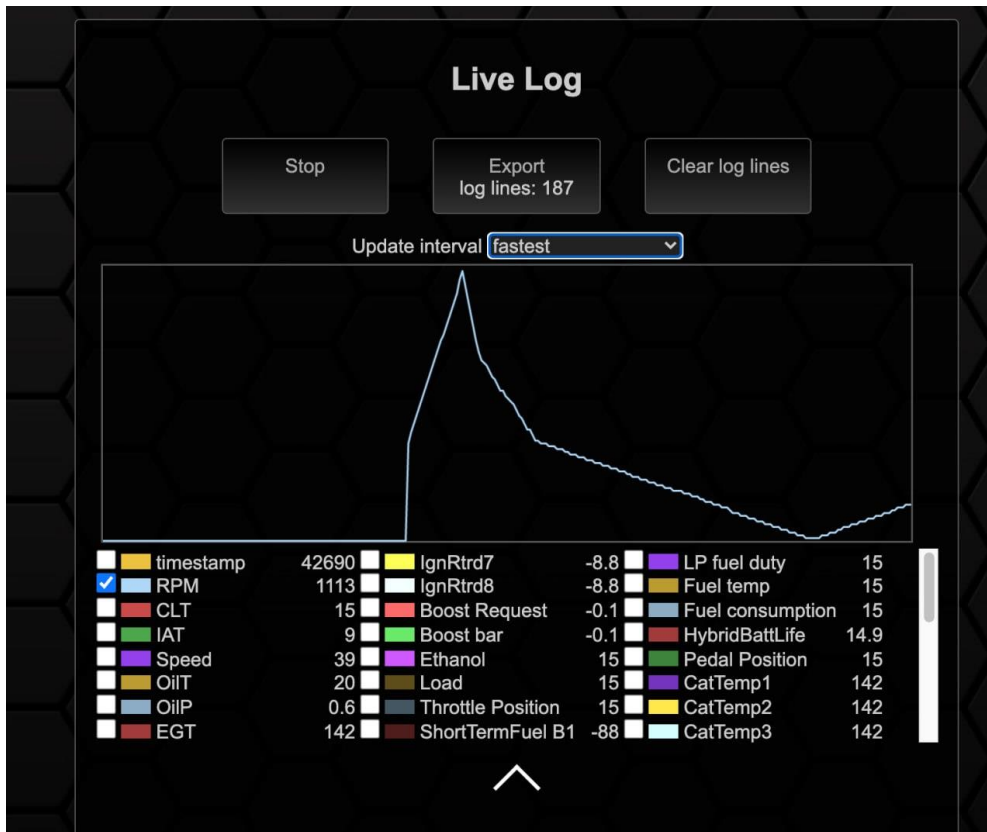

Figure 25: Live log

## 6.3 Upload File

Via the *Upload File* section, you can upload specially created *TRI files* or custom start images. Only files named *logo.bmp* with a bit depth of 24 and a maximum of 128x128 pixels are accepted as startup images.

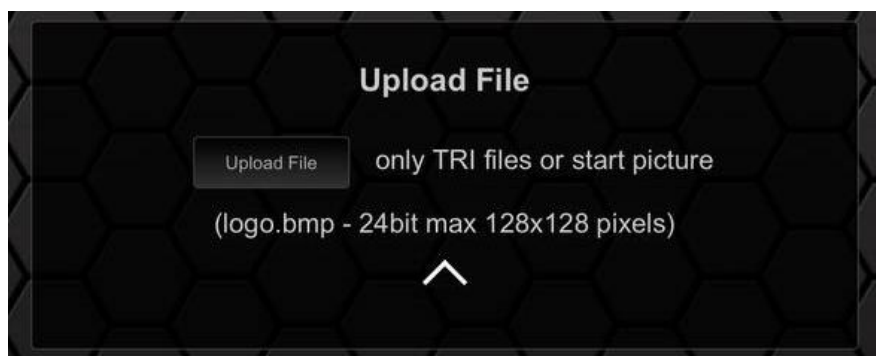

Figure 26: Upload section

## 7 Multi Purpose Pins

### 7.1 MPP1

The MFD15 Gen2 has two multi-purpose pins. *MPP1* (pin C1) is a frequency/switched input and *MPP2* (pin C11) is a switching output.

Frequency signals such as ethanol content or turbocharger speed can be connected to *MPP1* and require an additional license. When wiring an ethanol sensor, a 10k pullup resistor between 5V and the signal line is required.

You can choose to set this pin to dim the display. Wire your +12V light switch to the pin, and the display dims as soon as +12V is feed in to the pin.

### 7.2 MPP2

*MPP2* can be used to switch an output such as N75 clocking or water-methanol injection.

The activation of these functions takes place via paid licenses.

## 8 Working with the DSS on the PC

In principle, all functions in *oDSS* can be used and configured. However, if you want to create or modify your own *TRI*, the *DSS* must be used.

You can download the *DSS* free of charge from our website at [www.canchecked.de/dss/](http://www.canchecked.de/dss/). This is available for both PC and Mac. On our website you will find a quick guide to download and install. Furthermore, you can find the **driver** required for **Windows 7** here. As soon as you have installed the *DSS*, you can execute it, should be able to see the following start screen and click on the CANchecked logo to get to the selection field of the device to be connected.

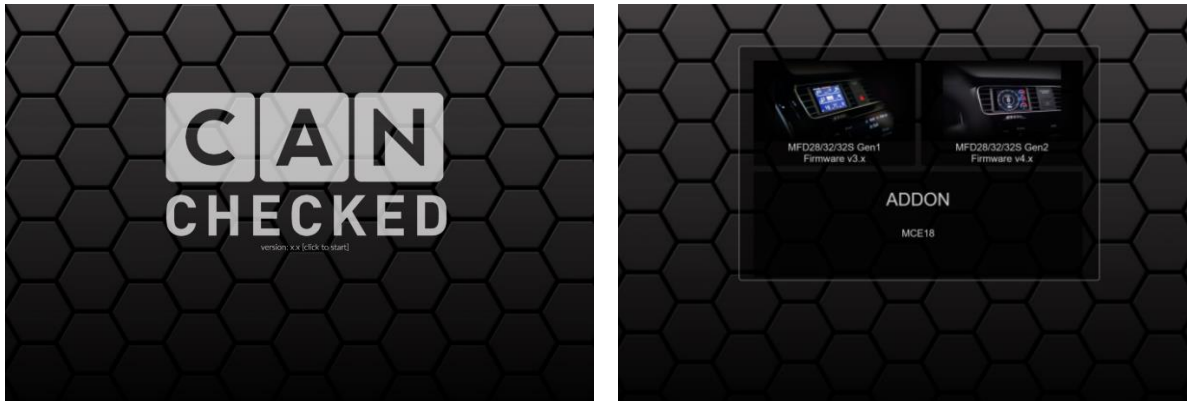

Figure 27: DSS startup

Here you click on the selection field for Gen2 devices (right) and now get to the tab overview. The following tabs are available:

- *Connection*
- *TRI Editor*
- *Pages*
- *Log Viewer*
- *Other settings*
- *Upload*
- *Can log*

The MFD15 Gen2 cannot be connected to the *DSS* via USB. The *DSS* can only be used to edit *TRI files* offline.

### 8.1 The TRI file

The *TRI file* is the heart of your data display. All *sensors* and the associated information are stored in the *TRI file*.

In the following, the structure of a *TRI file* is explained. If you open the file with a text editor, you will find the following structure:

Each row represents a sensor and all metadata associated with the sensor. These 26 metadata are in columns; separated by semicolons. The decimal separator is a period, not a comma. The figure below shows a *TRI file* with two sensors (RPM and CLT) and the metadata associated with the *sensors*.

```

S-EMUBL-M.TRI
1 0000;0600;1;0;2;1;0;0000;0;RPM;1.00000000;0.00000000;0;0.00000000;0.00000000;0.00000000;0.00000000;1;-1.00;7000.00;255;0.00;0;0;0;
2 0000;0602;1;6;2;0;0;0000;0;CLT;1.00000000;0.00000000;0;0.00000000;0.00000000;0.00000000;0.00000000;1;-1.00;100.00;255;0.00;0;0;0;2;

```

Figure 28: TRI File in the text editor

The column position of the 26 metadata is fixed in each row. For example, the Can ID of the respective sensor is always in the second column.

Table 1 shows the column positions, the label, and the purpose and specifics of the metadata. The values marked in blue are only visible in *enhanced mode* in DSS (chapter 8.2.2).

Table 1: TRI Metadata

column position	Designation	Purpose and particularities
1	Header	bus header for OBD/UDS (hexadecimal) 0 = no protocol or specific Can Bus Identifier for protocol
2	Can ID	Can Bus Identifier (hexadecimal) when using OBD/UDS/TP2.0: Address for querying the device
3	Format	0 -> Big endian; 1-> little endian; 2 -> VEMS (seriell); 4 -> IEEE-754 float (length=4)
4	Start byte	First byte in Can Bus packet (0-7)
5	Length	Length in bytes - 1, 2 or 4 for AINs: Attenuation strength 0-249 (0 = no attenuation)
6	unsigned	if the value is negative, please do not tick the box
7	shift Bit	moves the bit within the value to the right by position X
8	CAN Mask	Masks the value before shift (0 -> no mask applied)
9	Decimal places	Number of decimal places
10	Sensor Name	Sensor name (maximum 15 characters, no special characters)
11	initCalc	Can Bus value is multiplied by this number Result=((Can Bus value & MASK)>>SHIFT)*INITCALC+INITOFFSET
12	initOffset	after multiplication this value is added
13	Multiplex / MapperType	OFF; Multiplex ON; MAP (linear analog sensors); NTC (3 constants and pull-up resistor (Steinhart-Hart))
14	start bit / MapperInfo1	Multiplex start bit / Varies by mapper type
15	bit length / MapperInfo2	Multiplex bit length / Varies by mapper type
16	Multiplexer / MapperInfo3	Multiplexer/ Varies by mapper type
17	Multiply / MapperInfo4	Global multiplication factor for sensor (default 1) / Varies by mapper type
18	AIN active	Internal analog sensor only; enables input pin polling
19	Min	Lower warning value
20	Max	Upper warning value
21	RefSensor	reference sensor; only if the RefValue for this sensor is exceeded, warning is active
22	RefValue	Reference value for enabling the alert
24	Pop	Popup active when exceeding or falling below the warning value
25	Blink	LED active when exceeding or falling below the warning value
26	Sensor type	Used for units calculation: 0=none; 1=pressure; 2=temperature; 3=speed; 4=combustion ratio

Our *TRI* files always have the following name:

*X – ABC – X.TRI*

The **first** letter identifies the *protocol* used. The MFD15 Gen2 supports OBD, UDS as well as many vehicle-specific protocols and freely programmable engine control units.

The letters **two to four** identify the engine code letter or ECU. The engine code DAZA becomes X-DAZ-X or a Syvecs ECU becomes X-SYV-X here. For freely programmable ECUs, however, the names can also be longer than three digits (e.g. MaxxECU -> X-Maxx-X). The maximum number of digits including ending is 15 characters.

The **fifth or fifth** last letter in the name of the *TRI* file indicates the units used or the languages used to name the *sensors*, whereby currently only metric units and English sensor names are stored in the file system:

- **-G** stands for the language German and units metric
- **-M** stands for the English language and the units metric
- **-I** stands for the language English and the units imperial
- **-H** stands for hybrid the language is English, the units imperial and metric mixed
- **-U** stands for UK, also a mix of imperial and metric units

## 8.2 TRI editor

In the *TRI editor* you can modify the *TRI file* of your data display. In addition to the *sensors* that come as can messages on your display, you can also create and parameterize the six analog inputs here.

**Attention:** When the display is fully set, the position of the sensors in the *TRI file* should not be changed by deleting or moving, as this refers to the position of the *sensors* on the *pages*.

### 8.2.1 Handling

Below the tab overview you will find the buttons of the *TRI Editor*. The button is divided into five sections.

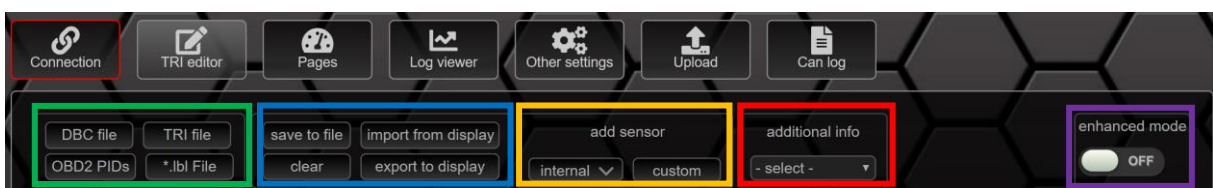

Figure 29: Buttons in the TRI Editor

In the **first area**, you can import *sensors* from different data formats into the *editor*. Possible formats are:

- DBC Files
- TRI Files
- OBD2 PIDs
- \*.lbl Files

In the **second area** you will find the function buttons for saving and deleting the *TRI file* currently loaded in the *TRI Editor*, all other buttons of this area are reserved for MFD28/32.

The **third area** can be used to add *internal* and *custom sensors*. The *internal sensors* include:



- *AIN1*
- *AIN2*
- *AIN3*
- *AIN4*
- *AIN5*
- *AIN6*
- *displayVolt*
- *displayTemp*
- *PWMoutDuty (MFD28/32 Gen2 only)*
- *GearCalc (MFD28/32 Gen2 only)*
- *FreqIn1 (MFD28/32 Gen2 only)*
- *MathChannel1 (MFD28/32 Gen2 only)*
- *MathChannel2 (MFD28/32 Gen2 only)*
- *MathChannel3 (MFD28/32 Gen2 only)*
- *MathChannel4 (MFD28/32 Gen2 only)*
- *MathChannel5 (MFD28/32 Gen2 only)*
- *MathChannel6 (MFD28/32 Gen2 only)*
- *MathChannel7 (MFD28/32 Gen2 only)*
- *MathChannel8 (MFD28/32 Gen2 only)*
- *Usertable1 (MFD28/32 Gen2 only)*
- *Usertable2 (MFD28/32 Gen2 only)*
- *Usertable3 (MFD28/32 Gen2 only)*
- *Usertable4 (MFD28/32 Gen2 only)*
- *Usertable5 (MFD28/32 Gen2 only)*
- *Usertable6 (MFD28/32 Gen2 only)*
- *Usertable7 (MFD28/32 Gen2 only)*
- *Usertable8 (MFD28/32 Gen2 only)*

The **fourth area** can be used to get a quick overview of the individual information about the *sensors*. Simply select the desired information and compare it directly.

In the **fifth and last area** you have the possibility to activate the *enhanced mode* by a slider. In the *enhanced mode* (chapter 8.2.2) you also have the possibility to set the *min* and *max warning values* for each *sensor* in the *TRI Editor*. To do this, please click on the corresponding *sensor* to open the popup for editing.

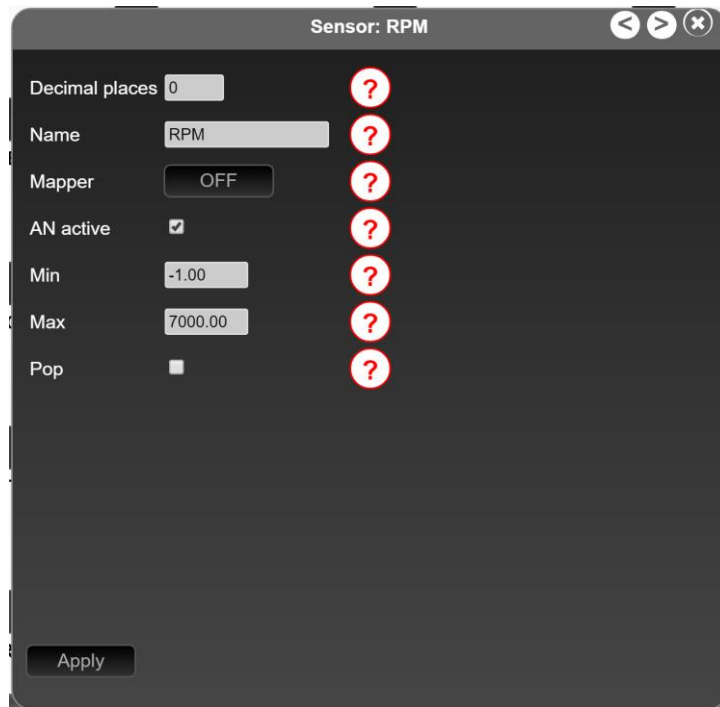

Figure 30: Popup to edit the sensor in normal mode

In addition to the *min* and *max* warning values, you can also assign/change the names of your *sensors* (maximum 15 characters – no special characters) and switch popups for the *warning values* on and off. After you have changed/renamed the sensor, you have to confirm the changes with the *Apply button*. Once you have adjusted all *sensors* according to your wishes, you can save the changes locally to your computer via the *safe to file* button on the button and later upload them to your data display via WLAN via the *upload section* in the *oDSS*.

### 8.2.2 enhanced mode

If you switch on the *enhanced mode*, you get even more possibilities to configure your sensors and the associated Can Bus details and reference sensors.

With the reference sensor, you can set the min or max warning even better. For example, if you set a min warning of 1.1 bar for the oil pressure, you will constantly get a pop-up even when idling. If you now specify the sensor speed as *RefSensor* with a *RefValue* of 3000, the min oil pressure warning will only be activated if the oil pressure is less than 1.5 bar, but only as long as the *sensor* speed has a value above 3000.

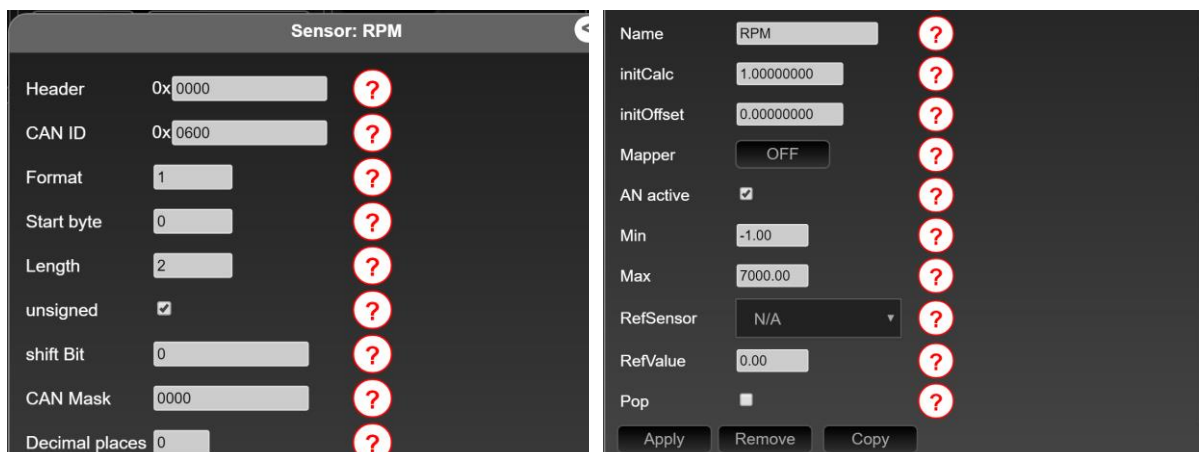

Figure 31: Popup for editing the sensor in enhanced mode

In addition, you now also have *the remove and copy* buttons to choose from with which you can delete and copy can addresses and sensors. This function is especially handy when creating your own *TRI files*.

Please note that the pages point to the *sensor* location, so if you delete *sensors*, you will most likely need to readjust your pages

### 8.2.3 Setup of analog inputs via DSS

The *analog inputs* can be set up both via the DSS and via the *oDSS* (chapter 6.1.7).

If your TRI file does not yet have a sensor for an *analog input*, you can add it to your *TRI file* by selecting the corresponding AIN(s), scrolling down and pressing *Apply*. Now you must activate the enhanced mode in the upper right corner. You can change the name, adjust the attenuation, choose the type of mapper and of course activate the *analog input*.



Figure 32: Adding AINs

The mapper can be set to three different options:

- *OFF* (shows the 10bit ADC value: 0-1023)
- *MAP*
- *NTC*

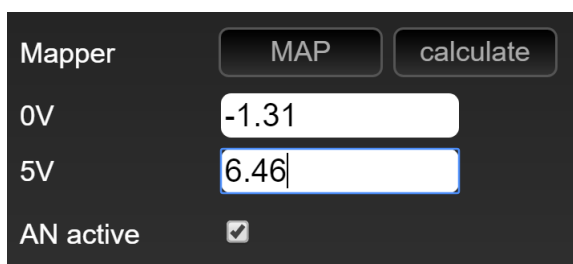

Figure 33: MAP

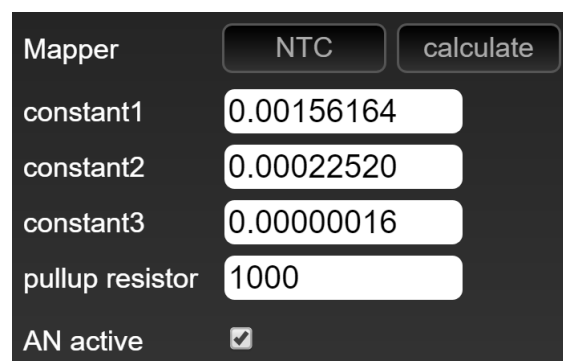

Figure 34: NTC

If set to *OFF*, no characteristic curve is activated and a value of 0-1023 is output.

If set to *MAP*, the values for zero and five volts can be entered. If the data sheet of your sensor only provides values for 0.5 and 4.5 volts, you can open the calculation tool by clicking on *calculate* to calculate the corresponding values for zero and five volts.

If set to *NTC*, you can enter the three constants of your NTC sensor as well as the pull-up resistance. If you only have three data points, the calculation tool will help you with one click on *calculate*.

While you're at it, you can directly assign the *min* and *max* values of your *sensor* (chapter 8.1).

If the value of your *analog input* fidgets too much, you have the option of activating the attenuation. In the case of the *analog inputs*, this is hidden behind the point *Length*.



Figure 35: Attenuation of an analog input

If a 0 is entered here, the value is not damped. The maximum attenuation has a value of 249. A good starting value for damping is 210.

After you have adjusted all values, you can cache your setup by clicking on *Apply* and then save it locally on your PC with the *safe to file* button before uploading the modified *TRI* to your data display via Wi-Fi.

### 8.3 Log Viewer

In the *Log Viewer*, the logs generated with the *oDSS* can be viewed and imported. The logging function is a licensed option and is described in Chapter 6.2

If you have recorded a log with the *oDSS* and your MFD15 Gen2, you can save it in a cloudservice or locally and transfer it to your computer.

To view a log, you have to navigate to the *Log Viewer* tab and import the *log* stored locally on your computer into the *DSS* via *load from file*.

To open a log, click on it and open the *log* via the *load* button.

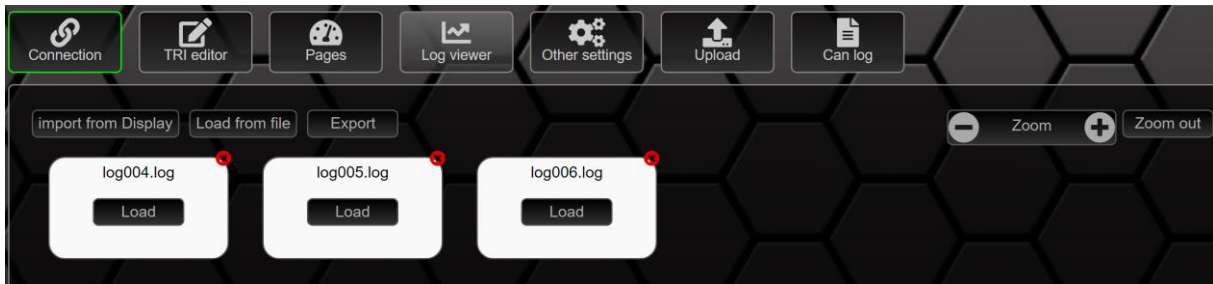

Figure 36: Overview Log Viewer

Once you have opened a *log*, the diagram will be displayed on the left half of your screen and the available sensors on the right half. Now you can select the *sensors* relevant to you from this list by clicking on them and display them in the diagram. With the mouse cursor you can stretch the relevant areas by clicking and pressing and zoom in and out via the zoom function in the upper right corner of the *log*.

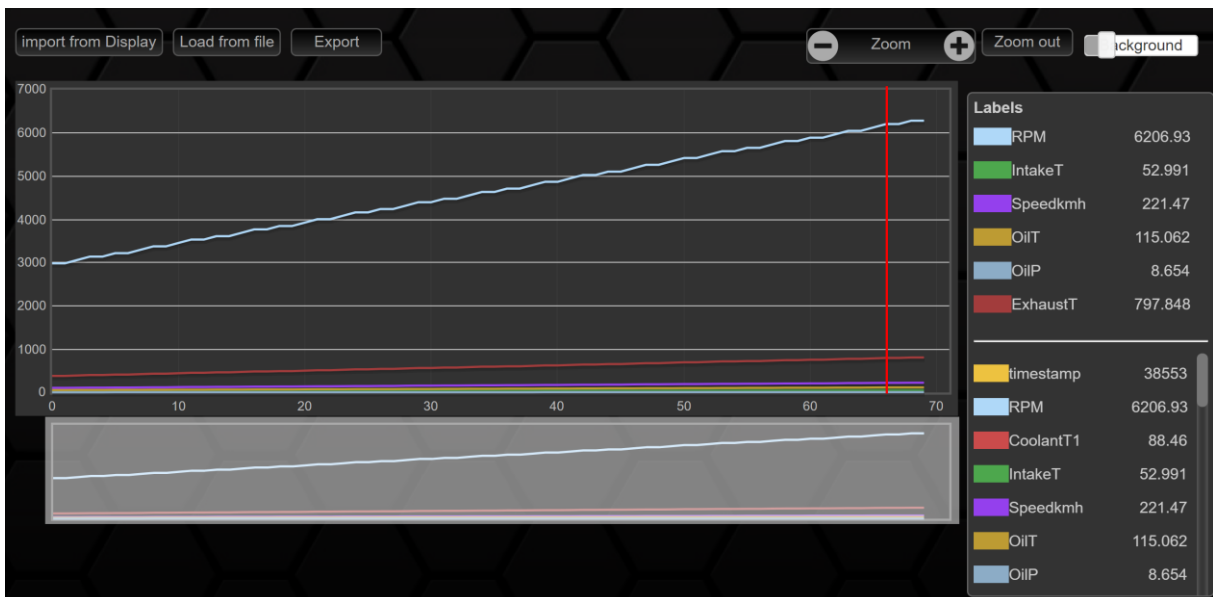

Figure 37: open log

## 9 FAQ

This chapter collects recurring questions and offers solutions.

### 9.1 Display does not turn on

If your display does not turn on, there is probably a problem with the power supply, and you need to check your 12V wiring in the vehicle again.

If you look into the housing at the back of the display between the plugs, you will see a green LED light up when the voltage is applied.

If the LED lights up but your display still does not start, it must be sent to our service for further diagnosis. Please contact [info@canchecked.de](mailto:info@canchecked.de) by email before submitting to describe your problem and discuss further steps.

### 9.2 I don't get any data

If your display cannot establish a successful Can Bus connection, the Can Bus icon in the upper right corner of the status bar will be red. Please make sure that Can Bus Speed, Termination and TRI File are correct.

If you use our OBD cable, you can still check the pinout for correctness. The yellow wire should go to connector C pin 8 and the white wire to connector C pin 7. On the OBD socket are Can High on pin 6 and Can Low on pin 14. With a continuity tester, the passage can be checked from the OBD connector to plug C and a fault at this point can be diagnosed or ruled out.

If no improvement occurs, please contact [info@canchecked.de](mailto:info@canchecked.de) with a complete description of the error.

### 9.3 Gear indicator does not work

The gear indicator calculates the gear from engine speed and speed. If your gear indicator does not work, this can have various causes:

- The *sensors* RPM and Speed are incorrectly assigned on the page in oDSS.
- The gear ratios for each gear are entered incorrectly in the oDSS.
- The RPM and Speed sensors provide erroneous values.

### 9.4 My Performance Meter runs permanently

If the *Performance Meter* runs continuously, even when stationary, the *widget* is assigned the wrong *sensor*. To assign the correct sensor, you have to edit the corresponding page in oDSS and assign the correct sensor.

### 9.5 How do I change my startup screen?

It is possible to change the start image. To change it, you have to upload a 24 bit .bmp file with a size of 128x 128pixels via the *upload section* via the oDSS. The successful upload is acknowledged in the progress bar with *success*.

With the next reboot of your data display, you will now see the new start image. MS-Paint has proven itself for scaling and converting your image file.

### 9.6 How can I fine-tune a Can Bus sensor?

The speedometer in your vehicle shows you a speed of 100 km/h, but only 95 km/h is shown on your display. On the display we show you the true value and not an embellished (the same applies to the coolant temperature) value.

However, if you want your display to show the same value as your speedometer, you can use the multiplier (see chapter 8.1). If you want your display to show 100 km/h instead of 95 km/h, you must adjust the multiplier to 1,053 (100/95).

$$\frac{\textit{value should}}{\textit{value is}} = \textit{multiplier}$$

Of course, the same applies to Can Bus *sensors* such as power or torque.

### 9.7 How can I perform a reset

If your device is no longer accessible or frozen, you can try to get it back to life by resetting. To perform the reset, you must hold down the right button before turning on the ignition.

Now your display does not start as usual but asks if you want to perform a reset. With the left button you confirm the reset, with the right button you cancel the process. If you only want to get access to the oDSS , you can activate the hotspot here by pressing both buttons for a long time and add new firmware to your display from the oDSS.