

# **INSTRUCTION MANUAL**

## **CHEST FREEZERS**

This manual contains important information regarding your unit. Please read this manual thoroughly prior to equipment set-up, operation and maintenance. Failure to comply with regular maintenance guidelines outlined in this manual may void the warranty.

## WARNINGS

- Plug into a grounded 3-prong outlet, do not remove grounding prong, do not use an adapter, and do not use an extension cord
- It is recommended that a separate circuit, serving only your refrigerator be provided. Use receptacles that cannot be turned off by a switch or pull chain
- Never clean refrigerator parts with flammable fluids. These fumes can create a fire hazard or explosion. And do not store or use gasoline or other flammable vapors and liquids in the vicinity of this or any other appliance. The fumes can create a fire hazard or explosion.
- Before proceeding with cleaning and maintenance operations, make sure the power line of the unit is disconnected
- Do not connect or disconnect the electric plug when your hands are wet
- Unplug the refrigerator or disconnect power before cleaning or servicing. Failure to do so can result in electrical shock or death.
- Do not attempt to repair or replace any part of your refrigerator unless it is specifically recommended in this manual. All other servicing should be referred to a qualified technician.
- Use two or more people to move and install refrigerator. Failure to do so can result in back or other injury.
- To ensure proper ventilation for your refrigerator, the front of the unit must be completely unobstructed. Choose a well-ventilated area with temperatures above 60°F (16°C) and below 90°F (32°C). This unit must be installed in an area protected from the element, such as wind, rain, water spray or drips.
- The refrigerator should not be located next to ovens, grills or other sources of high heat
- The refrigerator must be installed with all electrical connections in accordance with state and local codes. A standard electrical supply (115 V AC only, 60 Hz), properly grounded in accordance with the National Electrical Code and local codes and ordinances is required.
- Do not kink or pinch the power supply cord of refrigerator
- The fuse (or circuit breaker) size should be 15 amperes
- It is important for the refrigerator to be leveled in order to work properly. You may need to make several adjustments to level it.
- Never allow children to operate, play with or crawl inside the refrigerator
- Although the unit has been tested at the factory, due to long-term transit and storage, the first batch of cubes must be discarded
- Do not use solvent-based cleaning agents or abrasives on the interior. These cleaners may damage or discolor the interior
- Do not use this apparatus for other than its intended purpose

## FEATURES:

1. Lid
2. Handle
3. Thermostat Control
4. Power Light
5. Compressor Light

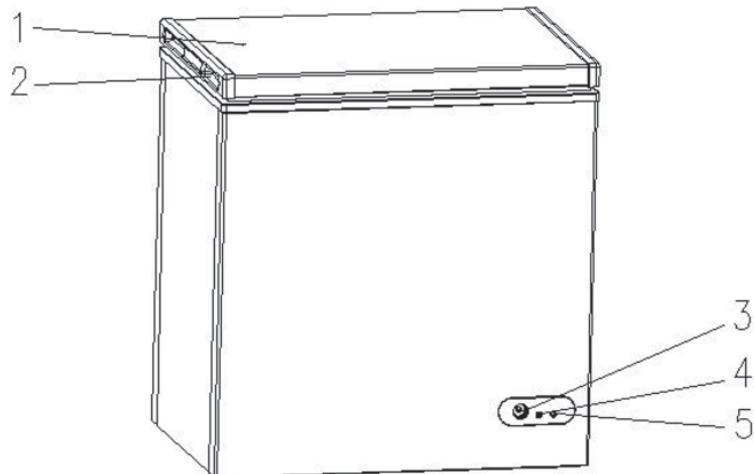

## TO INSTALL:

1. Remove unit from box and make sure all plastic, tape and packing materials are removed.
2. Place the unit on a flat, secure surface with at least 6" of open space around all sides.
3. Place the unit in an area that is not in direct sunlight or any other sources of heat.
4. Before plugging into your unit, let it sit for 2 hours.
5. Check to make sure the outlet of the correct voltage for this item (120V) is near. Do not use an extension cord, this item must be plugged directly into an outlet.

## TO USE:

### Setting the temperature control

1. To control the internal temperature, adjust the control dials according to the ambient temperature or purpose of use.
2. The first time you turn the unit on, set the temperature control to "7".
3. The range of the temperature control is from position "1" the warmest to "7" the coldest in the freezer section. After 24 to 48 hours, adjust the temperature control to the setting that best suits your needs. The setting of "4" should be correct for home or office refrigerator use.



**NOTE:** If the unit is unplugged, lost power or turned off, you must wait 3-5 minutes before restarting. If you try to restart the unit too early, it will not start. Turning the temperature control to "OFF" position stops the cooling cycle but does not shut off the power to the freezer. If you choose to change the thermostat setting, adjust thermostat control by one numerical increment at a time. Allow several hours for temperature to stabilize between adjustments. Large amounts of food will lower the cooling efficiency of the appliance.

### Defrosting the freezer

For the most efficient operation and minimum energy consumption, defrost the freezer when the frost on the freezer walls is excessive or  $\frac{1}{4}$  to  $\frac{1}{2}$  inch thick. Choose a time when the stock of frozen food is low. Do not use boiling water because it may damage the plastic parts. In addition, never use a sharp or metallic instrument to remove frost as it may damage the cooling coils and will void the warranty. We recommend using the plastic scraper provided with your unit.

1. Remove the frozen food from the freezer and place it in a cooler to protect the food.
2. Turn the thermostat knob to "OFF".
3. Unplug the freezer. The "POWER ON INDICATOR" light should be OFF.
4. During defrosting, the ice melts into the cabinet.
5. Remove the drain plug on the inside floor of the freezer by pulling straight out.
6. Place a shallow pan outside drain outlet. The defrost water will drain out.
7. Check the pan occasionally so the water does not overflow.
8. Clean the interior of the freezer.
9. Replace the plug on the inside floor.
10. Reconnect electrical connection. The "POWER ON INDICATOR" light should be ON.
11. Reset the thermostat to desired setting.
12. Allow the cabinet to cool for one hour.
13. Return food to the freezer.

Defrosting usually takes a few hours. Leaving the door open will help speed the process. Also, pouring warm water (not boiling) on the ice/frost will help speed melting. If you must use a scraper- please use caution - it is very easy to damage the freezer compartment and void your warranty.

### Freezer Compartment

- This compartment is designed for the long-term storage of frozen food. Storage time is up to three months.
- The storage life of frozen foods varies and the recommended storage time should not be exceeded. The instructions regarding the care of frozen foods should be followed when defrosting the freezer.
- Pre-packed commercially frozen food should be stored in accordance with the frozen foods manufacturer's instructions for a three star frozen food storage compartment or home freezer
- Place frozen food into the freezer as quickly as possible after purchase. If there are instructions on the packet, carefully follow these instructions regarding storage times
- The freezer door is susceptible to breaking due to excessive ice build up. Be sure to defrost when the ice reaches  $\frac{1}{4}$  to  $\frac{1}{2}$  inch thick.

A storage basket is provided for the organization of odd-shaped items. To reach other packages in the freezer, just slide the basket to one side, or lift it out

### **Freezing Fresh Foods**

- Proper use of the appliance, adequately packed food, correct temperature and taking into account hygienic precautions will substantially influence the quality of freezing the food or storing of the frozen foods
- This compartment is designed for the long-term storage of frozen food
- The storage life of frozen foods varies and the recommended storage time should not be exceeded
- Pre-packed commercially frozen food should be stored in accordance with the frozen foods manufacturer's instructions for a three star frozen food storage compartment or home freezer
- Place frozen food into the freezer as quickly as possible after purchase. If there are instructions on the packet, carefully follow these instructions regarding storage times.
- Carefully select food you intend to freeze, it should be of adequate quality and suitable for freezing
- Use correct packaging and wrap it tight
- The packaging should be airtight and shouldn't leak since this could cause substantial vitamin loss and dehydration of foods
- Foils and bags should be soft enough to tightly wrap around the foods
- When preparing foods to be frozen, consider sanitary precautions
- Mark packages with following data: kind and amount of foods and the date of loading
- It is most important that the food is frozen as quickly as possible
- If the loading amount is too large, the quality of freezing is reduced which affects the quality of frozen foods

### **Cleaning Your Freezer**

- Upon installation of your new appliance, it is recommended that it be cleaned thoroughly
- Turn the temperature control to "OFF", unplug the freezer, remove the food and storage basket
- Wash the inside with a damp warm cloth containing a water and baking soda solution. The solution should be about 2 tablespoons of baking soda to a quart of water.
- Wash the storage basket with a mild detergent solution
- Be sure to keep the door gasket (seal) clean to keep the unit running efficiently
- The outside of the freezer should be cleaned with mild detergent and warm water
- Dry the interior and exterior with a soft cloth
- It is recommended that the unit be cleaned each time it is defrosted to help keep the unit odor free and running efficiently

### **Vacation Time**

- Remove all the food
- Unplug the freezer
- Clean the freezer
- Leave the door open slightly to avoid possible formation of condensation, mold, or odors
- Use extreme caution in the case of children. The unit should not be accessible to child's' play
- Short vacations: Leave the freezer operating during vacations of less than three weeks
- Long vacations: If the appliance will not be used for several months, remove all food and unplug the power cord. Clean and dry the interior thoroughly. To prevent odor and mold growth, leave the door open slightly: blocking it open if necessary or have the door removed.

### **Moving the Freezer**

- Remove all the food
- Securely tape down all loose items inside your freezer
- Remove the rollers to prevent damage
- Tape the doors shut
- Be sure the freezer stays in the upright position during transportation

### **Energy Saving Tips**

- The freezer should be located in the coolest area of the room, away from heat producing appliances or heating ducts, and out of the direct sunlight
- Let hot foods cool to room temperature before placing in the freezer. Overloading the freezer forces the compressor to run longer. Foods that freeze too slowly may lose quality, or spoil.
- Be sure to wrap foods properly, and wipe containers dry before placing them in the freezer. This cuts down on frost build-up inside the freezer.

- Freezer storage bin should not be lined with aluminum foil, wax paper, or paper toweling. Liners interfere with cold air circulation, making the freezer less efficient.
- Organize and label food to reduce door openings and extended searches. Remove as many items as needed at one time, and close the door as soon as possible

## TROUBLESHOOTING

Problem	Possible Causes
Freezer does not operate	<ul style="list-style-type: none"> <li>-Not plugged in</li> <li>-The circuit breaker tripped or a blown fuse</li> <li>-The freezer temperature control is set at "0/OFF"</li> </ul>
Compressor turns on and off frequently	<ul style="list-style-type: none"> <li>-The room temperature is hotter than normal</li> <li>-A large amount of food has been added to the freezer</li> <li>-The door is open too often</li> <li>-The door is not closed completely</li> <li>-The temperature control is not set correctly</li> <li>-The door gasket does not seal properly</li> <li>-The freezer does not have the correct clearances</li> <li>-The freezer has recently been disconnected for a period of time. Four hours are required for the freezer to cool down completely.</li> </ul>
Temperature inside the freezer is too warm	<ul style="list-style-type: none"> <li>-Temperature control is set too warm. Turn the control to a cooler setting and allow several hours for the temperature to stabilize.</li> <li>-Door is kept open too long or is opened too frequently. Warm air enters the freezer every time the door is opened. Open the door less often.</li> <li>-The door is not closed completely</li> <li>-The door gasket does not seal properly</li> <li>-A large amount of warm or hot food might have been stored recently. Wait until the freezer has had a chance to reach its selected temperature.</li> <li>-The freezer has recently been disconnected for a period of time. Four hours are required for the freezer to cool down completely.</li> </ul>
Temperature inside the freezer is too cold	<ul style="list-style-type: none"> <li>-Temperature control is set too cold. Turn the control to a warmer setting and allow several hours for the temperature to stabilize.</li> <li>-Fast Freeze switch is turned on. This causes continuous running of the compressor and bypasses the temperature control.</li> </ul>
Temperature of external freezer surface is warm	<ul style="list-style-type: none"> <li>-The exterior freezer walls can be as much as 30°F warmer than room temperature.</li> <li>-This is normal while the compressor works to transfer heat from inside the freezer cabinet.</li> </ul>
Popping or cracking sound when compressor comes on	<ul style="list-style-type: none"> <li>-Metal parts undergo expansion and contraction, as in hot water pipes. This is normal. Sound will level off or disappear as freezer continues to run.</li> </ul>
Bubbling or gurgling sound, like water boiling	<ul style="list-style-type: none"> <li>-Refrigerant (used to cool freezer) is circulating throughout the system. This is normal.</li> </ul>
Freezer is vibrating	<ul style="list-style-type: none"> <li>-Check to assure that the freezer is on a level surface</li> <li>-Floor is uneven or weak. Freezer rocks on the floor when it is moved slightly. Be sure floor can adequately support freezer. Level the freezer by putting wood or metal shims under part of the freezer.</li> <li>-The freezer is touching the wall. Re-level the freezer and move it from the wall.</li> </ul>
Moisture forms on inside freezer walls	<ul style="list-style-type: none"> <li>-Weather is hot and humid, which increases internal rate of frost build-up. This is normal.</li> <li>-Door is slightly open</li> <li>-Door is kept open too long, or is opened too frequently. Open the door less often.</li> <li>-The door is not sealed properly</li> </ul>
Moisture forms on outside of freezer	<ul style="list-style-type: none"> <li>-Door is slightly open, causing cold air from inside the freezer to meet warm moist air from outside</li> </ul>
The door will not close properly	<ul style="list-style-type: none"> <li>-The freezer is not on a level surface</li> <li>-The gasket is dirty</li> <li>-The storage basket is out of position</li> </ul>

# Wiring Diagram for the Chest Freezers

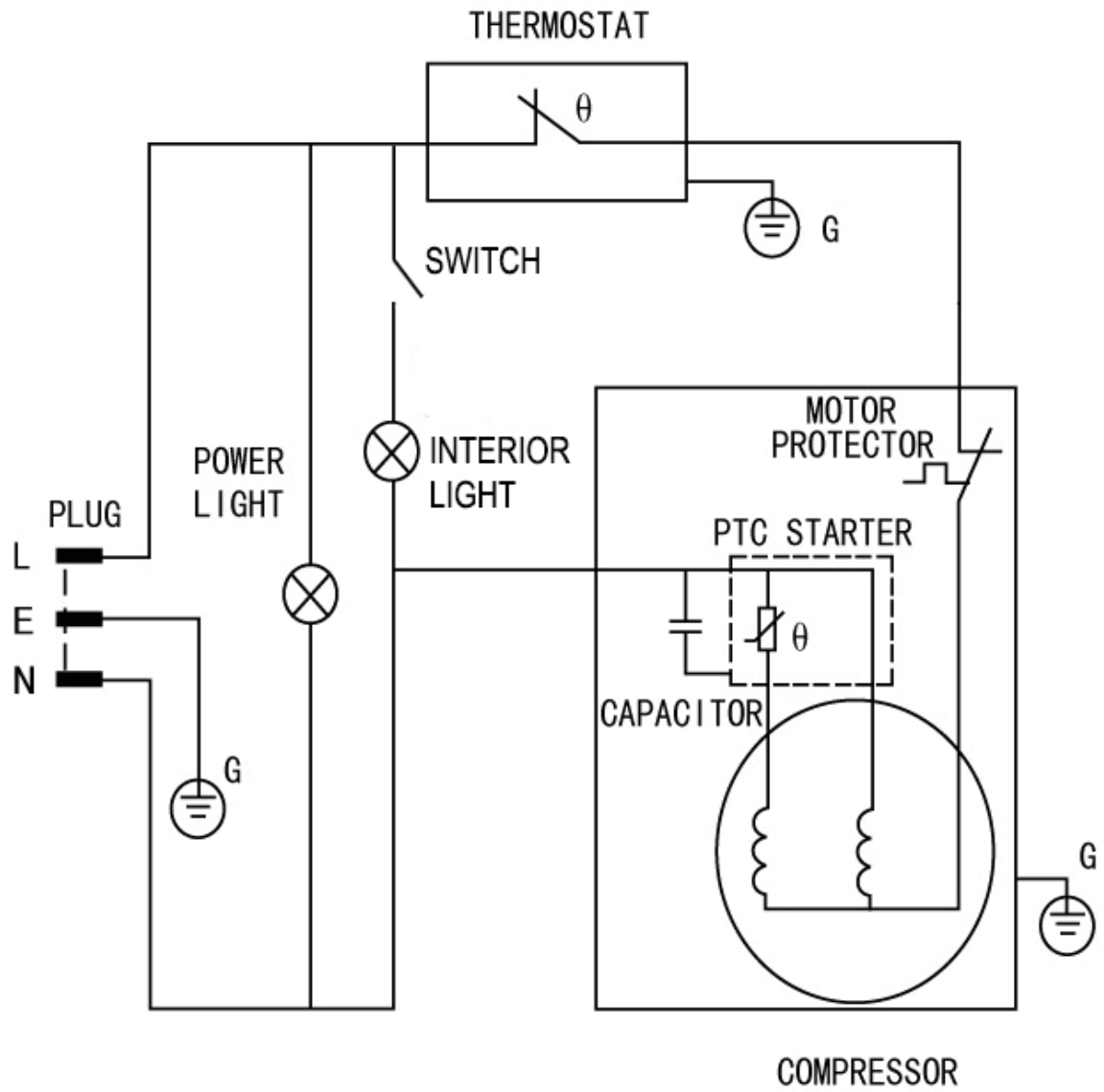

### Parts Diagram for the Chest Freezers

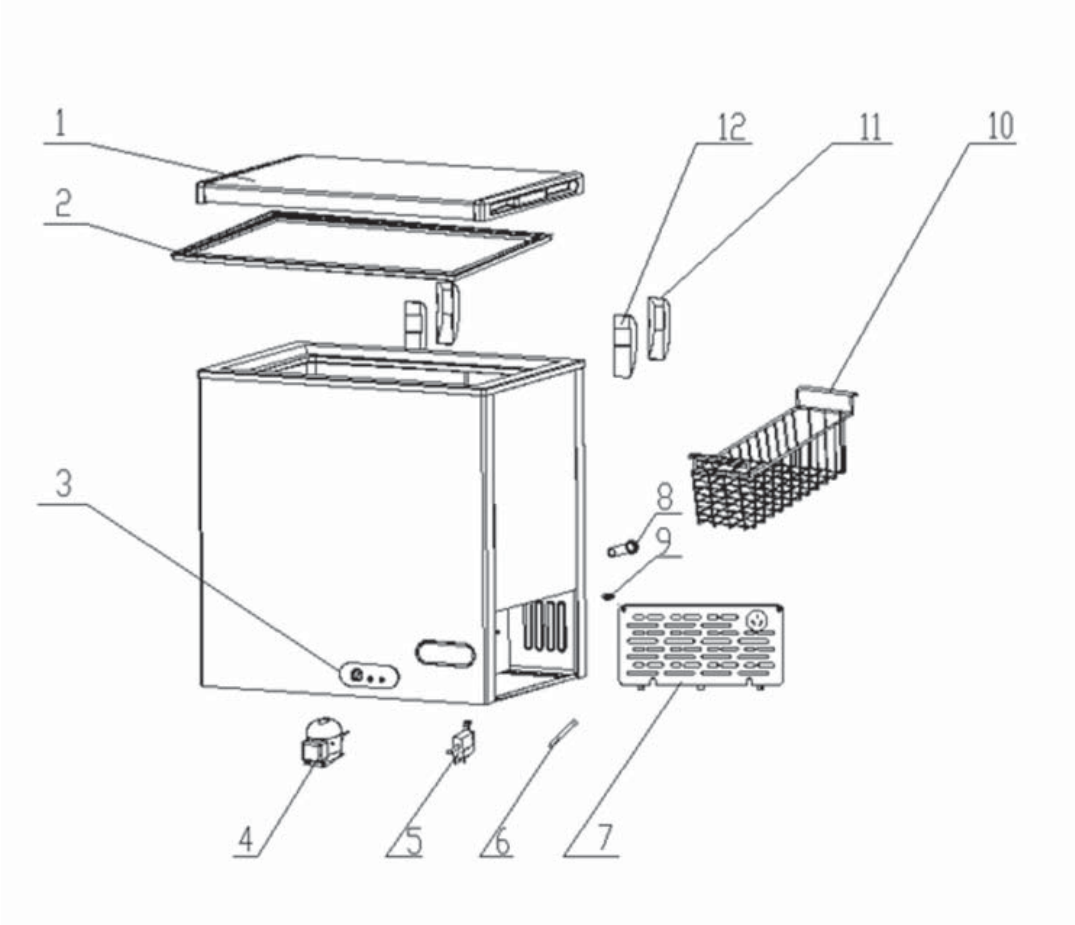

Drawing Number	Part Description
1	Door w/gasket
2	Door gasket
3	Control panel
4	Compressor
5	Thermostat
6	Filter
7	Compressor Cover
8	Outer drain plug
9	Inner drain plug
10	Basket
11	Hinge cover
12	Door hinge

# ACE Equipment One Year Limited Warranty

ACE warrants its equipment against defects in materials and workmanship, subject to the following conditions:

ACE Equipment is warranted for one year, effective from the date of purchase by the original owner. A copy of the original receipt or other proof of purchase is required to obtain warranty coverage. This warranty applies to the original owner only, and is not assignable.

Should any product fail to function in its intended manner under normal use within the limits defined in this warranty, at ACE's discretion, such product will be repaired, replaced with a refurbished unit, or replaced with a new unit by ACE, after defective unit has been inspected and defect has been confirmed. ACE does not assume any liability for extended delays in replacing any item beyond its control. This warranty does not apply to rubber and non-metallic synthetic parts that may need to be replaced due to normal usage, wear or lack of preventative maintenance.

This warranty covers products shipped into the 48 contiguous United States. Warranty coverage on products used outside the 48 contiguous United States, Hawaii, Alaska, Puerto Rico, and Canada, cover parts only.

The following conditions are not covered by warranty:

- Equipment failure relating to improper installation, improper utility connection or supply and problems due to improper ventilation.
- Equipment that has not properly been maintained, damage from improper cleaning, and water damage to controls.
- Equipment that has not been used in an appropriate manner, or has been subject to misuse, neglect, abuse, accident, alteration, negligence, damage during transit, delivery or installation, fire, flood, riot, or act of God.
- Equipment that has the model number or serial number removed or altered.
- Equipment on which the security seal has been broken.

If the equipment has been changed, altered, modified, or repaired without express written permission from ACE, then the manufacturer shall not be liable for any damages to any person or to any property, which may result from the use of this equipment thereafter.

This equipment is intended for commercial use only and this warranty is void if equipment is used in other than a commercial application.

For warranty and non-warranty related issues, technical support, please contact NSA at 1-877-672-7740. To purchase replacement parts and warranty registration visit [www.admiralcraft.com](http://www.admiralcraft.com). Please have your model number, serial number and proof of purchase ready. It is not necessary to contact the place where you originally purchased your product from.

“THE FOREGOING WARRANTY IS IN LIEU OF ANY AND ALL WARRANTIES EXPRESSED OR IMPLIED INCLUDING ANY IMPLIED WARRANTY OF MERCHANTABILITY OR FITNESS FOR PARTICULAR PURPOSES AND CONSTITUTES THE ENTIRE LIABILITY OF ACE. IN NO EVENT DOES THE LIMITED WARRANTY EXTEND BEYOND THE TERMS STATED HEREIN.”

## WARRANTY REGISTRATION CARD

MAIL CARD  
IMMEDIATELY



This card must be mailed immediately after installation date for warranty to be in effect.

National Service America • 230 Park Ave, 3<sup>rd</sup> Floor WEST • New York, NY • 10169

_____		_____	
(Name of Business)		(Dealer Purchased From)	
_____			
(Address)	(City)	(State)	(Zip Code)
_____		_____	
(Model Number)		(Serial Number)	

This is to inform that I, \_\_\_\_\_  
(Please print name of individual who owns business)

have had the above installed in my place of business \_\_\_\_\_  
(Date of Purchase)

_____	_____	_____
(Contact Phone Number)	(Contact E-mail)	(Signature of Individual Who Owns Business)