

SALAD PREP TABLE

TSP72

3-Door / Regular Top











TECHNICAL SPECIFICATIONS

| | |
|-----------------------|-----------------|
| Voltage/Frequency | 115V/60Hz |
| Refrigerant | R290 |
| Type of Defrost | Automatic |
| Interior Material | Stainless Steel |
| Exterior Material | Stainless Steel |
| Temperature Range °F | 33 ~ 41°F |
| Compressor Power (HP) | 1/3 |
| Nema Config. | NEMA5-15P |



PRODUCT FEATURES

-  The compressor is mounted in the back and placed in the coolest possible area; this makes it easily accessible for servicing.
-  Digital temperature controls with LED display for precise adjustment and automatic defrosting system.
-  Temperatures in the cabinet range from 33 to 41 degrees Fahrenheit
-  Higher Resistance to dust, high quality condenser.
-  R290 Natural Refrigerant promotes faster cool down and efficient energy consumption.
-  Self-closing doors at 60° with stay open feature.
-  Stainless steel interior & exterior, sealed interior floors, and rounded cabinet corners for easy cleaning.
-  6" deep 1/6 plastic plan included.
-  High quality coated stainless adjustable shelves prevent peel and rust.



HIGH QUALITY
STAINLESS STEEL &
ROBUST DESIGN

DETAILS & SPECIFICATIONS

SALAD PREP TABLE TSP72

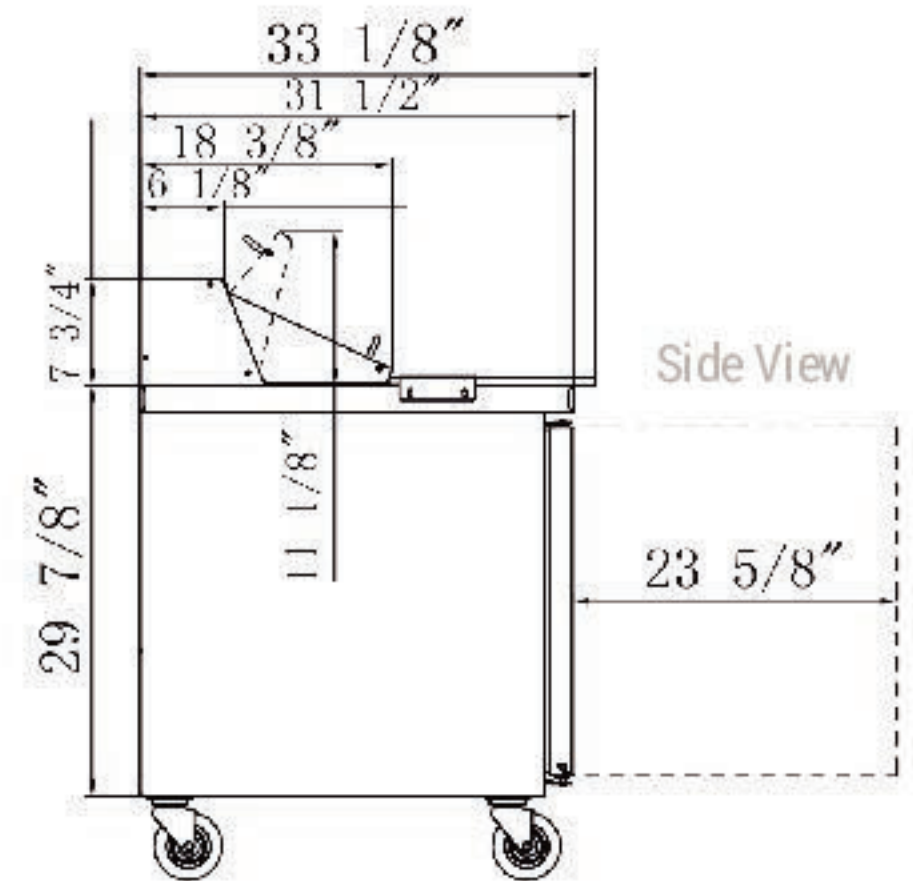
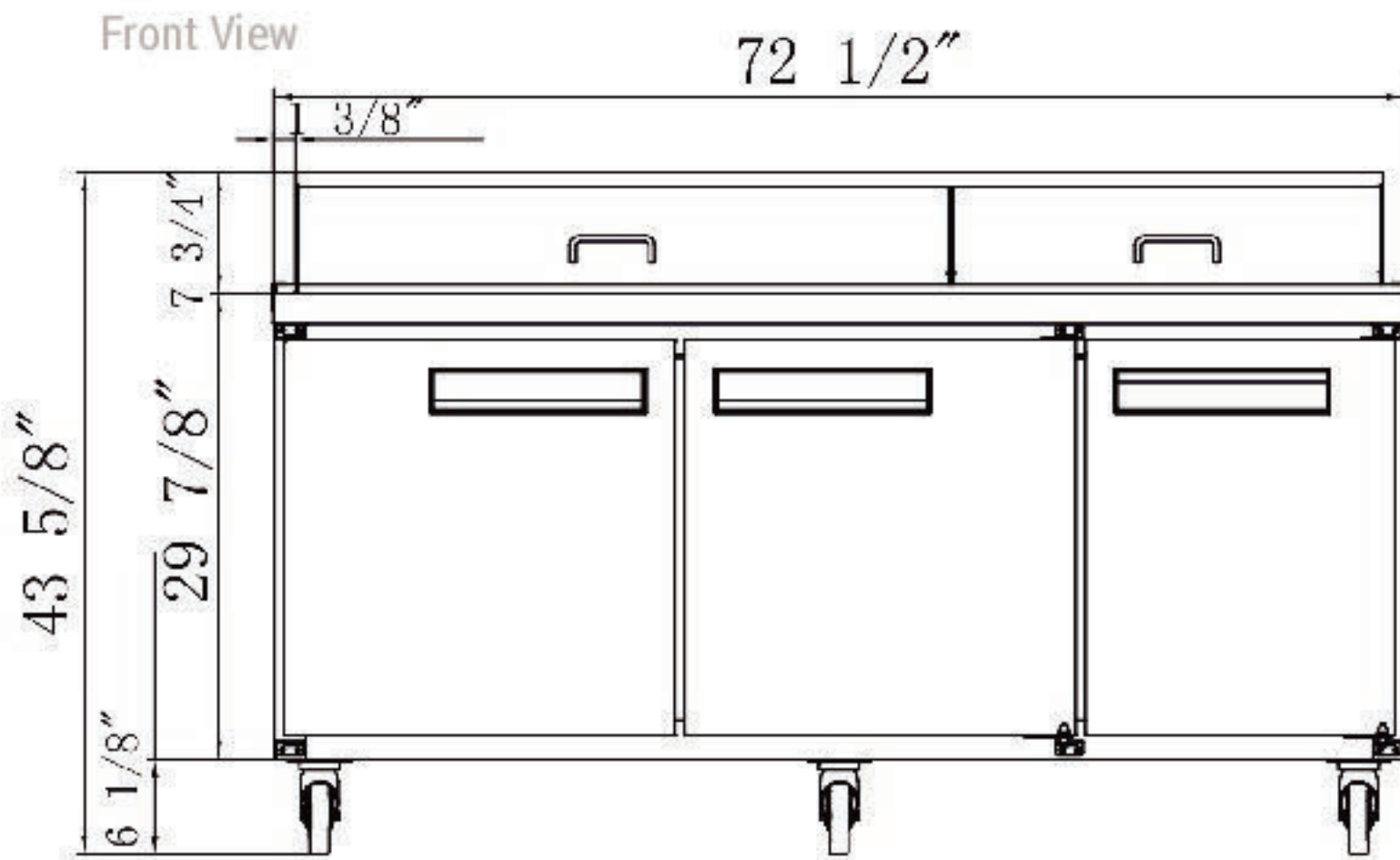

1/6 PAN COUNT: 18

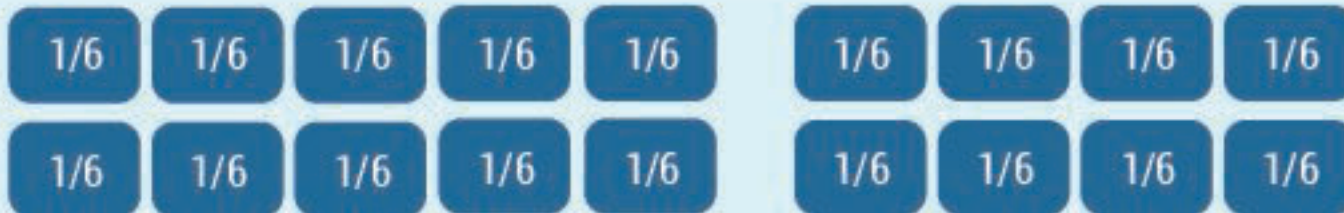

| | |
|---------------------------|--------------|
| Cutting Board Size | 72 x 14.5 |
| Rated Voltage | 115V |
| Rated Frequency | 60Hz |
| Total Input Power | 380W |
| Total Current | 3.4A |
| Total Capacity | 17.58 cu ft |
| Climatic Category | 4-5 |
| Protection Type | I |
| Design Pressure High Side | 300 PSIG |
| Design Pressure Low Side | 150 PSIG |
| Insulation Blowing Gas | C-Pentane |
| Refrigerant | R290/4.41 oz |

| MODEL | EXTERNAL DIMENSION WXDXH (INCHES) | PACKAGING DIMENSION WXDXH (INCHES) | PRODUCT NET WEIGHT | # OF SHELVES | 40HQ CONTAINER CERT. |
|-------|--------------------------------------|---------------------------------------|-----------------------|-----------------|-------------------------|
| TSP72 | 72 1/2 x 31 1/2 x 44 | 76 3/4 x 35 7/8 x 48 3/8 | 341 lbs | 3 | 26 |

