

SALAD PREP TABLE

TSP60

2-Door / Regular Top











TECHNICAL SPECIFICATIONS

Voltage/Frequency	115V/60Hz
Refrigerant	R290
Type of Defrost	Automatic
Interior Material	Stainless Steel
Exterior Material	Stainless Steel
Temperature Range °F	33 ~ 41°F
Compressor Power (HP)	1/5
Nema Config.	NEMA5-15P



PRODUCT FEATURES

-  The compressor is mounted in the back and placed in the coolest possible area; this makes it easily accessible for servicing.
-  Digital temperature controls with LED display for precise adjustment and automatic defrosting system.
-  Temperatures in the cabinet range from 33 to 41 degrees Fahrenheit
-  Higher Resistance to dust, high quality condenser.
-  R290 Natural Refrigerant promotes faster cool down and efficient energy consumption.
-  Self-closing doors at 60° with stay open
-  Stainless steel interior & exterior, sealed interior floors, and rounded cabinet corners for easy cleaning.
-  6" deep 1/6 plastic plan included.
-  High quality coated stainless adjustable shelves prevent peel and rust.



HIGH QUALITY
STAINLESS STEEL &
ROBUST DESIGN

DETAILS & SPECIFICATIONS

SALAD PREP TABLE TSP60

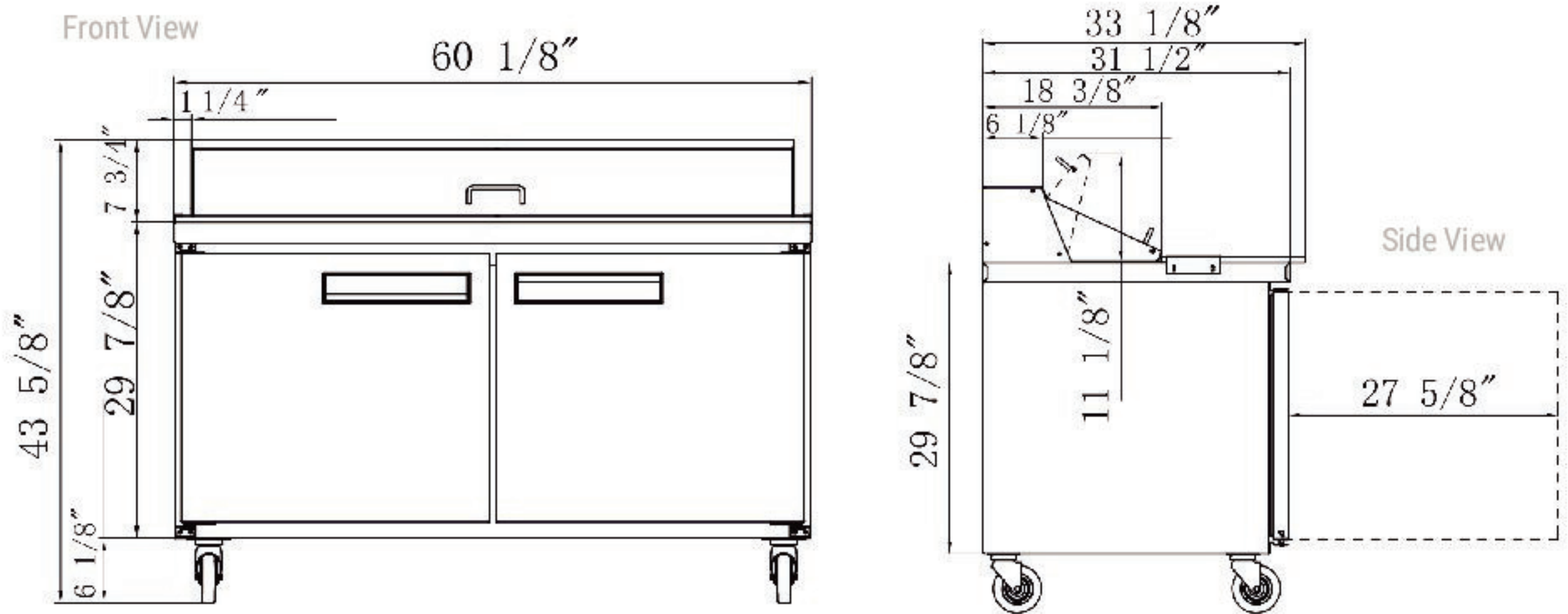

1/6 PAN COUNT: 16

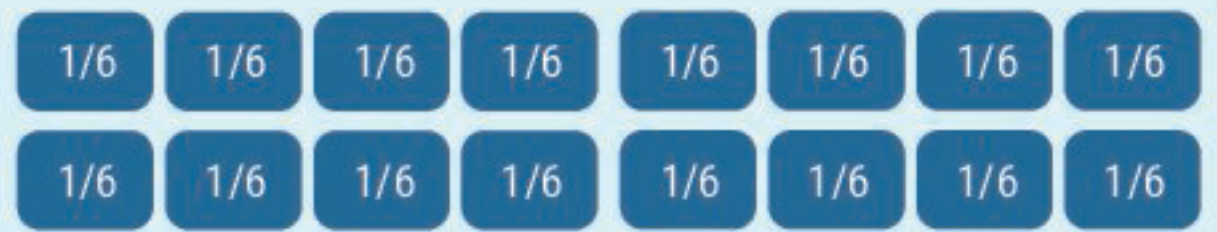

Cutting Board Size	60 x 14.5
Rated Voltage	115V
Rated Frequency	60Hz
Total Input Power	280W
Total Current	2.4A
Total Capacity	14.33 cu ft
Climatic Category	4-5
Protection Type	I
Design Pressure High Side	300 PSIG
Design Pressure Low Side	150 PSIG
Insulation Blowing Gas	C-Pentane
Refrigerant	R290/3.88 oz

MODEL	EXTERNAL DIMENSION	PACKAGING DIMENSION WXDXH (INCHES)	PRODUCT NET WEIGHT	# OF SHELVES	40HQ CONTAINER CERT.
TSP60	60 1/8 x 31 1/2 x	64 3/8 x 35 7/8 x 48 3/8	275 lbs	2	28



AutoQuotes



115/60/1
NEMA-5-15P