

SALAD PREP TABLE

TSP48

2-Door / Regular Top



TECHNICAL SPECIFICATIONS

Voltage/Frequency	115V/60Hz
Refrigerant	R290
Type of Defrost	Automatic
Interior Material	Stainless Steel
Exterior Material	Stainless Steel
Temperature Range °F	33 ~ 41°F
Compressor Power (HP)	1/5
Nema Config.	NEMA5-15P



PRODUCT FEATURES



The compressor is mounted in the back and placed in the coolest possible area; this makes it easily accessible for servicing.



Digital temperature controls with LED display for precise adjustment and automatic defrosting system.



Temperatures in the cabinet range from 33 to 41 degrees Fahrenheit



Higher Resistance to dust, high quality condenser.



R290 Natural Refrigerant promotes faster cool down and efficient energy consumption.



Self-closing doors at 60° with stay open feature.



Stainless steel interior & exterior, sealed interior floors, and rounded cabinet corners for easy cleaning.



6" deep 1/6 plastic plan included.



High quality coated stainless adjustable shelves prevent peel and rust.



HIGH QUALITY STAINLESS STEEL & ROBUST DESIGN

DETAILS & SPECIFICATIONS

SALAD PREP TABLE TSP48

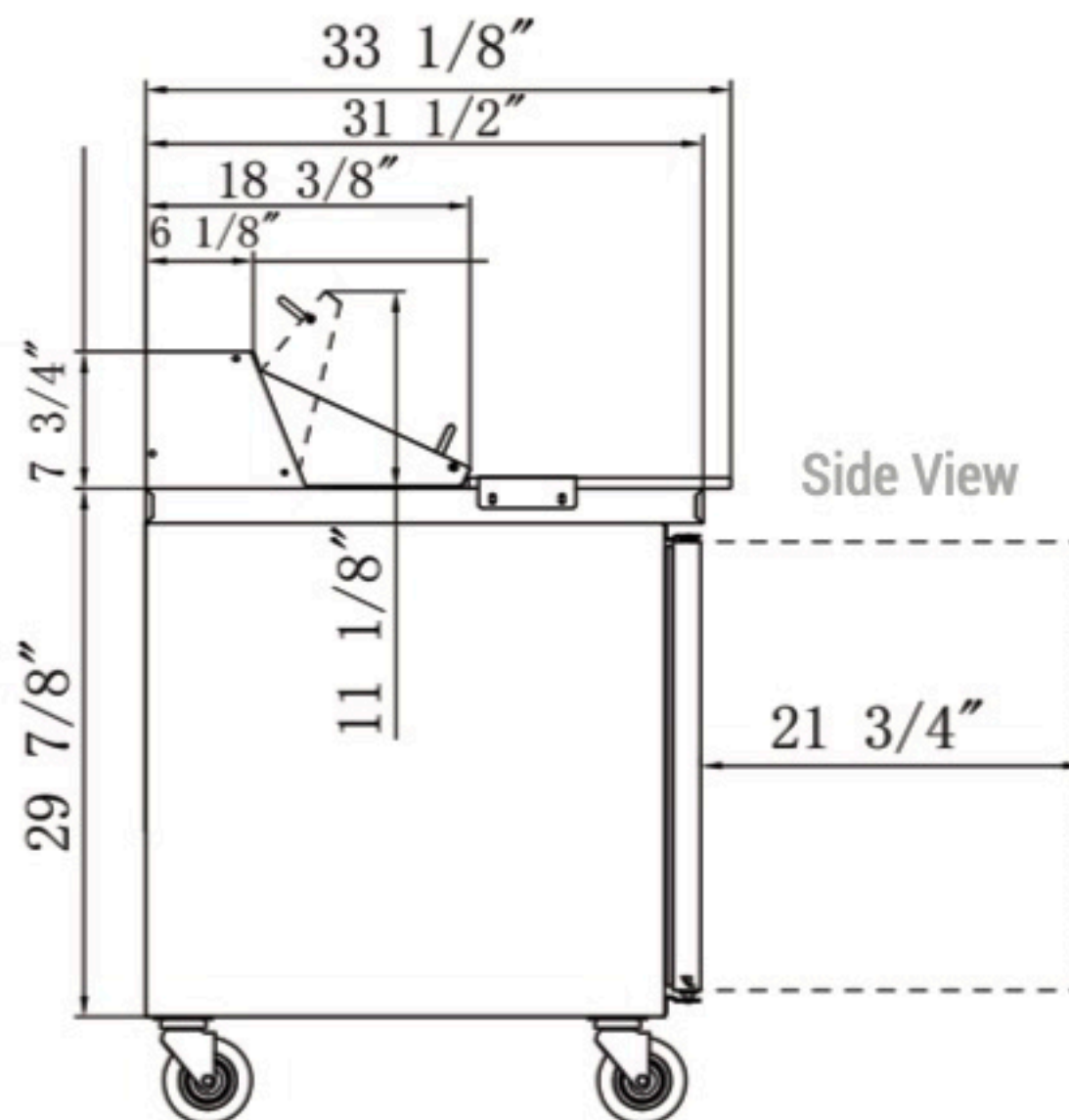
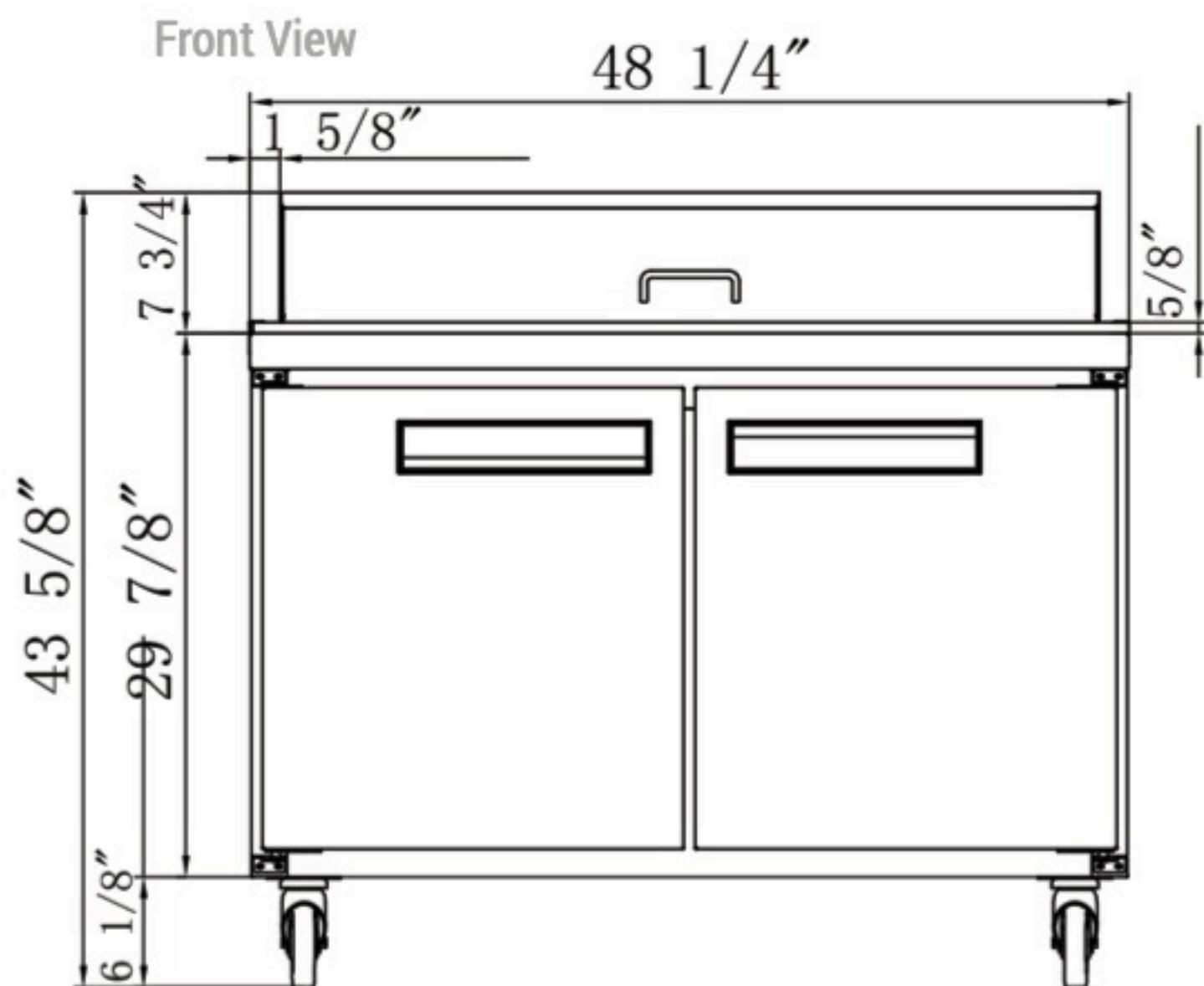

1/6 PAN COUNT: 12

Cutting Board Size	48 x 14.5
Rated Voltage	115V
Rated Frequency	60Hz
Total Input Power	280W
Total Current	2.4A
Total Capacity	11.47 cu ft
Climatic Category	4-5
Protection Type	I
Design Pressure High Side	300 PSIG
Design Pressure Low Side	150 PSIG
Insulation Blowing Gas	C-Pentane
Refrigerant	R290/3.17oz

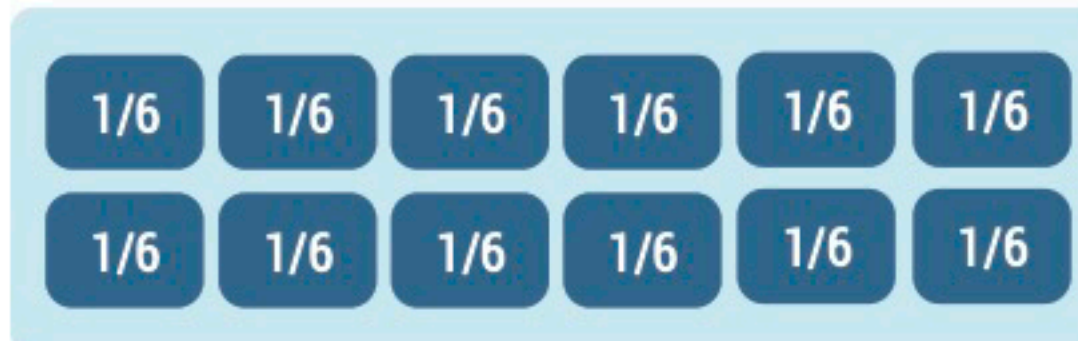

MODEL	EXTERNAL DIMENSION WXDXH (INCHES)	PACKAGING DIMENSION WXDXH (INCHES)	PRODUCT NET WEIGHT	# OF SHELVES	40HQ CONTAINER CERT.
TSP48	48 1/4 x 31 1/2 x 44	52 1/2 x 35 7/8 x 48 3/8	231 lbs	2	42



AutoQuotes



115/60/1
NEMA-5-15P