



DUKERS
Quality Commercial Refrigeration

Item # _____
Qty # _____
Model # _____
Project # _____



ELECTRIC FRYER

DCF10E 1 basket / 5L

High efficiency hotline, fast heating speed, uniform temperature, and energy saving.



Oil tank



Fryer Baskets



Knobs



PRODUCT DESCRIPTION

- ✦ The furnace body is made of stainless steel, and the oil basin is thickened stainless steel, resulting in a robust structure that boasts exceptional durability.
- 🛒 The whole machine design is novel, reasonable structure and convenient operation.
- 👤 Humanized cooking, easy and comfortable.
- 🧠 The handles are designed to remain cool to the touch, preventing burns and providing a comfortable grip. Additionally, the detachable parts make cleaning effortless.
- 🌡 The thermostat is designed with a power button switch to extend its lifespan, as well as automatic heating shut-off when the desired temperature is attained, and automatic restart when the temperature falls below the set point.



HIGH QUALITY STAINLESS STEEL & ROBUST DESIGN

FRYER MODEL	DIMENSION		
	Width	Depth	Height
DCF10E	12 3/4 in	17 1/8 in	12 1/4 in

* All measures are presented in Inches



Los Angeles | San Francisco | Dallas
Houston | Florida | Chicago | New Jersey

📞 1-800-931-8628

@ info@dukersusa.com

www.DukersUSA.com

DETAILS & SPECIFICATIONS

ELECTRIC FRYER DCF10E

Front View

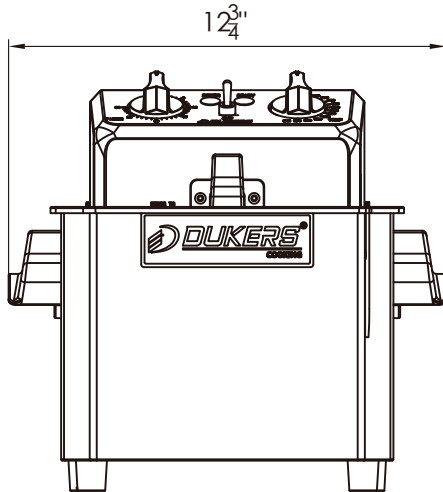

Side View

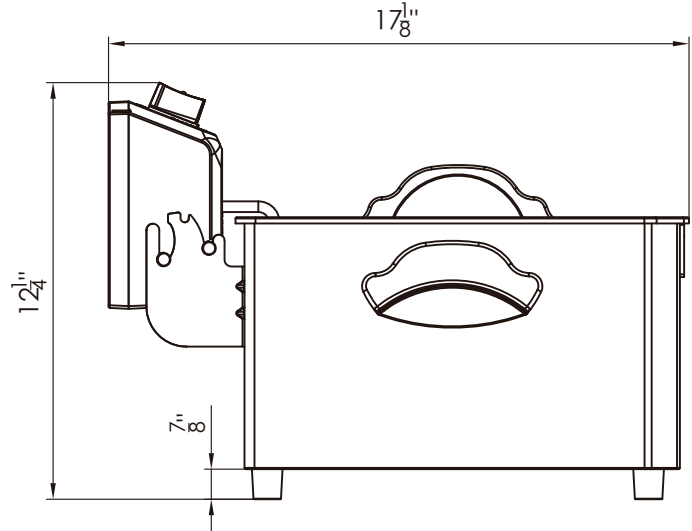

Top View

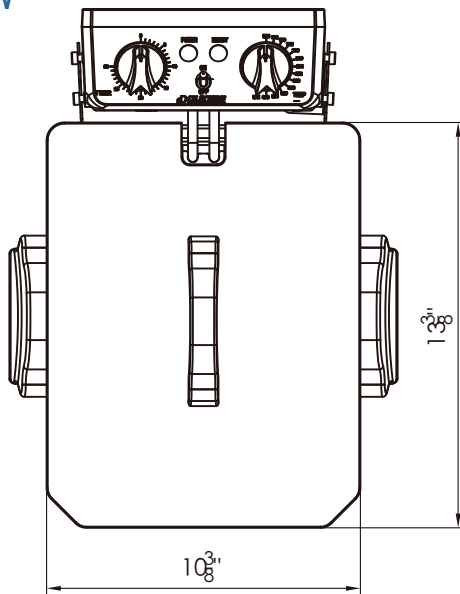

DCF10E

BASKET SIZE	9 1/2"x7 1/2"x4 3/5"
NUMBER OF BOXES	1
CYLINDER CAPACITY (L)	5L
VOLTAGE (V)	AC120
POWER (W)	1780W
NEMA (Plug Type)	5-15P / 5-20P
CURRENT (A)	14.83A

Model	Packaging Dimensions (inches)			Net Weight (lbs)	Ship Weight (lbs)
	W	D	H		
DCF10E	15 1/8"	20"	14 3/8"	12	14.8



Los Angeles | San Francisco | Dallas
Houston | Florida | Chicago | New Jersey

1-800-931-8628

@ info@dukersusa.com

www.DukersUSA.com