

ZBAR1-10V

WIRING INSTRUCTIONS & GUIDELINES

TECHNICAL OVERVIEW

Suitable for 1-10V loads, the ZBAR1-10V unit must be controlled with a Zano rotary controller. Up to 32 rotary controllers can be connected in parallel to one ZBAR1-10V. Please note that when dimming your lights with multiple rotary controllers the light levels are adjusted from the last level selected at that switch point. No need for screened cable, simply connect using any 2 core cable.

A COMBINATION OF ZANO ZBAR DIMMERS & CONTROLLERS MAY BE USED ON THE SAME CIRCUIT

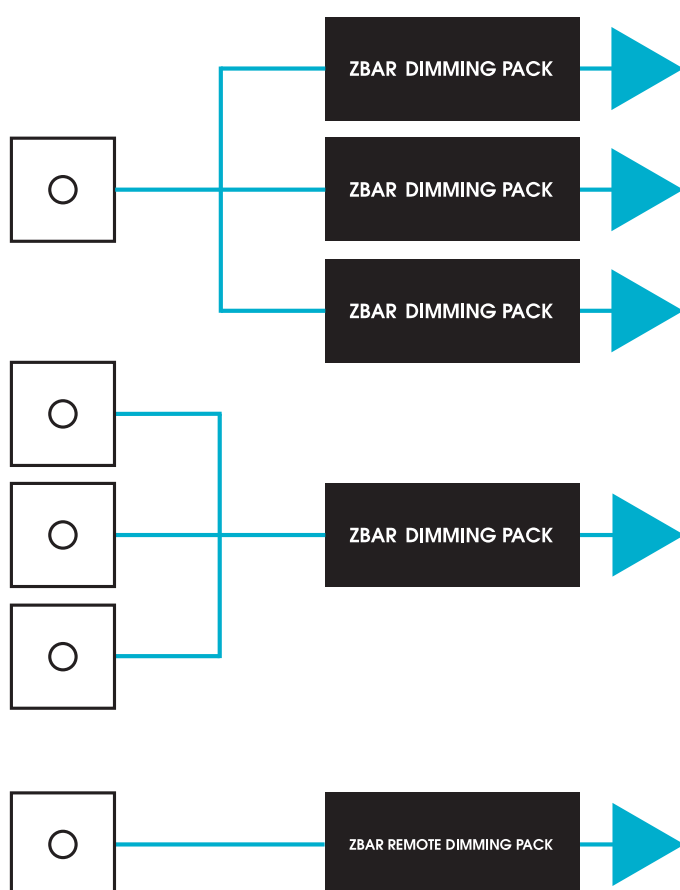

ZANO ROTARY CONTROLLER

SETTING THE MINIMUM LEVEL :

1. Turn on the lights and turn control clockwise to full brightness.
2. Press to turn off.
3. While off, turn control knob fully anti clockwise.
4. Press again to turn on. The lights will flash to indicate that you are now in programming mode.
5. Select the minimum light level required.
6. Release the control and wait for five seconds. The lights will flash again to indicate the minimum level has been stored.

You now have the option to set the start & maximum levels (see below) or simply wait until the lamps flash twice more indicating that normal dimmer operation is resumed.

SETTING THE START LEVEL :

After following points 1-6 above, you have 5 seconds to begin before the lights flash, indicating the next stage in the cycle. Select the level needed for your lamps to turn on consistently, then release the control and wait for another 5 seconds. The lights will flash once more to indicate both levels have been stored.

START LEVEL - BOOST FEATURE :

Some LED's require so much energy to start up that we've added another feature called the boost. If you find that the lamps do need this, simply set the start level to maximum and the boost is activated, giving the lamps an extra kick start to get going, after which they will smoothly adjust and operate as normal.

You now have the option to set the maximum level or again, you can simply wait until the lamps flash once more indicating that normal dimmer operation is resumed.

SETTING THE MAXIMUM LEVEL

Finally you have the option to set the maximum level. There are five seconds after the previous flash to begin. Select the maximum level then wait for five seconds. The lights will flash for the final time, indicating that your selection has been saved.

The added advantage of setting the maximum level is that the ZBAR1-10V will automatically adjust the controller to spread the minimum-maximum levels evenly throughout the rotation. This means no "Dead Travel" resulting in consistent user experience, regardless of how bright or dim the light levels have been set.

ZBARLED REMOTE DIMMER SPECIFICATIONS

PART NO.	ZBAR1-10V
DESCRIPTION	IN-LINE REMOTE DIMMING PACK
LAMP TYPE	ANY 1-10V LOAD
MAX FITTINGS	30 BALLASTS/LED DRIVERS
MAX CURRENT	10A
SIZE (mm)	140 X 40 X 37mm

ZANO ROTARY CONTROLLER OPTIONS

PART NO.	DESCRIPTION
ZMOBARCR	ROTARY CONTROLLER MODULE
ZGRIDBARCR	GRID ROTARY CONTROLLER
ZGRIDBARCRBLK	BLACK GRID ROTARY CONTROLLER
ZWHBARCR	PLATED ROTARY CONTROLLER

ZBAR1-10V MUST BE USED WITH A ROTARY CONTROLLER

INSTALLATION MUST BE CARRIED OUT BY A QUALIFIED ELECTRICIAN

- This product must be installed in accordance with the relevant wiring regulations.
- Switch off mains supply.
- Decide on a suitable location for the dimmer pack with adequate ventilation and ensure the dimmer is mounted away from insulation.
- Commence connections as per appropriate wiring diagrams and in accordance with the relevant wiring regulations.
- Incorrect wiring may result in product failure and / or irreparable damage to the product.

WIRING WITH ROTARY CONTROLLERS

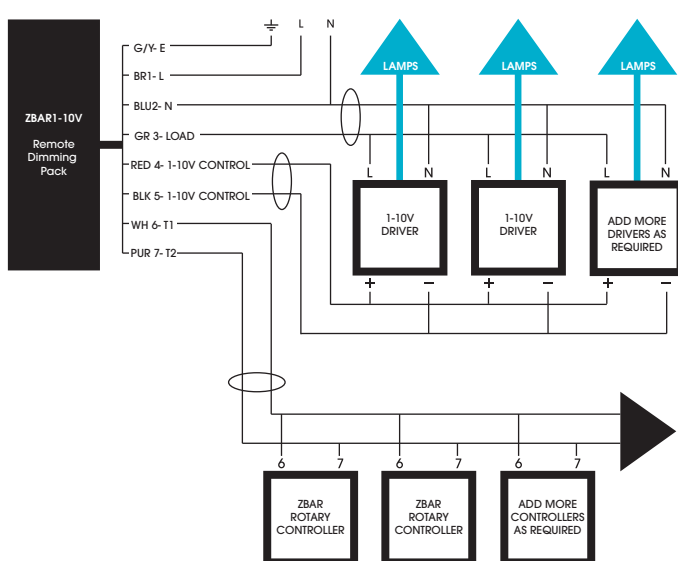

GENERAL WIRING DIAGRAM

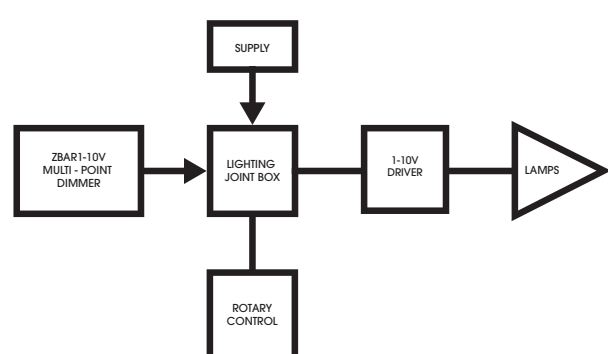

CONTACT OUR FRIENDLY TEAM

Unit 1 Chantry Court,
Wrythe Lane,
Carshalton,
Surrey,
SM5 2DG

Call : 0845 519 5858

Fax : 0845 519 5757

sales@zаноcontrols.co.uk

www.zаноcontrols.co.uk

ABOUT ZANO CONTROLS

We are award winning manufacturers of LED dimming solutions and pride ourselves on providing fast, friendly, expert advice. Call us now on 0845 519 5858 for the answer to LED dimming. For our full range of products, technical advice & instructional films or to find your nearest stockists please see our website.

GUARANTEE

For lamp test results and our full terms and conditions please see our website: www.zanocontrols.co.uk.