

DO NOT DEVIATE FROM THESE PLANS!

**If you want to modify these plans IN ANY
WAY, please CALL US FIRST toll-free:**

1-877-966-3852

**Unapproved changes can cause your
Murphy bed to NOT WORK CORRECTLY
and will VOID your warranty.**

PLEASE NOTE:

**This kit is engineered to work with
ANY mattress that meets
these WEIGHT and THICKNESS
specifications:**

<u>SIZE OF BED</u>	<u>THICKNESS (including any pillow top)</u>	<u>WEIGHT</u>
TWIN	Up to 12 inches	35 to 50 pounds
FULL	Up to 12 inches	50 to 65 pounds
QUEEN	Up to 12 inches	65 to 80 pounds

Create-A-Bed[®] LLC

NOTE: DO NOT deviate from these plans

These plans are for constructing a
STANDARD
TWIN HORIZONTAL BED
using **PLYWOOD** material

If you are missing any parts or have ANY questions pertaining to materials or construction please phone the manufacturer.

TOLL FREE 1-877-966-3852

TOOLS NEEDED:

Power Drill
Drill Bits: 1/8", 1/4", 5/16"
1" Forstner Bit, 5/8" Forstner Bit
Power Saw, Table Saw or Circular Saw
Jigsaw or Coping Saw
Phillips-Head and Flat-Head Screwdrivers or Driver Bits for Drill
Tape Measure
#4 Allen Wrench
Hammer
Clamps
Straight Edge or Framing Square
Household Iron for Veneer Tape and Utility Knife

© *Create-A-Bed[®] LLC 2003, 2008, 2018, 2021*

murphy bed mechanism

1800 Taylor Avenue Louisville, KY 40213

www.createabed.com

TOLL FREE: 1-877-966-3852

Create-A-Bed®

C.A.B., Inc.

TWIN HORIZONTAL (SIDEBED) murphy bed mechanism
PLYWOOD construction



Two (2) PISTONS

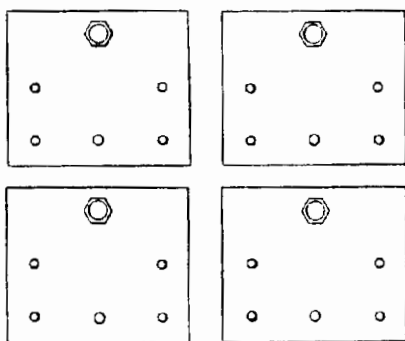

Four (4) BALL STUD PLATES with twelve (12) black #10 x 3/4" screws and eight (8) "T" nuts with machine screws



Two (2) BED STOPS with two (2) #8 x 5/8" round head SCREWS

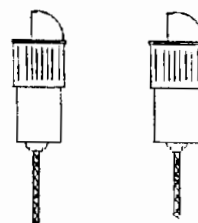

Two (2) LOCKING SPRING LATCHES with CABLES

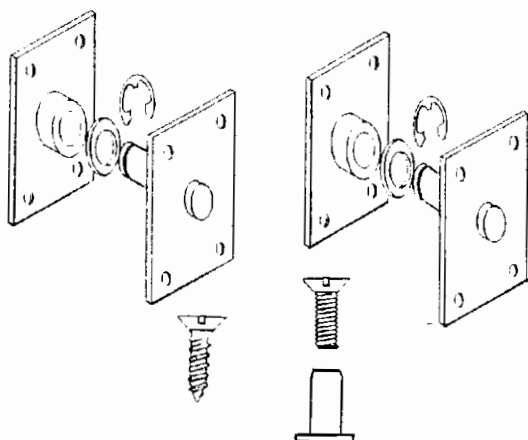

Two (2) pair of METAL PIVOTS with two (2) WASHERS
 two (2) "E" CLIPS
 four (4) "T" nuts with MACHINE SCREWS
 twelve (12) #12 x 3/4" zinc SCREWS

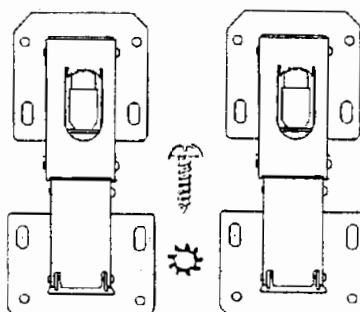

Two (2) double-acting, fully-concealed LEG HINGES with sixteen (16) #8 x 5/8" round head MOUNTING SCREWS with two (2) LOCK WASHERS

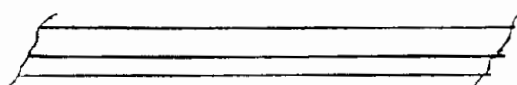

Two (2) ELASTIC MATTRESS RETAINING STRAPS

- One (1) yellow PLYWOOD CONSTRUCTION booklet
- One (1) white PARTICLE BOARD CONSTRUCTION booklet
- One (1) blue ASSEMBLY AND INSTALLATION booklet
- One (1) HORIZONTAL bed Construction, Assembly and Installation VIDEO.

Out-to-out dimensions of **HORIZONTAL STYLE**
 murphy bed cabinet constructed using the
Create-A-Bed[®] mechanism

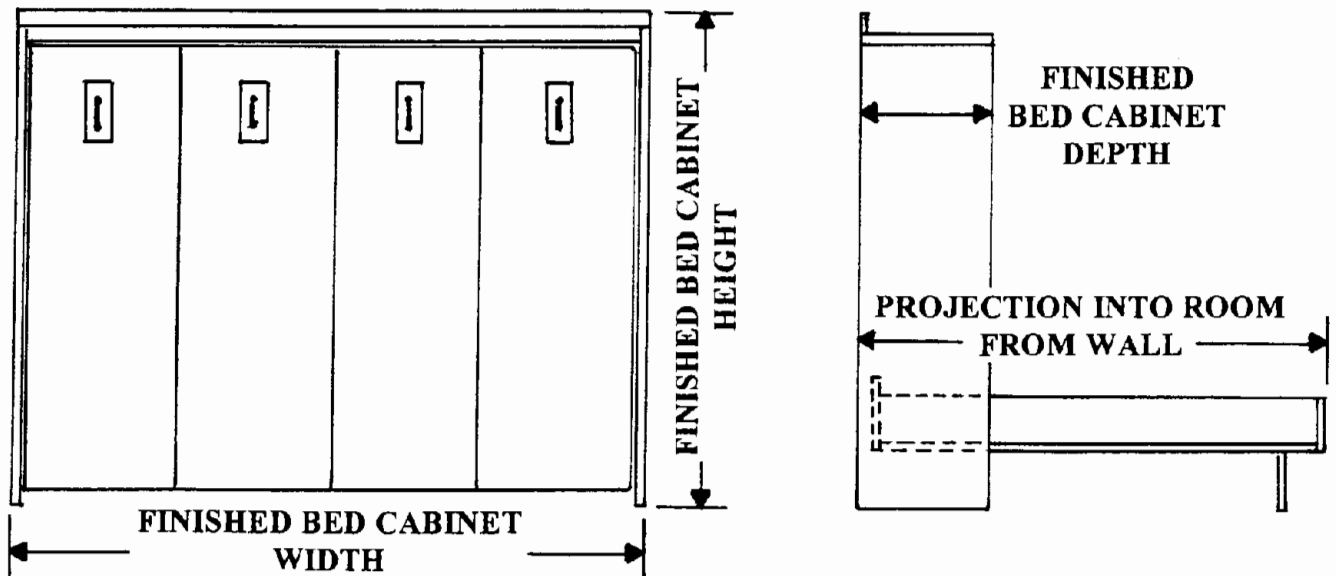

OUTSIDE-EDGE to OUTSIDE-EDGE FINISHED HORIZONTAL BED CABINET DIMENSIONS				
SIZE	HEIGHT	WIDTH	DEPTH	PROJECTION
Twin	47 3/8"	79"	15 7/8"	43"
Full	62 5/16"	79"	15 7/8"	58"
Queen	68 5/16"	84"	15 7/8"	64"

Some design options... or create your own!

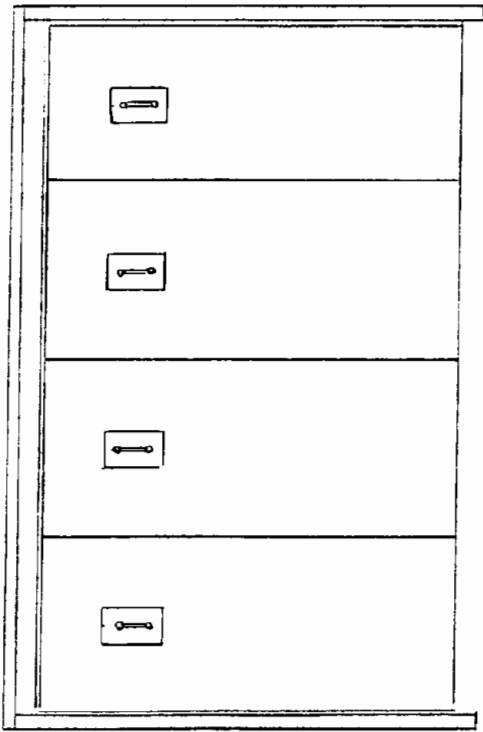

BASIC BED

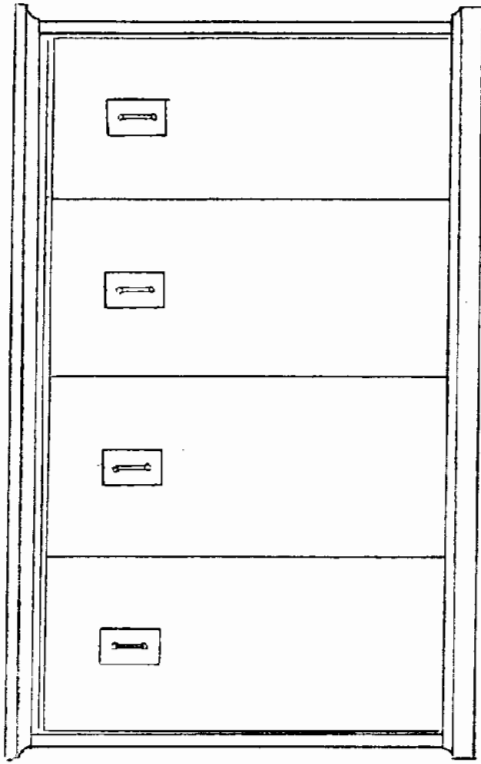

WITH CROWN
AND BASE MOLDING

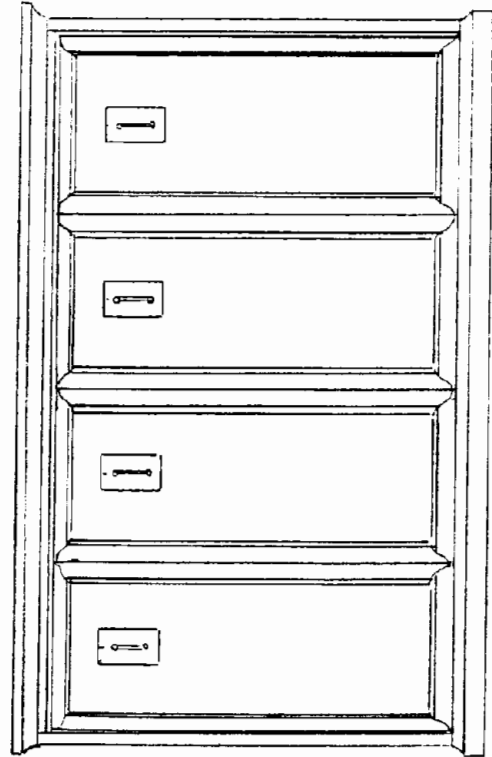

WITH CROWN, BASE
AND FULL-LENGTH
FACE PANEL MOLDING

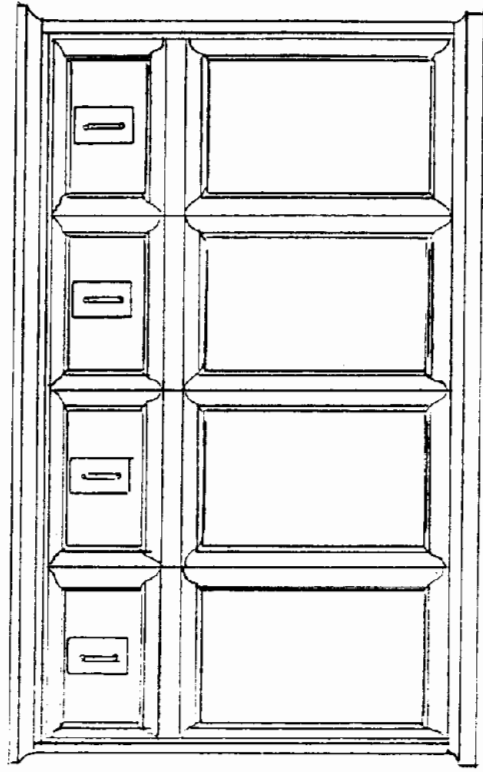

WITH CROWN, BASE
AND SPLIT
FACE PANEL MOLDING

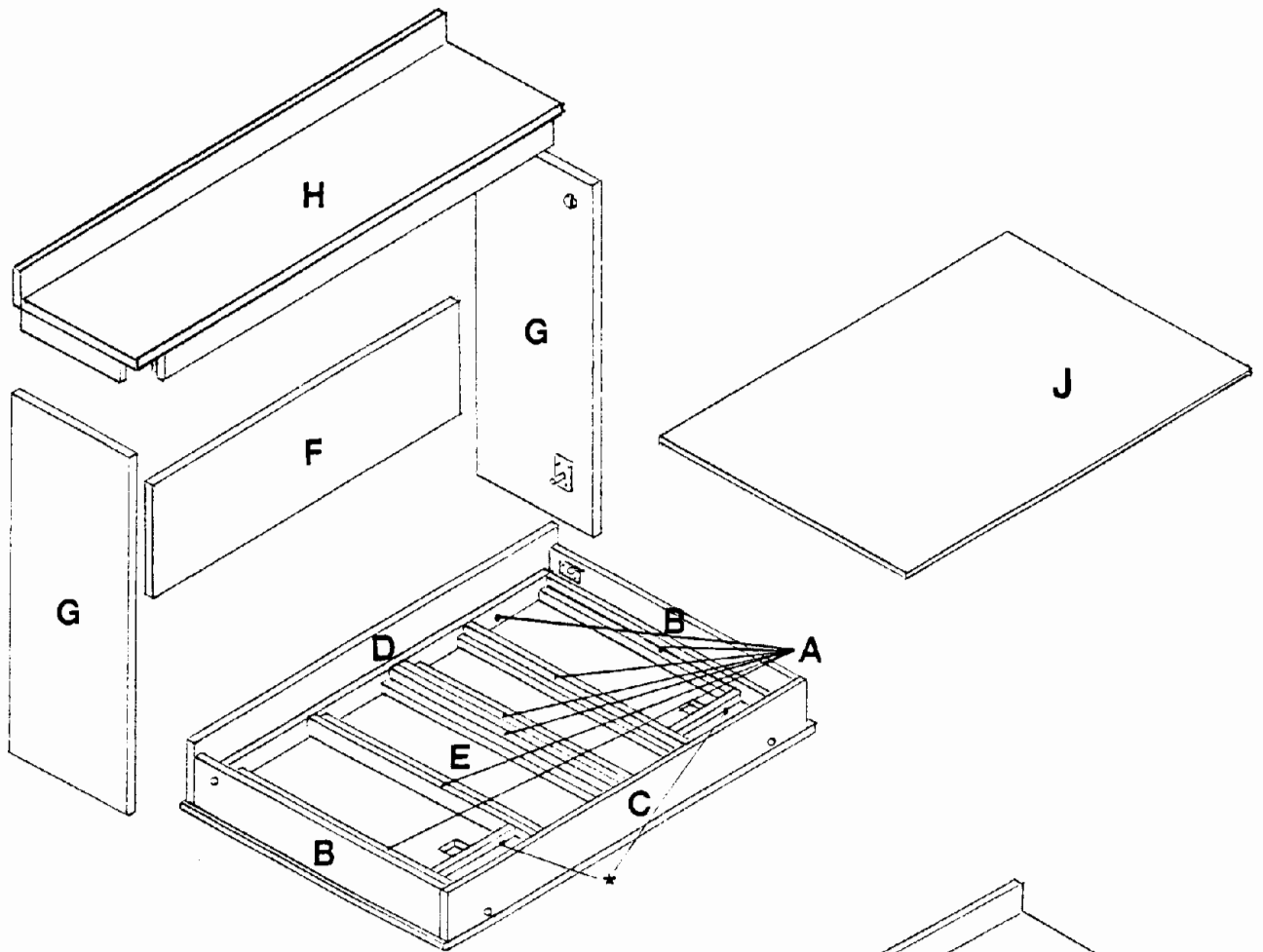

COMPONENTS OF FINISHED MURPHY BED:

- A. INNER WOOD BED FRAME & *LEG HINGE STRUTS
- B. SIDE RAILS
- C. FOOT RAIL
- D. HEAD RAIL
- E. BED FACE PANELS
- F. BED HEADBOARD
- G. BED CABINET VERTICALS
- H. BED HEADER
- I. WOODEN LEGS
- J. 1/4" PLYWOOD MATTRESS SUPPORT

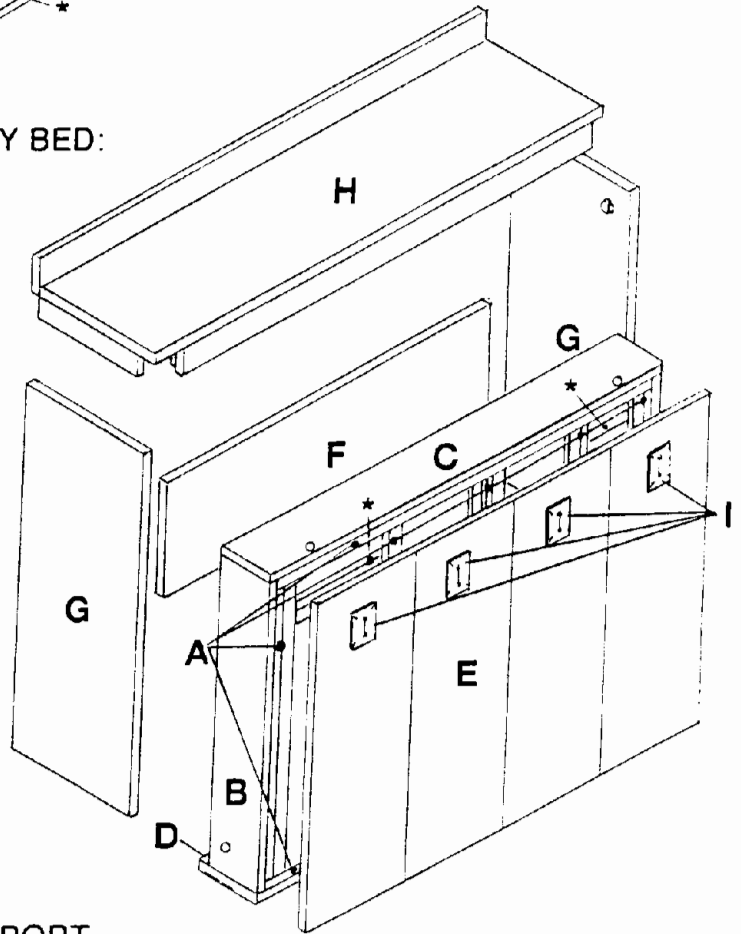

TWIN SIDEBED (HORIZONTAL) PLYWOOD CUTTING GUIDE

Requires 3 sheets of 3/4" x 4' x 8' and 1 sheet of 1/4" x 4' x 8'

NOTE: Refer to page 6 for the cutting dimensions.

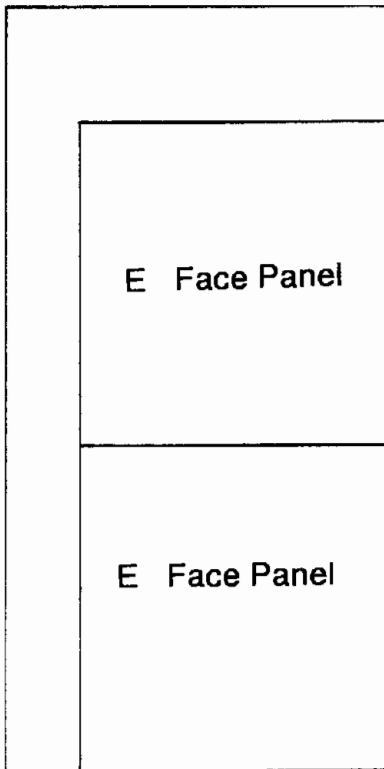

Requires 1 sheet 3/4"

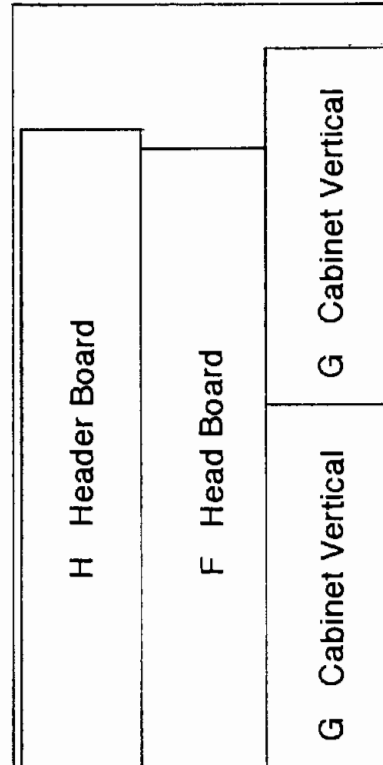

Requires 1 sheet 3/4"

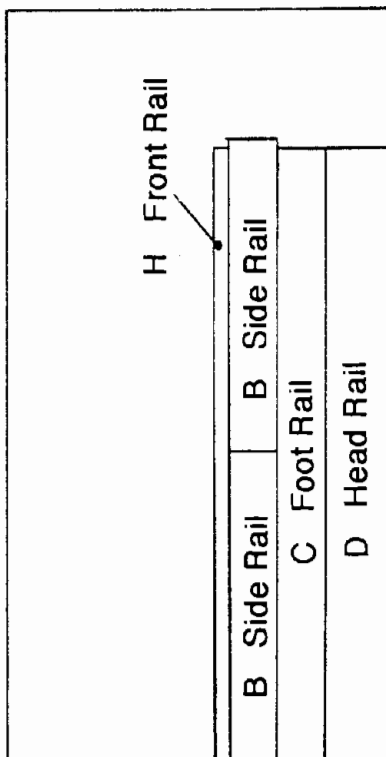

Requires 1 sheet 3/4"

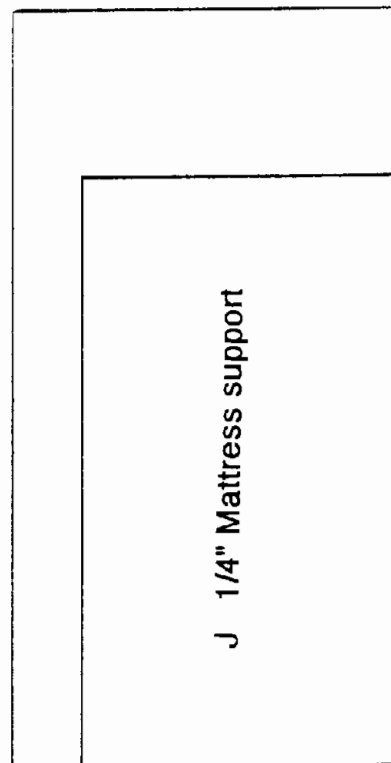

Requires 1 sheet 1/4"

**TWIN SIZE HORIZONTAL (side) BED CONSTRUCTED WITH 3/4" PLYWOOD
BILL OF MATERIALS / CUT SHEET**

___ check off as completed

___A. INNER WOOD BED FRAME:	*To be constructed of solid wood: poplar, clear pine, maple, etc.	
FRAME STRUTS:	*Solid wood: 3/4" X 1-1/2" X 37-1/2"	12 pieces
FRAME SIDES:	*Solid wood: 3/4" X 1-1/2" X 75"	2 pieces
LEG HINGE STRUTS:	*Solid wood: 3/4" X 1-1/2" X 13-1/2"	4 pieces

IMPORTANT: PLYWOOD MATERIAL MUST BE USED ON THESE PIECES:

___B. SIDE RAILS:	3/4" X 5-7/8" X 39"	2 pieces
___C. FOOT RAIL:	3/4" X 5-7/8" X 76-1/2"	1 piece
___D. HEAD RAIL:	3/4" X 7-7/8" X 76-1/2"	1 piece
___E. BED FACE PANEL:	3/4" X 38-1/2" X 40-3/4"	2 pieces
___F. BED HEADBOARD:	3/4" X 15-7/8" X 77-3/8"	1 piece
___G. BED CABINET VERTICALS:	3/4" X 15-7/8" X 45-3/8"	2 pieces
___H. BED HEADER:		
HEADERBOARD:	3/4" X 15-1/8" X 78-7/8"	1 piece
FRONT RAIL:	3/4" X 2" X 77-3/8"	1 piece
FRONT RAIL SUPPORT:	*Solid wood: 3/4" X 1-1/2" X 77-3/8"	2 pieces
REAR RAIL:	*Solid wood: 3/4" X 2" X 78-7/8"	1 piece
MOUNTING CLEATS:	* Solid wood: 3/4" X 1" X 12"	2 pieces
___I. BED LEGS:	*Solid wood: 3/4" X 3" X 7"	4 pieces
___J. 1/4" PLYWOOD mattress support:	1/4" X 39" X 75"	1 piece
___K. VENEER or MELAMINE TAPE:	13/16" X 75 feet	
___L. WOOD GLUE:	One 8 ounce bottle	
___M. CONSTRUCTION ADHESIVE:	One 10 ounce tube	
___N. FINISH NAILS:	One box of 1 1/4" One box of 1 1/2"	
___O. SCREWS:	#8 1 1/4" coarse thread Box of 100 #8 1 1/2" coarse thread 30 #8 2" coarse thread 40	

___P. INNERSPRING MATTRESS weighing 30 pounds or more

NOTE: Make sure your mattress dimensions DO NOT exceed 39" x 75."

Mattress thickness not to exceed 12"

A. INNER WOOD BED FRAME

See Bill of Materials / Cut Sheet (PART A) for twin, full or queen size frame struts and frame sides dimensions.

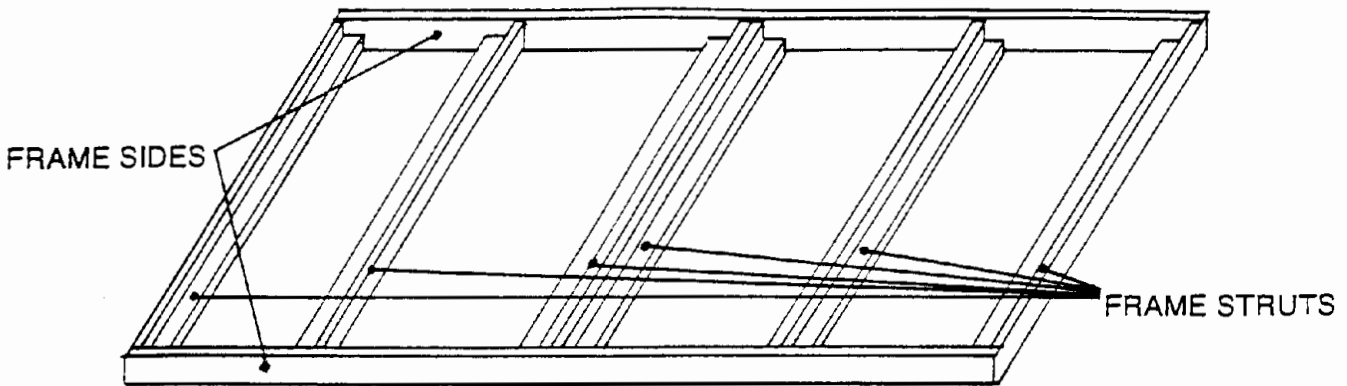

STEP 1: Construction of Six (6) frame struts and Two (2) leg hinge struts.

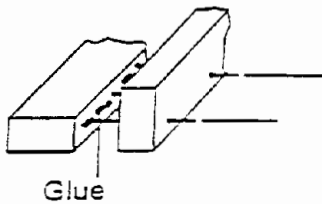

Run a bead of wood glue along inside edge. Making sure ends are flush drill pilot holes approximately 8" apart and nail with 1 1/2" finish nails, or you can use #8 1 1/2" screws.

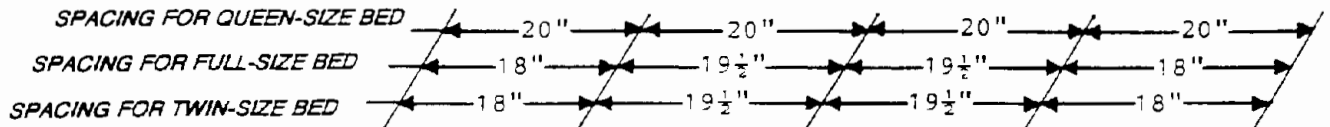
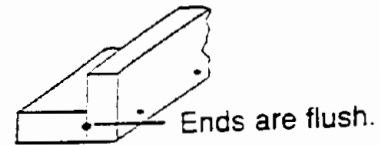

STEP 2: Position of frame struts between frame sides.

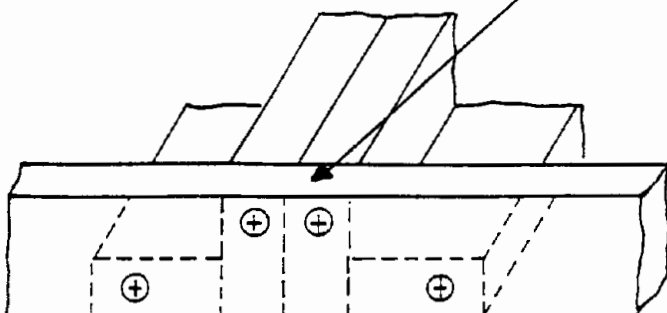
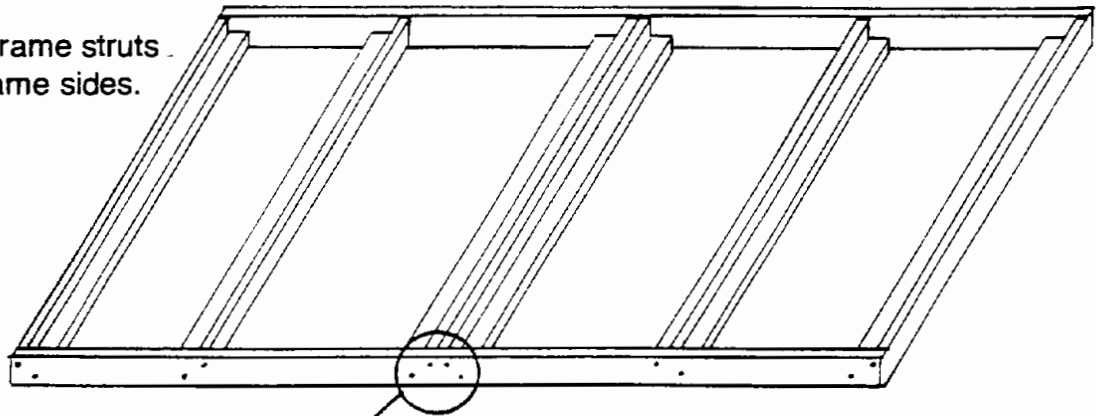

STEP 3: Mounting the frame struts between the frame sides.

Using a 1/8" drill bit and countersink, drill pilot holes through the frame sides into each end of the "L" shaped frame struts. Screw #8 x 2" wood screws flush.

PART B. Side Rails: (must be made of plywood) Why?... This is where the stress takes place, Plywood is stronger than solid wood.

PART C. Foot Rail

PART D. Head Rail

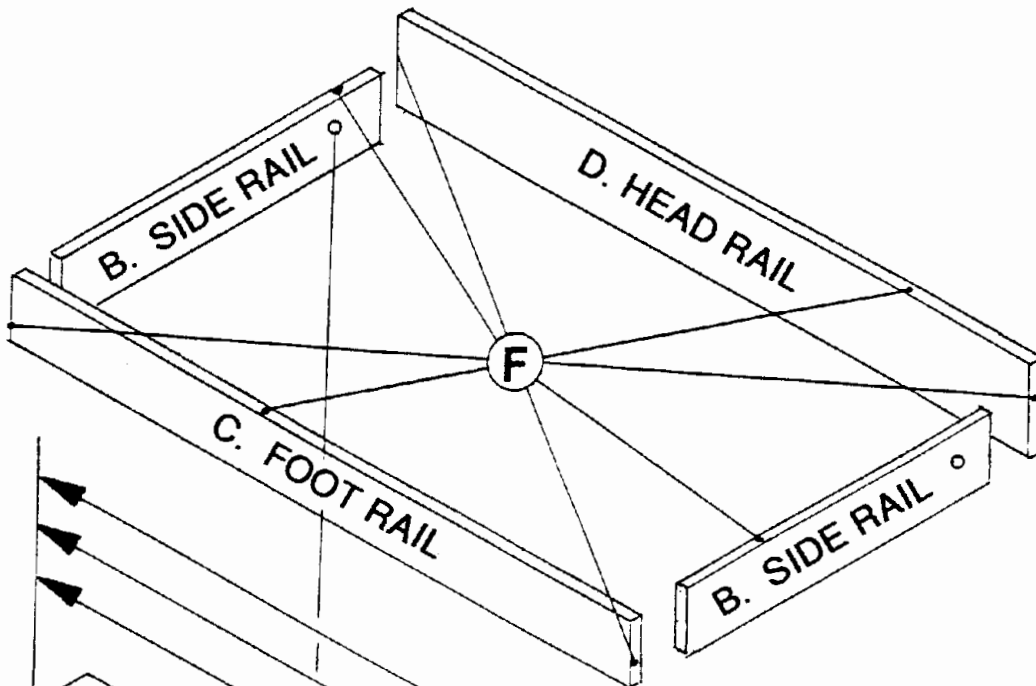

Note: For a finished look, apply wood veneer or melamine edge tape to all edges marked (F)

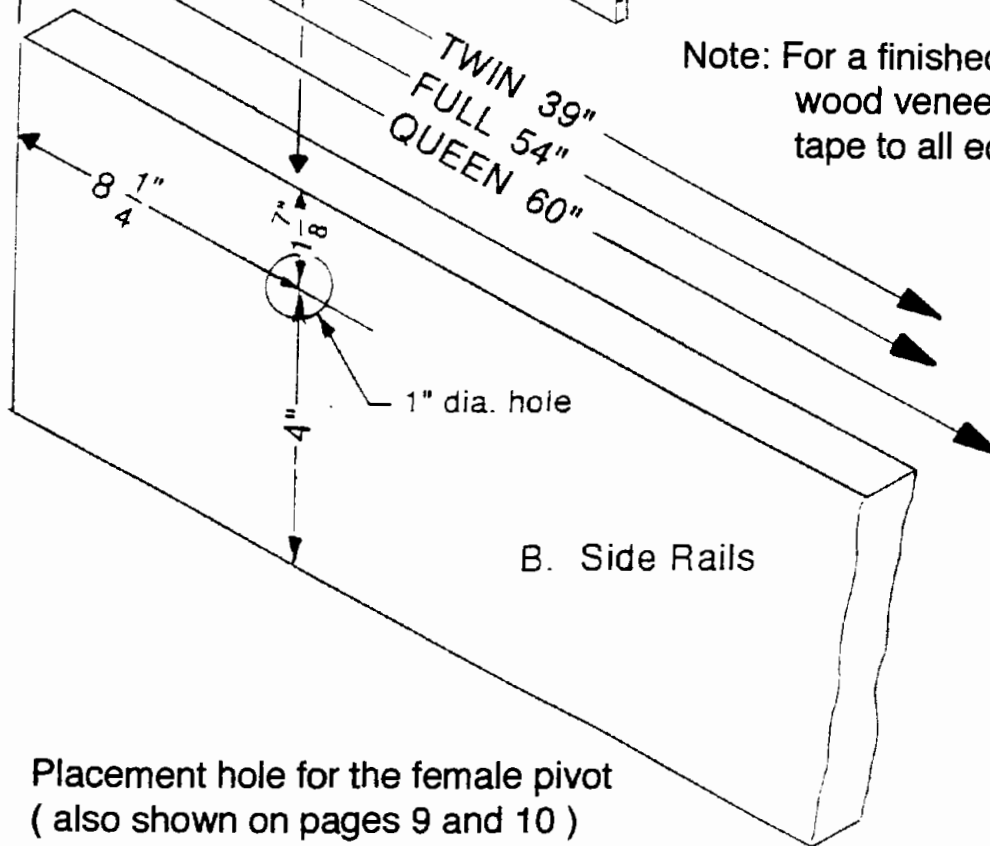

Placement hole for the female pivot
(also shown on pages 9 and 10)

This page pertains to the orientation and mounting positions of the lower ball stud plate and female pivot -
USE WITH PAGES 9, 10, & 11

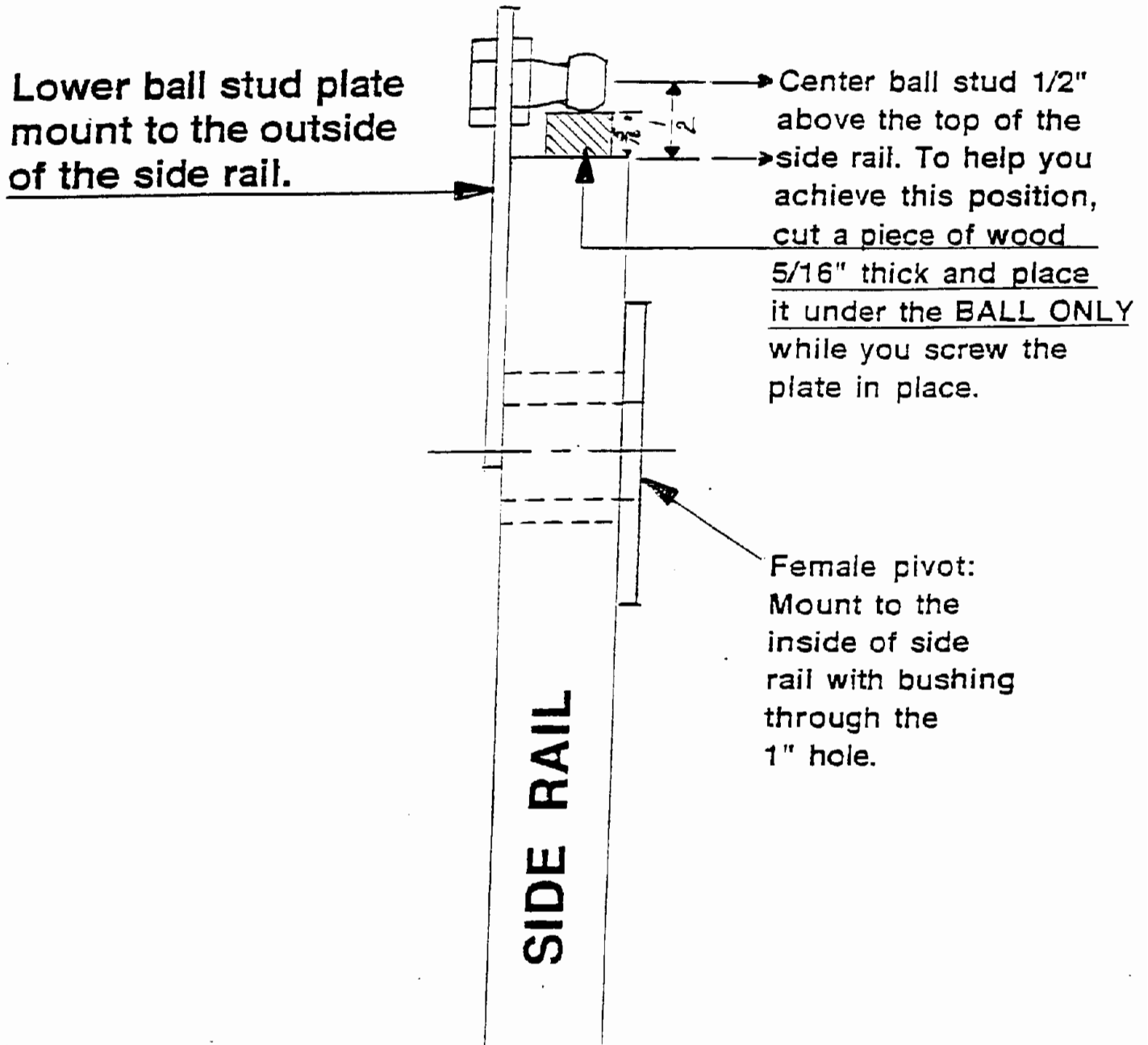

STEP 4: Mounting the lower ball stud plate to the outside of the side rail PARTS B

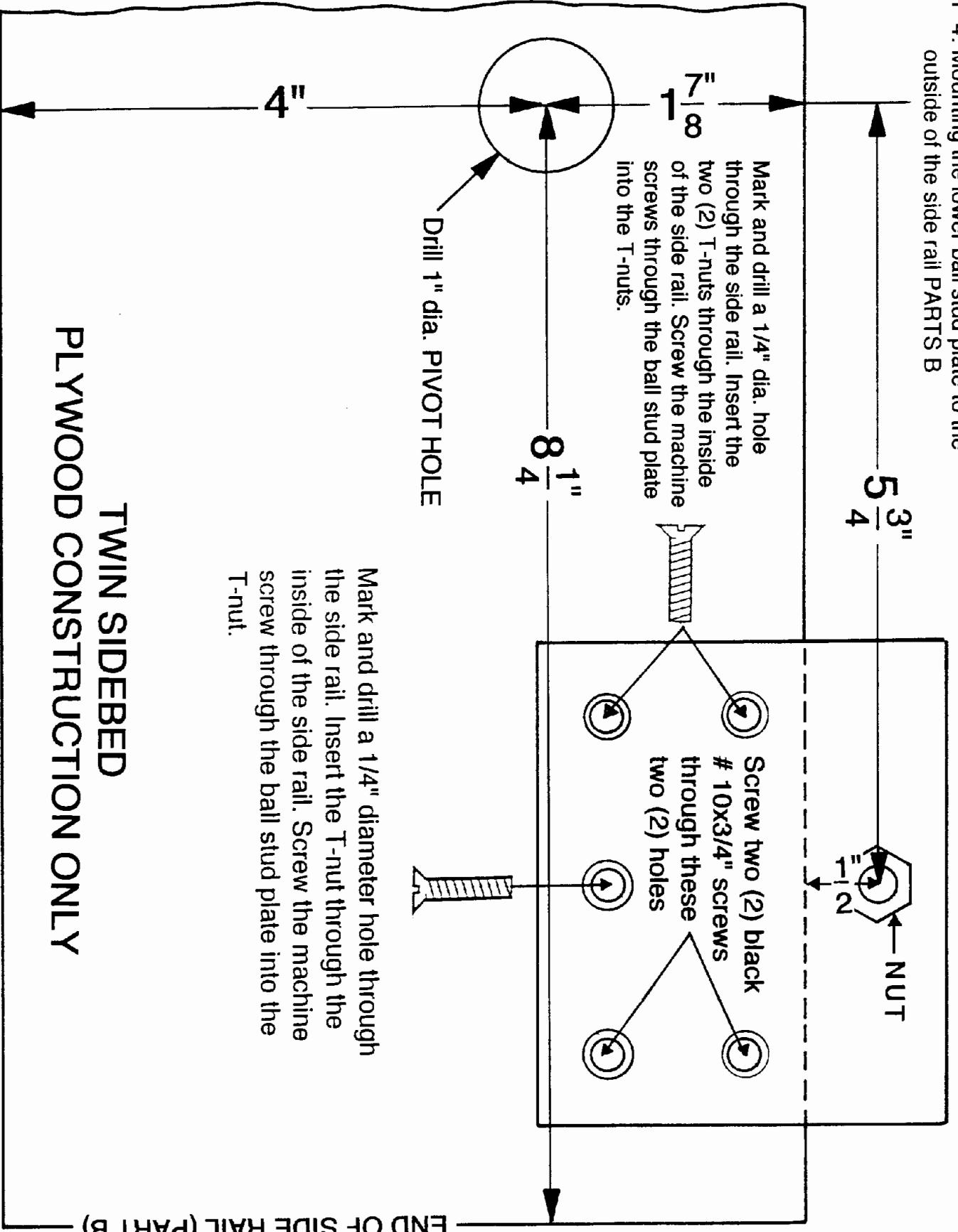

Mark and drill a 1/4" dia. hole through the side rail. Insert the two (2) T-nuts through the inside of the side rail. Screw the machine screws through the ball stud plate into the T-nuts.

Drill 1" dia. PIVOT HOLE

Mark and drill a 1/4" diameter hole through the side rail. Insert the T-nut through the inside of the side rail. Screw the machine screw through the ball stud plate into the T-nut.

TWIN SIDEBED
PLYWOOD CONSTRUCTION ONLY

END OF SIDE RAIL (PART B)

STEP 5: Mounting the lower ball stud plate to the outside of the side rail PARTS B

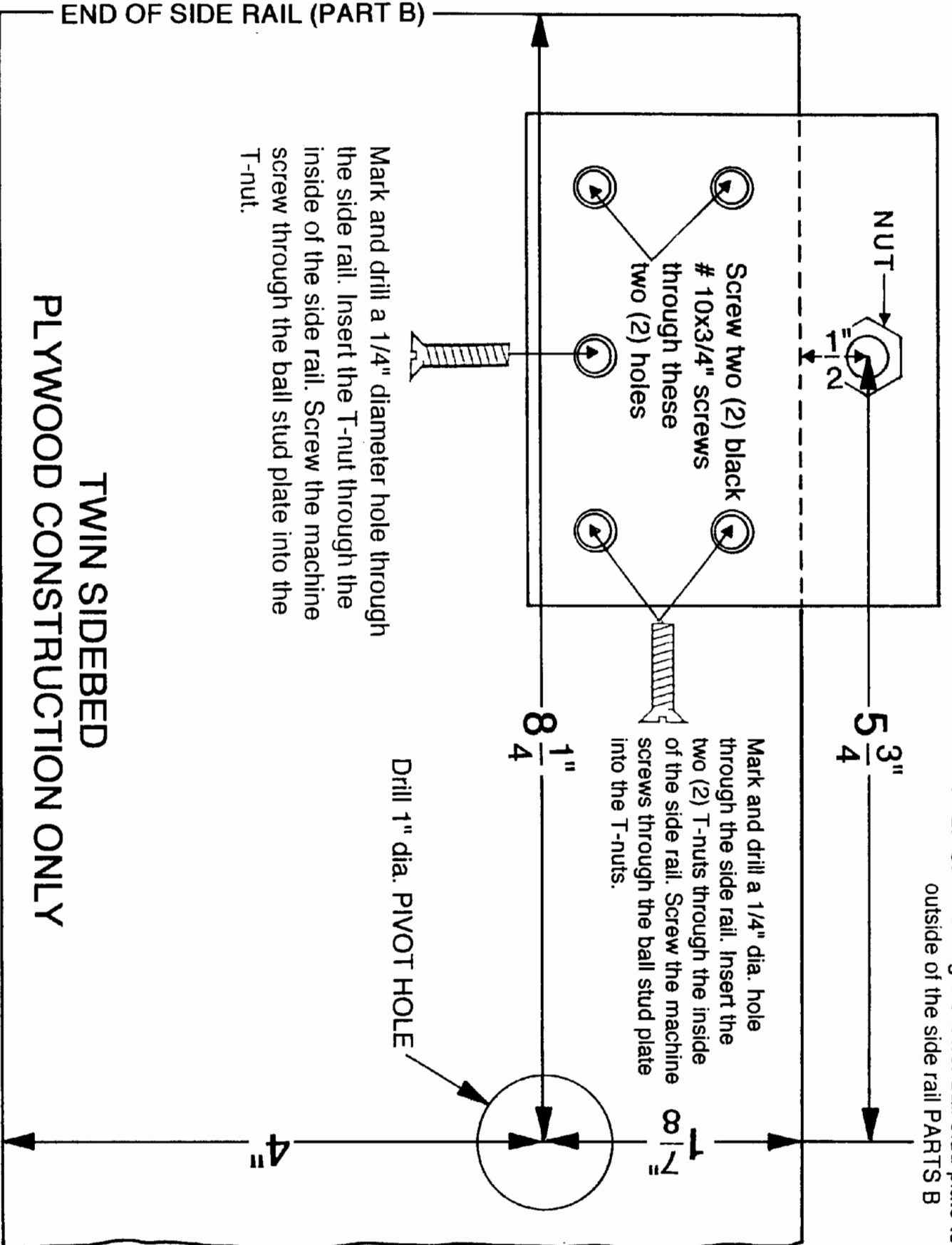

Mark and drill a 1/4" diameter hole through the side rail. Insert the T-nut through the inside of the side rail. Screw the machine screw through the ball stud plate into the T-nut.

**TWIN SIDEBED
PLYWOOD CONSTRUCTION ONLY**

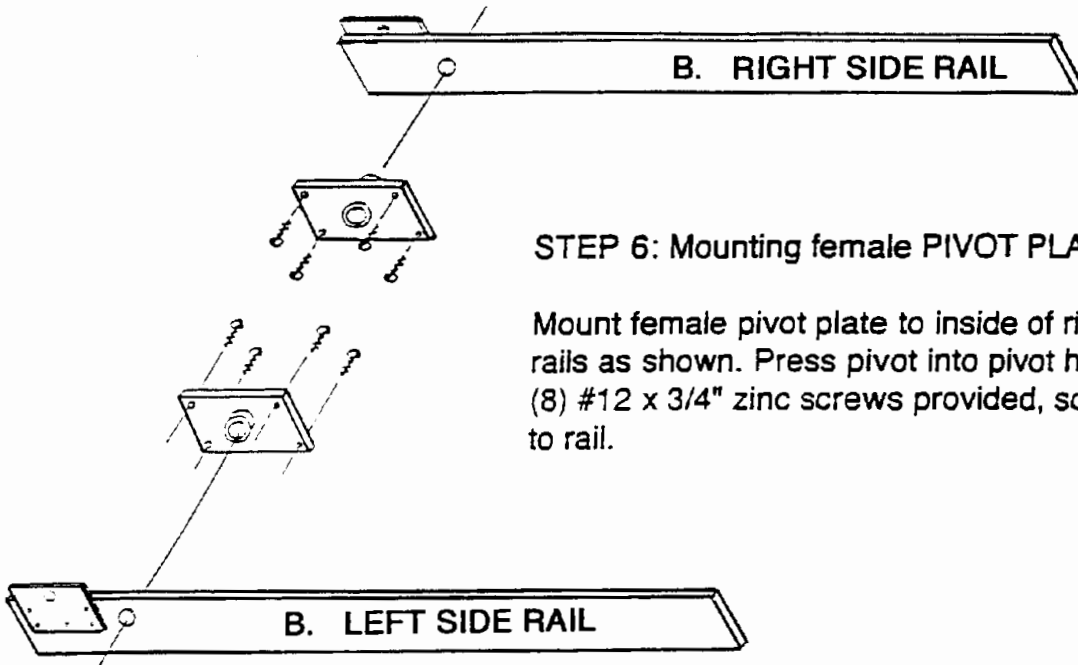

STEP 6: Mounting female PIVOT PLATES

Mount female pivot plate to inside of right and left side rails as shown. Press pivot into pivot hole. Using eight (8) #12 x 3/4" zinc screws provided, screw plate flush to rail.

STEP 7:
Mounting left and right side rails to inner wood bed frame.

Using an 1/8" drill bit, drill five holes 1-1/4 inches deep through the wood frame into the side rails. Drive #8 x 1-1/4 inch wood screws flush, snugging the inner wood bed frame to the side rail.

Pivot plates are mounted to the inside of the side rails B.

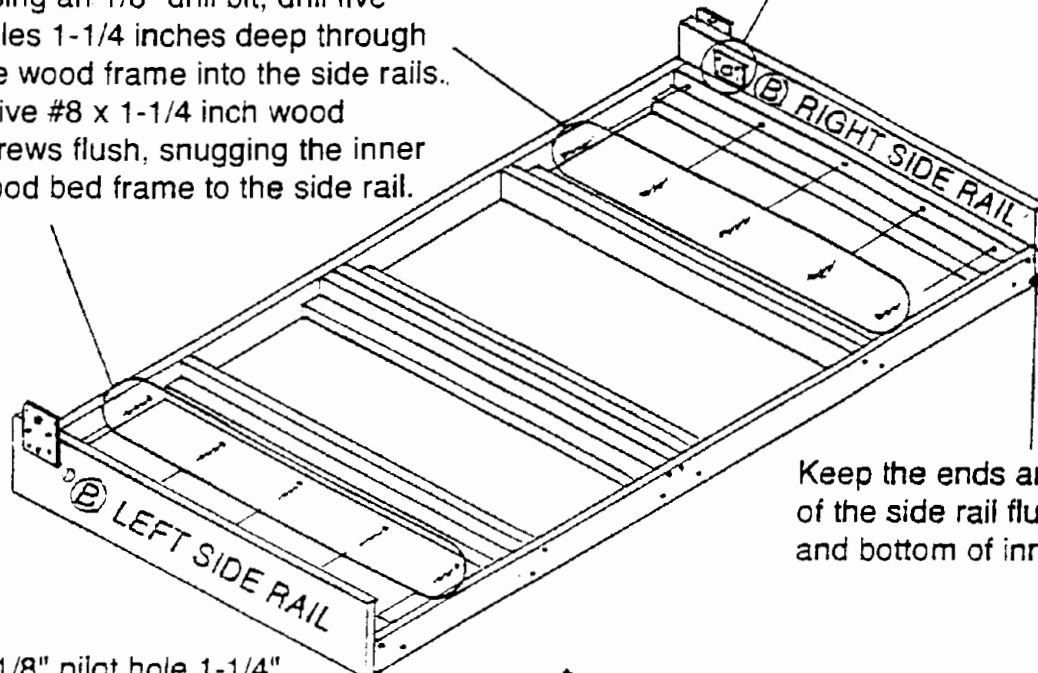

Keep the ends and bottoms of the side rail flush with ends and bottom of inner bed frame.

STEP 9:

Next, drill 1/8" pilot hole 1-1/4" deep through inner wood bed frame into foot rail. Drive 1-1/4" wood screws flush. Using the same instructions detailed in STEP 7, repeat STEPS 8 and 9 to attach the head rail PART D.

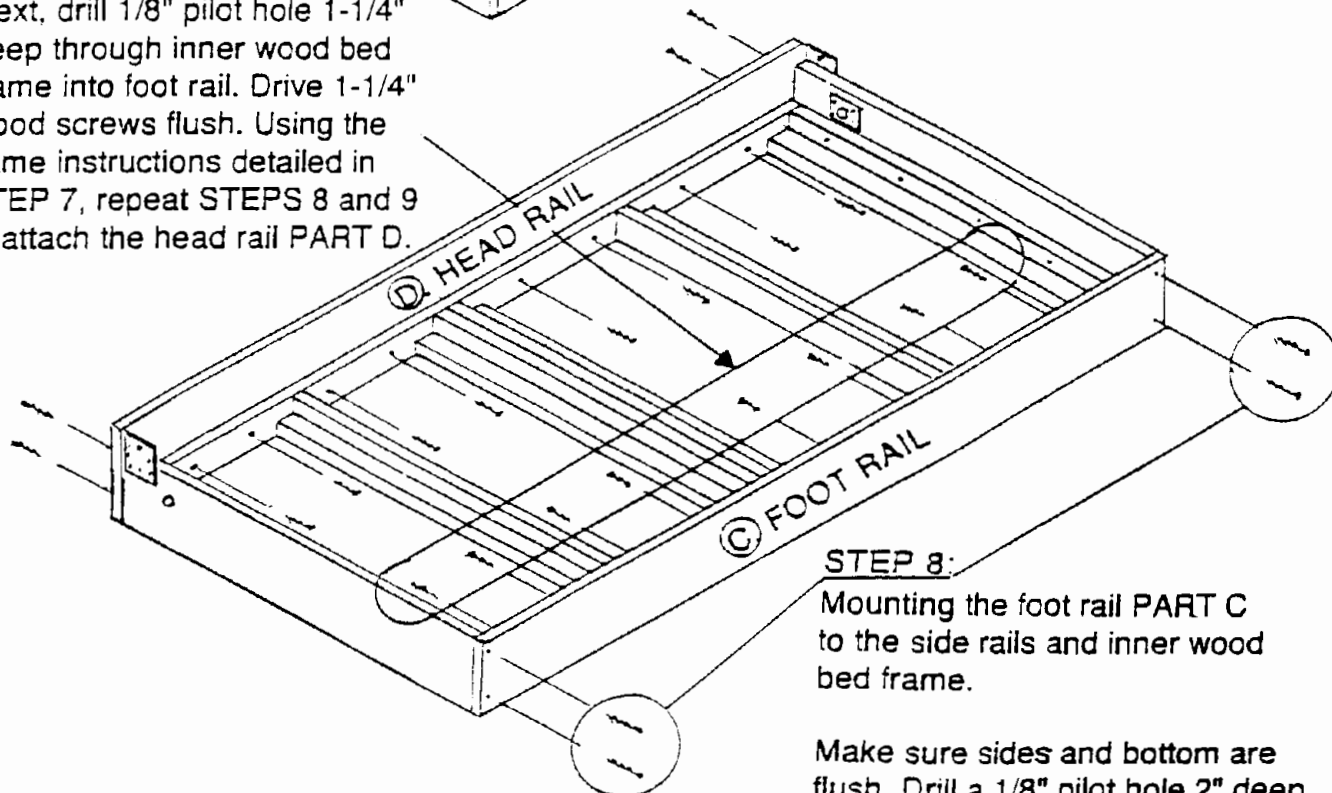

STEP 8:

Mounting the foot rail PART C to the side rails and inner wood bed frame.

Make sure sides and bottom are flush. Drill a 1/8" pilot hole 2" deep through foot rail into the side rails. Drive #8 x 2" wood screws flush.

E. BED FACEL PANEL(S)

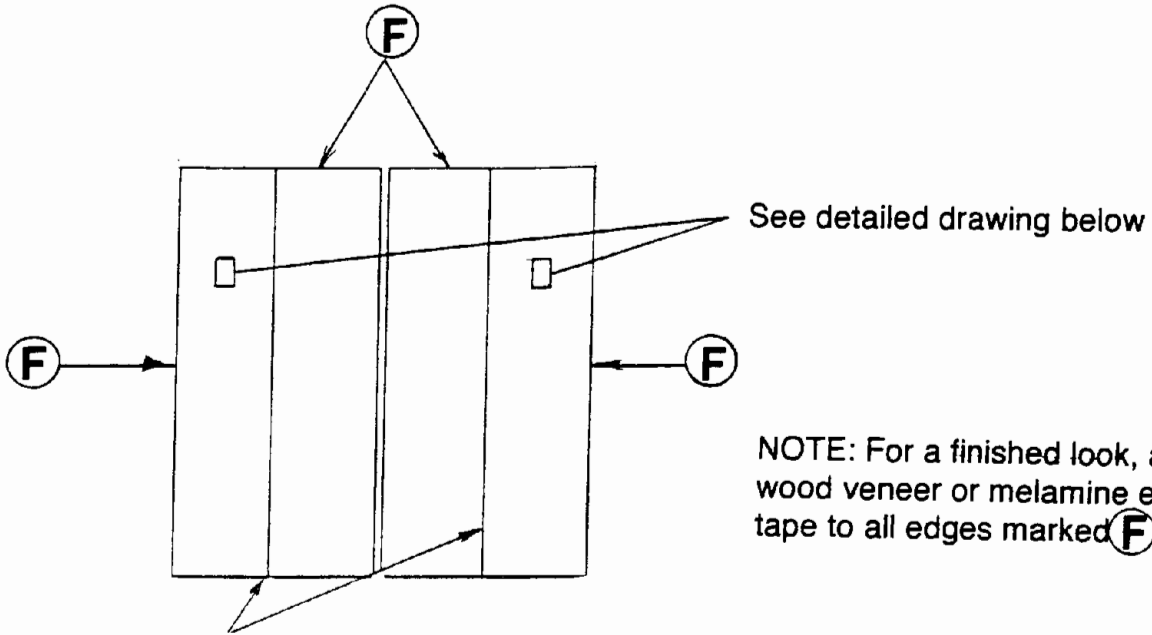

NOTE: For a finished look, apply wood veneer or melamine edge tape to all edges marked **F**

OPTION: For a bi-fold door look, score center of panels 1/8" deep the full length of the panels.

LEFT BED FACE PANEL

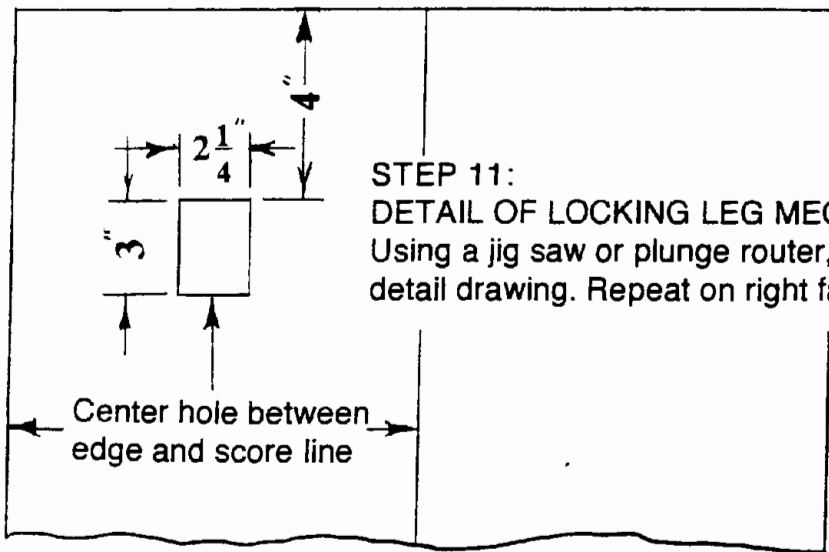

STEP 11:
 DETAIL OF LOCKING LEG MECHANISM CUT-OUT
 Using a jig saw or plunge router, cut out per dimensional detail drawing. Repeat on right face panel on right side.

STEP 12: Turn face panels over. On back side, mark a 1/4" line the full length of each panel along finished long edge.

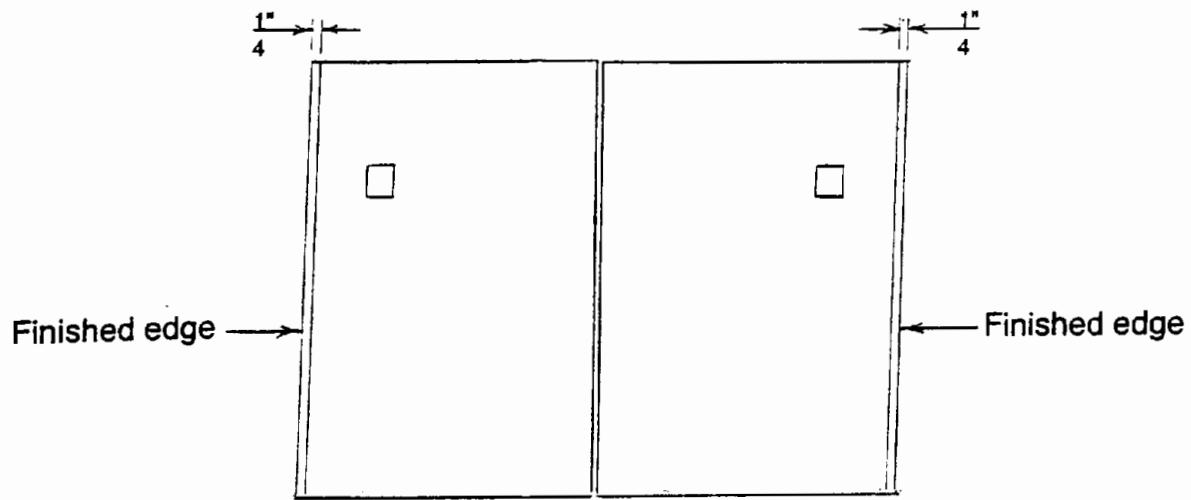

STEP 13:

Position bed face panels on a flat surface good side (with score lines) down, inside edges butted together and 1/4" pencil marks visible at outside finished edges.

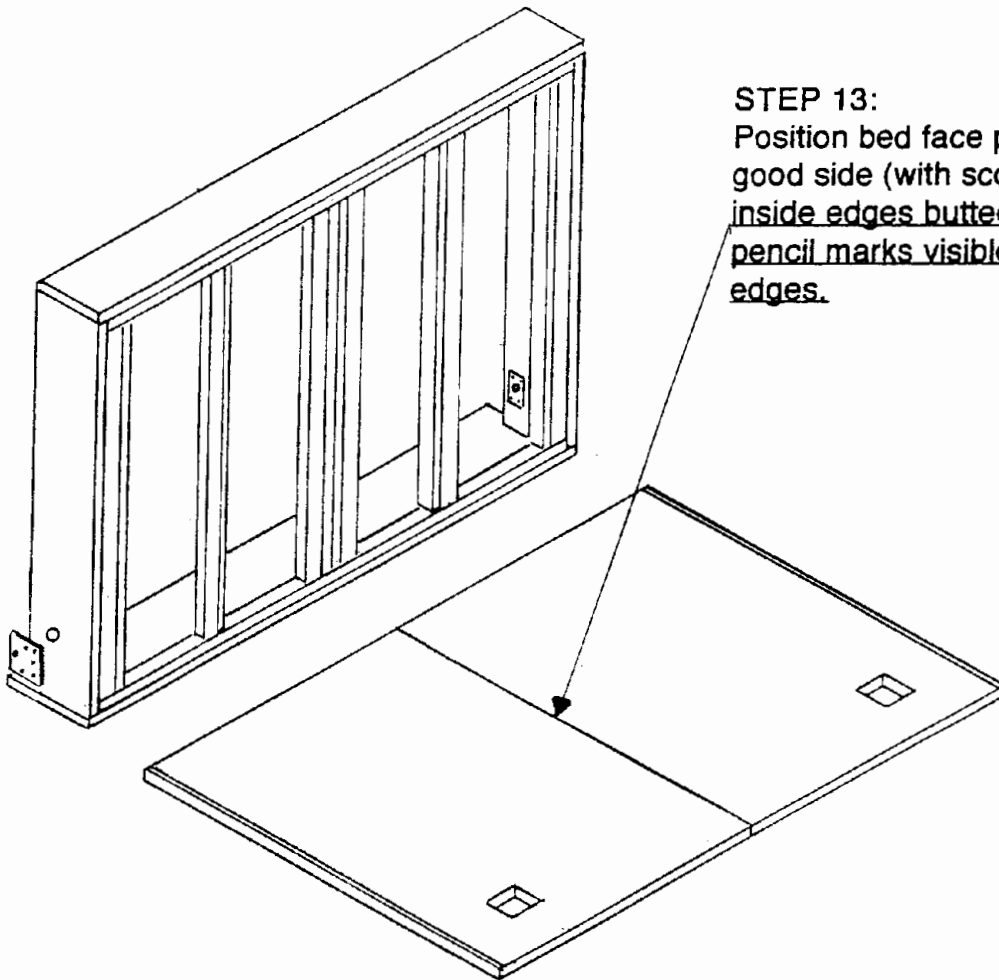

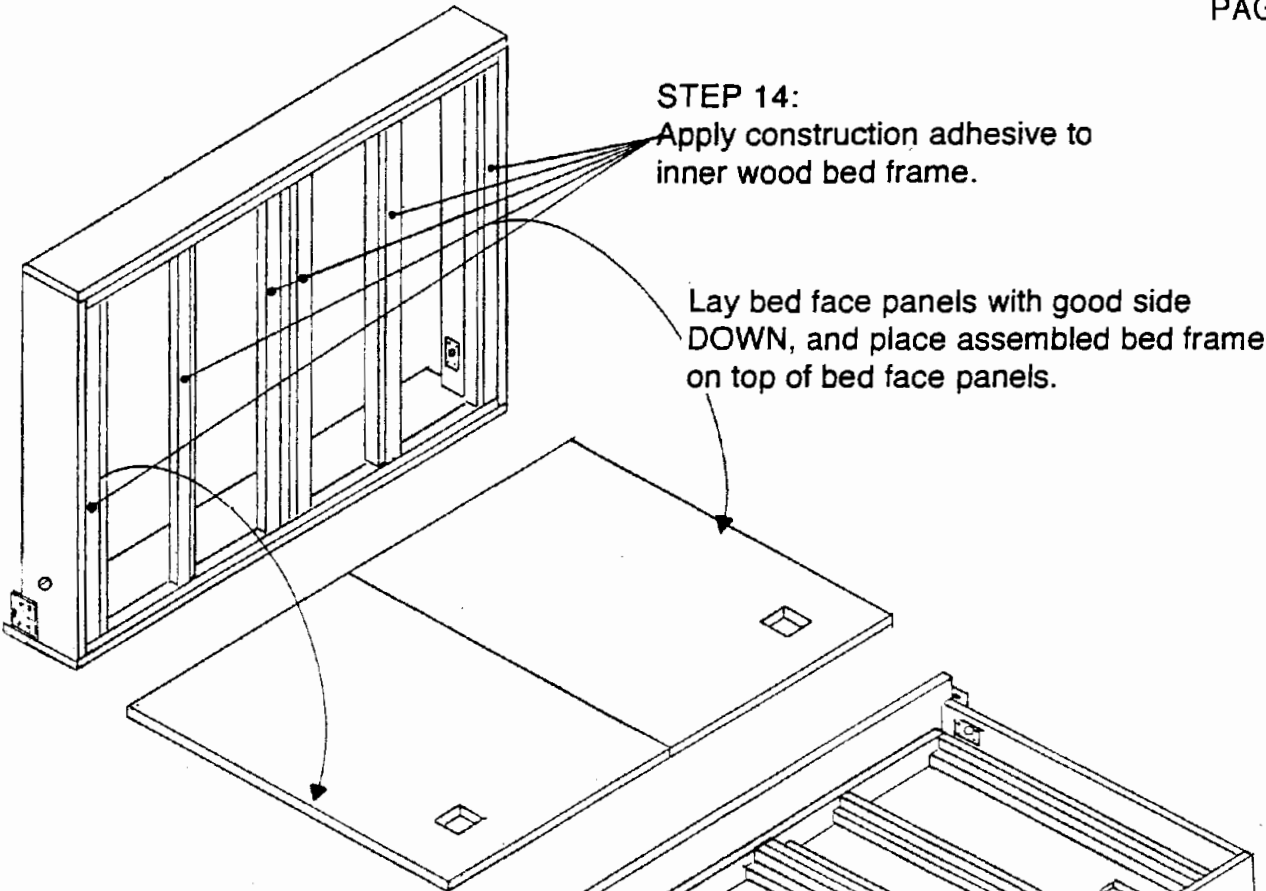

STEP 14:
Apply construction adhesive to inner wood bed frame.

Lay bed face panels with good side DOWN, and place assembled bed frame on top of bed face panels.

Face panel may extend approx. 1/4" at this end.

The face panel **MUST** extend 1/4" past edge of frame on long sides.

Face panels and foot rail **MUST** be flush at this end.

STEP 15:
Make sure face panel and foot rail are flush and that face panel extends 1/4" past edge of wood bed frame on long side.

Working **SIDE A** first:
Using #8 x 1-1/4" screws, screw section marked "X" first. Keeping end flush, screw section marked "Y".

Making sure there is a 1/4" face panel overhang, screw section marked "Z".

Repeat for **SIDE B**.

Screw remaining struts to face panel 6 inches apart

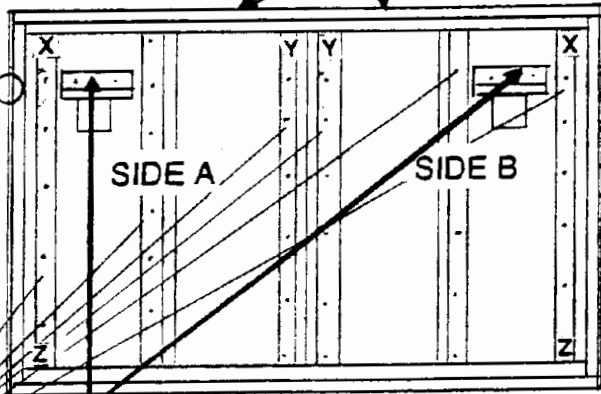

Apply construction adhesive and nail or screw the two (2) leg hinge struts to the inside of the face panel.
NOTE: Make sure these struts are flush with the top of the leg hole.

I. WOOD LEGS

NOTE: Make four (4) wood legs, 3/4" x 3" x 7".

ONLY two (2) legs will use the leg hinges. The other two (2) legs are fixed to the face panel and are used to lower the bed.

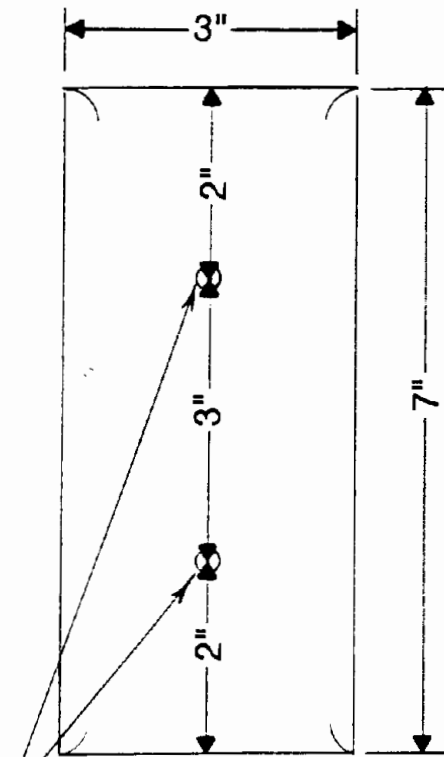

Drill two (2) 1/4" holes

NOTE: Centering of 1/4" holes may vary depending on style of pulls selected.

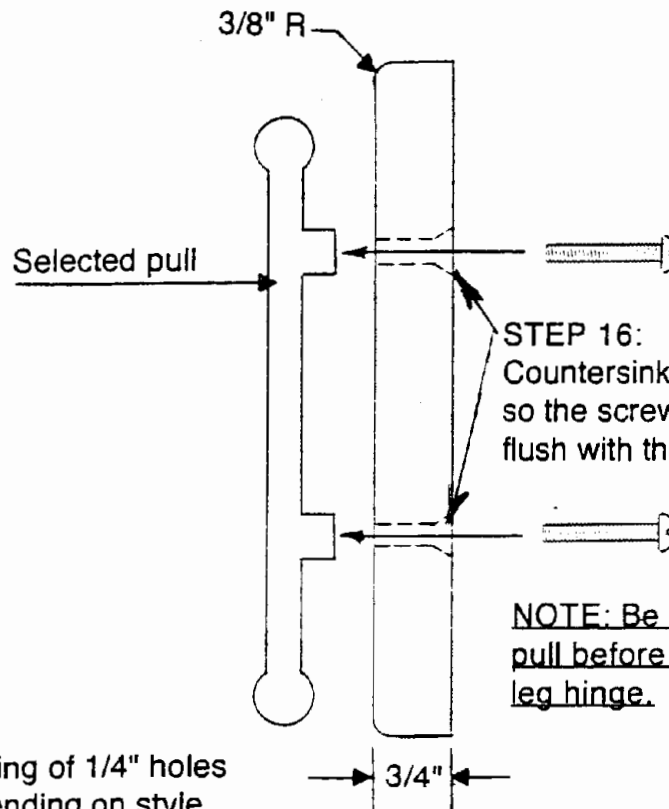

STEP 16: Countersink the screw holes so the screw heads will be flush with the wood leg.

NOTE: Be sure to mount pull before mounting leg hinge.

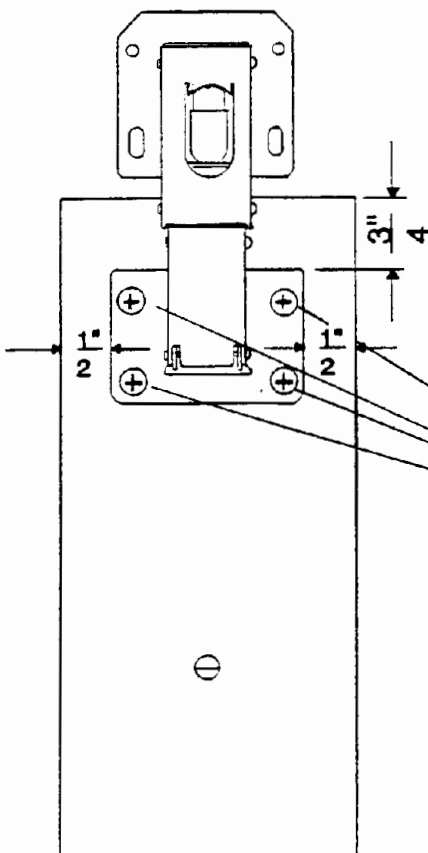

STEP 17: Position hinges on wood legs as shown. The measurements and orientation of the hinge on the leg are very important in the operation of the locking mechanism.

Drill pilot holes and screw four (4) #8 x 5/8" screws to secure hinge to leg.

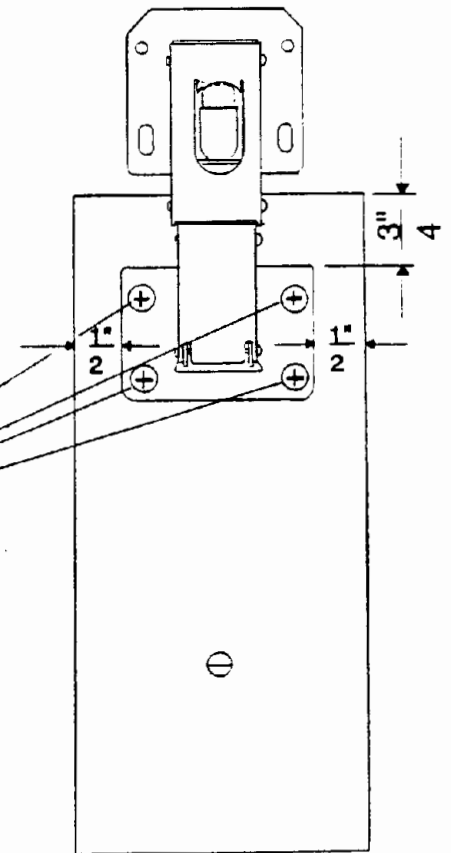

MOUNTING THE LEGS WITH ATTACHED HINGES TO BED FACE PANEL AND FRAME STRUT

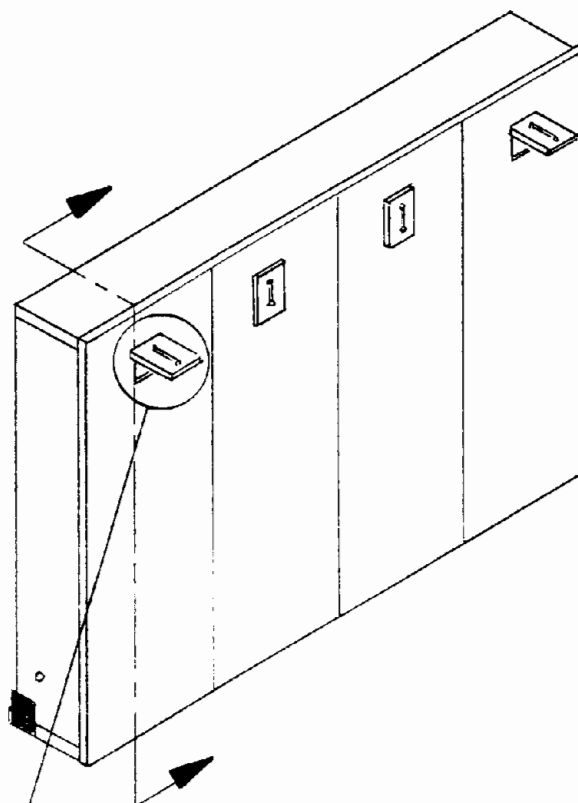

STEP 18:

Using the leg with hinge attached, push hinge through opening in face panel. Make sure wood leg is flush against face panel.

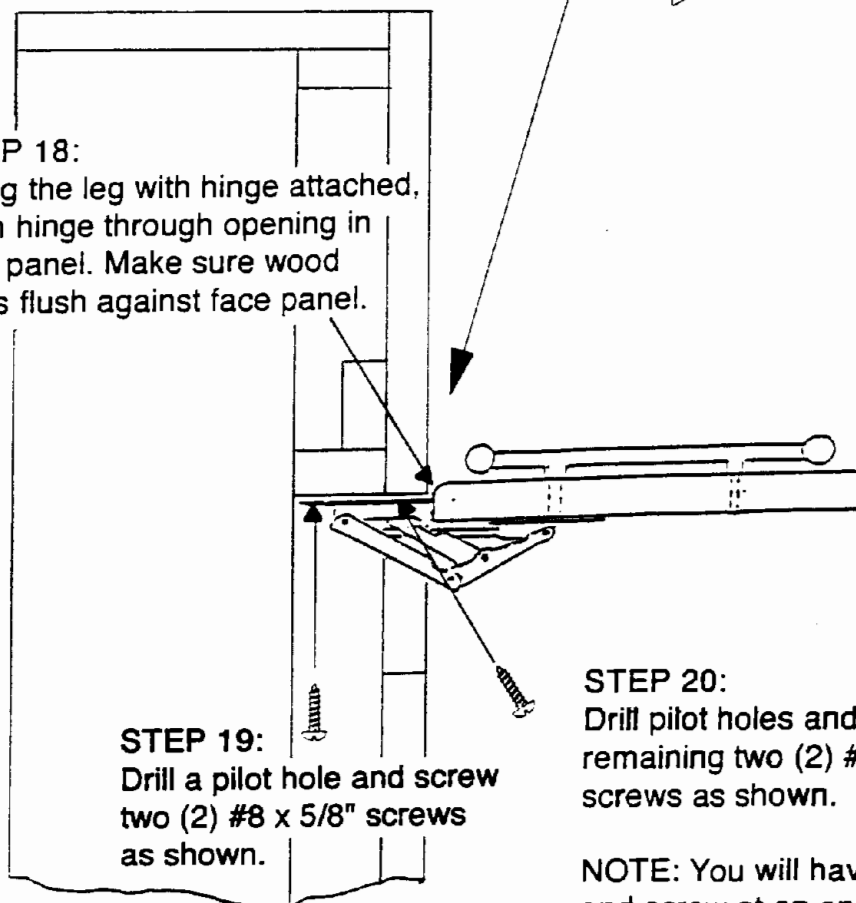

STEP 19:

Drill a pilot hole and screw two (2) #8 x 5/8" screws as shown.

STEP 20:

Drill pilot holes and screw remaining two (2) #8 x 5/8" screws as shown.

NOTE: You will have to drill and screw at an angle.

INSTALLING THE LOCKING LATCHES

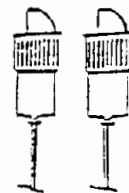
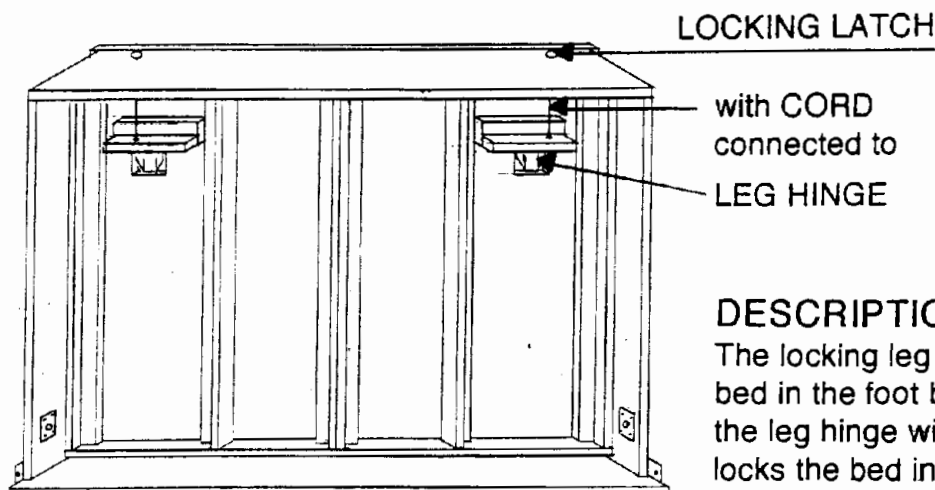

DESCRIPTION:

The locking leg latch is located at the top of the bed in the foot board. The latch is connected to the leg hinge with a length of cord. The latch locks the bed in its closed position - when the legs are opened, the cord retracts the latch and the bed can then be lowered for use.

NOTE: BE SURE TO PERFORM STEPS 21 THRU 30 IN ORDER...

STEP 25:
Drill a 1" diameter hole completely thru foot rail and frame strut.

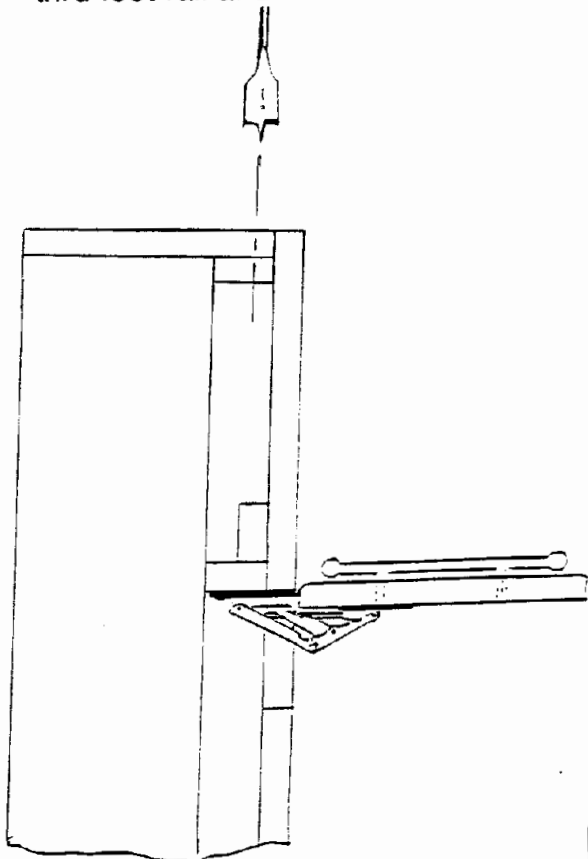

STEP 24:
From inside edge of face panel, measure 9/16" on foot rail and mark.

STEP 23:
From edge of foot rail, measure over same distance as in step 22, add 3/4" (thickness of side rail) and mark.

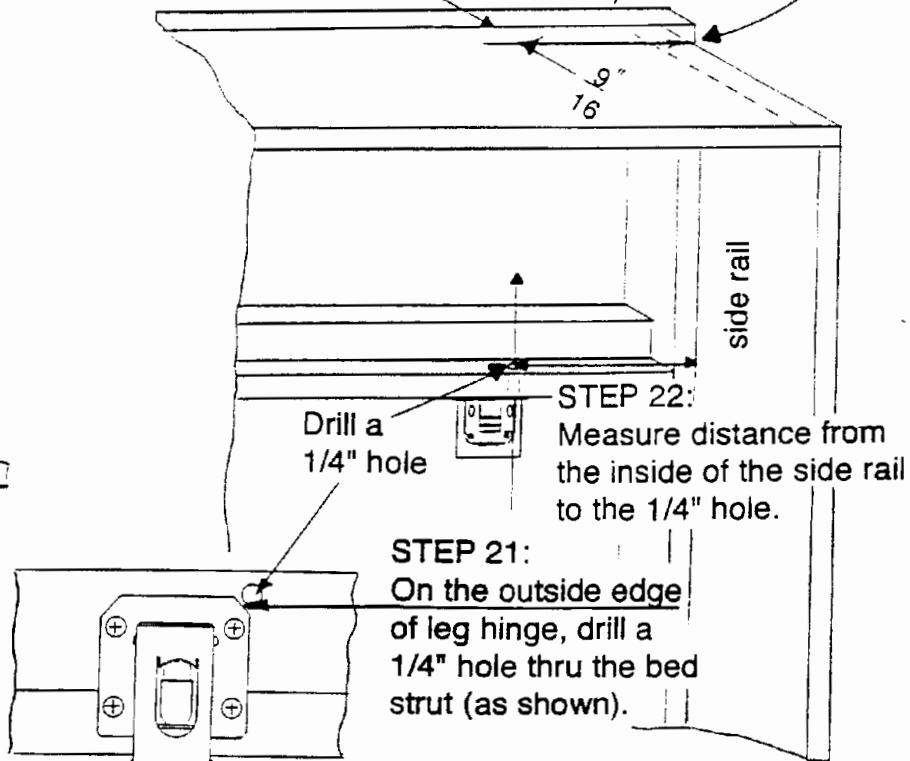

Underside View

INSTALLING THE LOCKING LATCHES (CONTINUED)

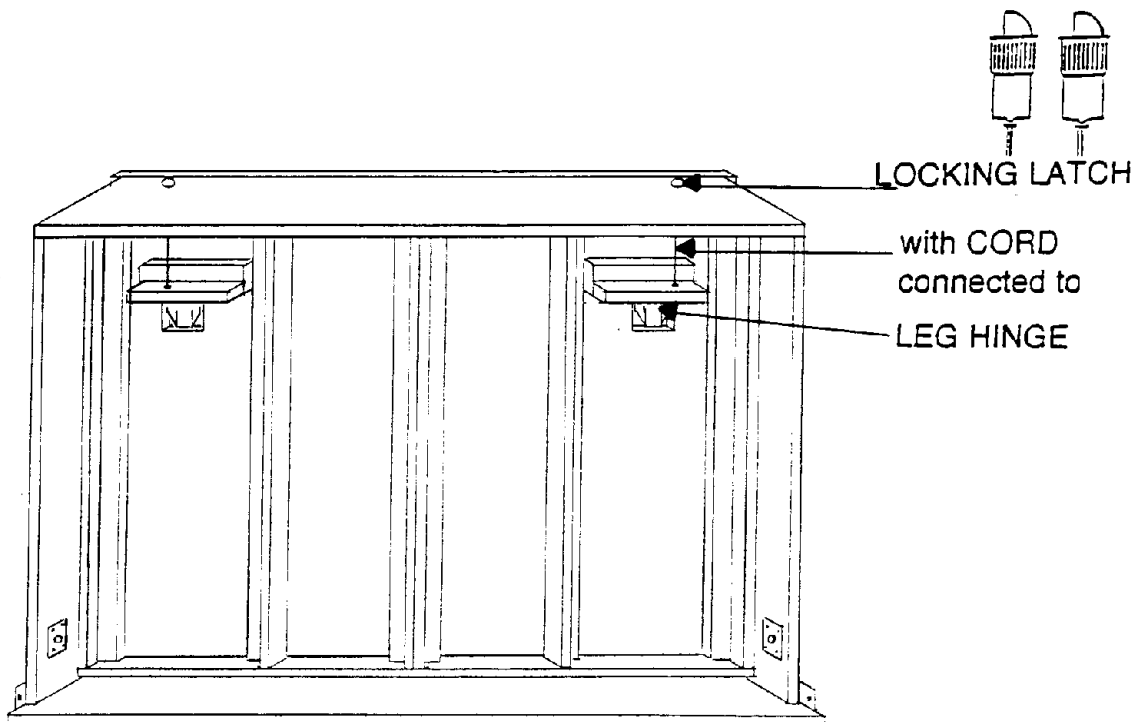

VIEW OF LEG FROM UNDERNEATH

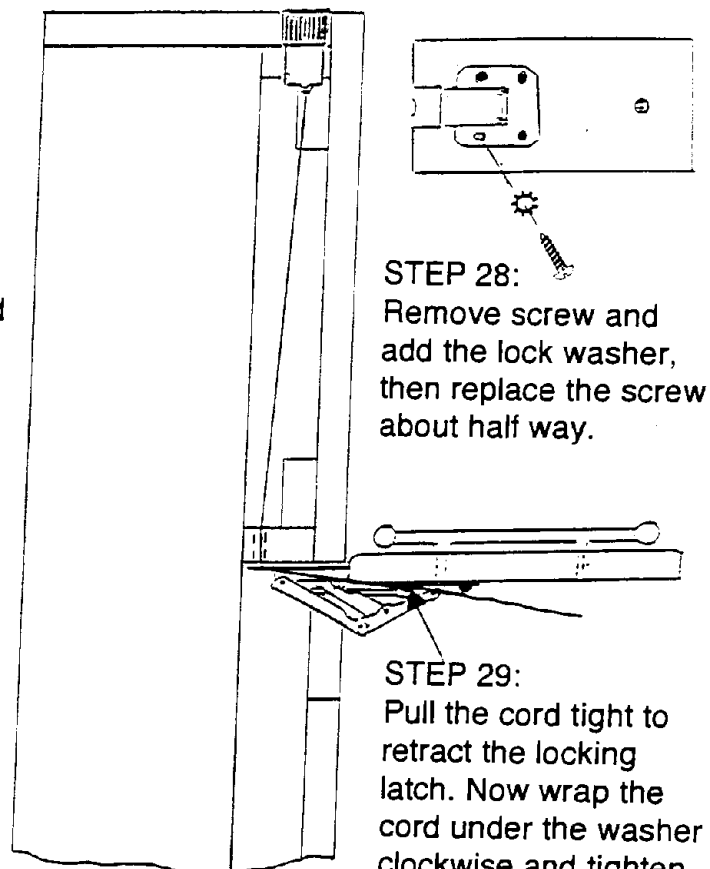
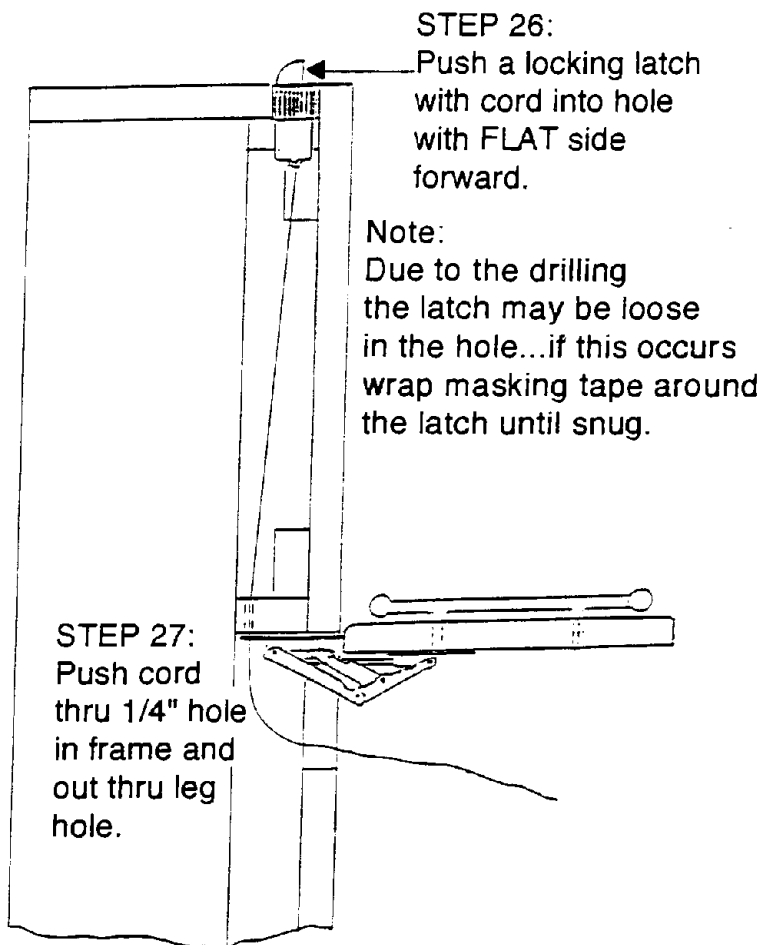

STEP 30: Open and close the leg several times to assure correct operation of the locking latch.

PART G: BED CABINET VERTICALS

Measurements for TWIN HORIZONTAL (Sidebed) ONLY
Using 3/4" PLYWOOD Face Panel.

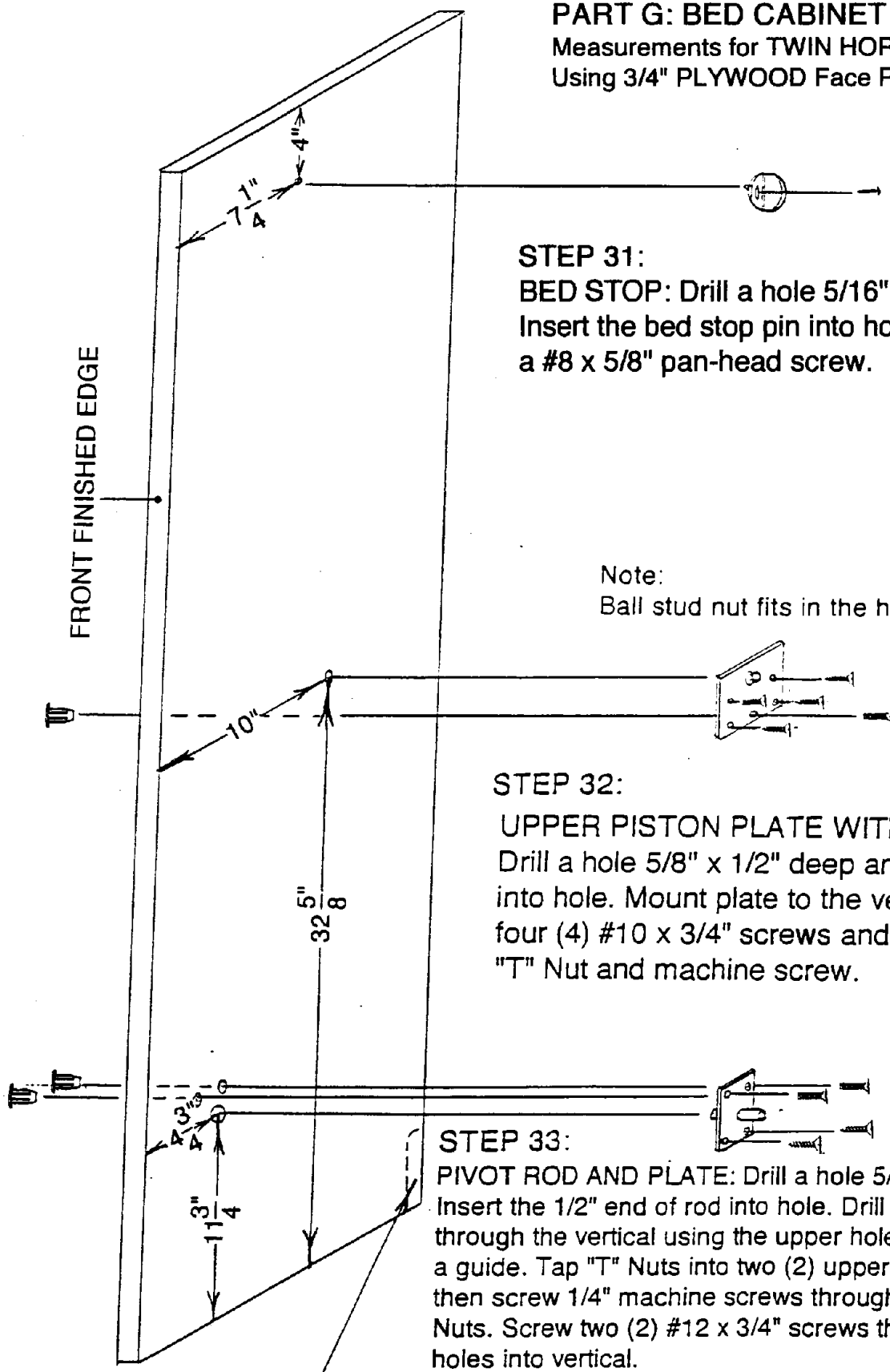

STEP 31:

BED STOP: Drill a hole 5/16" dia. x 1/2" deep
Insert the bed stop pin into hole and attach with
a #8 x 5/8" pan-head screw.

Note:

Ball stud nut fits in the hole

STEP 32:

UPPER PISTON PLATE WITH BALL STUD:
Drill a hole 5/8" x 1/2" deep and insert nut
into hole. Mount plate to the vertical with
four (4) #10 x 3/4" screws and one (1)
"T" Nut and machine screw.

STEP 33:

PIVOT ROD AND PLATE: Drill a hole 5/8" dia. x 1/2" deep.
Insert the 1/2" end of rod into hole. Drill two (2) holes 1/4" dia.
through the vertical using the upper holes in the pivot plate as
a guide. Tap "T" Nuts into two (2) upper holes from outside,
then screw 1/4" machine screws through pivot plate into "T"
Nuts. Screw two (2) #12 x 3/4" screws through pivot plate
holes into vertical.

OPTION:

On left and right bed verticals, a cut
can be made to accommodate existing
base molding so cabinet will fit flush
against the wall.

NOTE: The Left Vertical is Shown,
Repeat Steps 31, 32, and 33
For The Right Vertical.

F. BED HEADBOARD

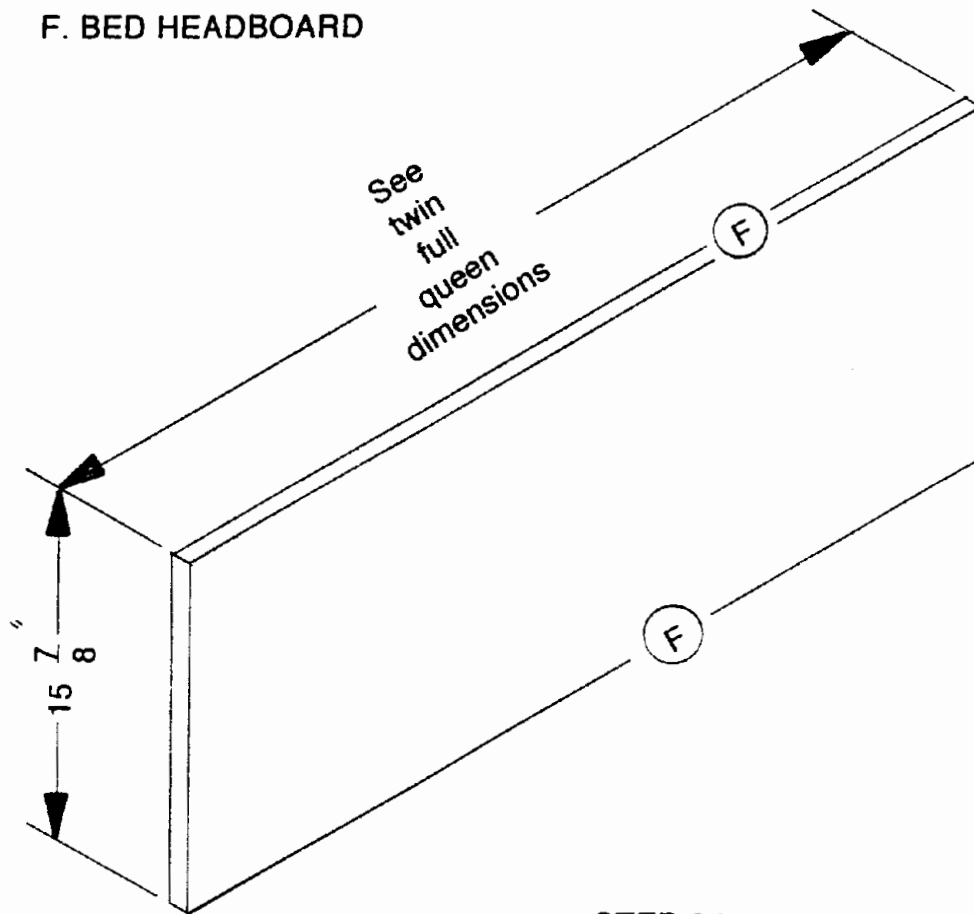

STEP 34:
NOTE: For a finished look, apply wood veneer or melamine edge tape to all edges marked **F**.

PART H: BED HEADER COMPONENTS

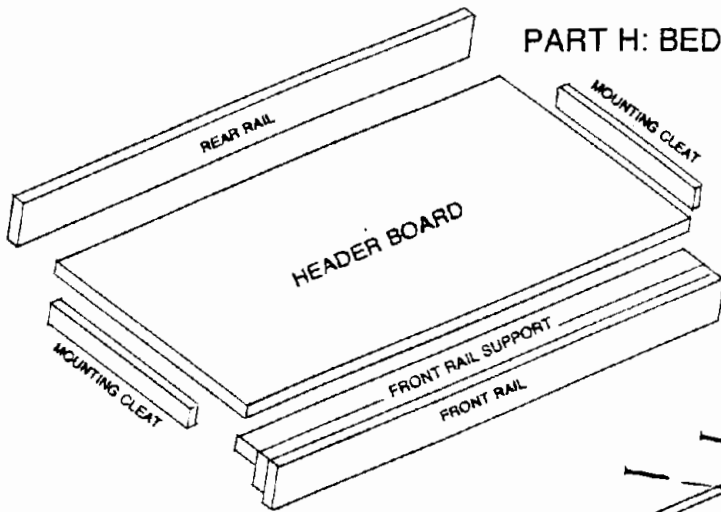

STEP 35:
Drill five (5) pilot holes through rear rail. Glue and screw rear rail to header board with #8 x 2" screws.

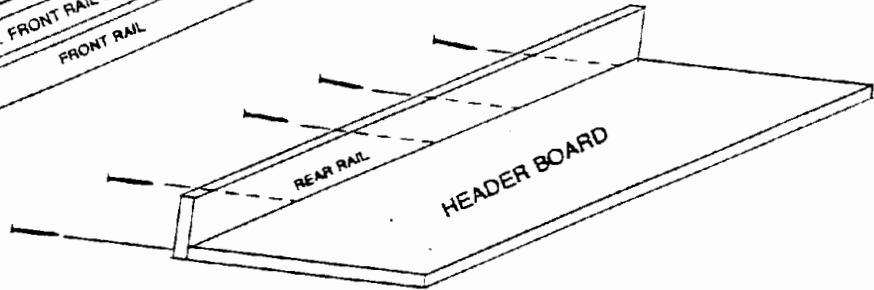

STEP 36:
Drill six (6) 1/8" pilot holes in front rail support, then glue and screw together with 1 1/2" wood screws or nails. This the same operation as performed on struts.

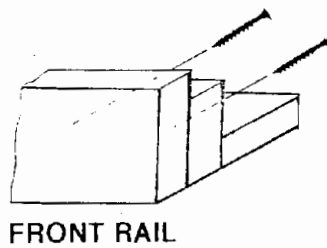

STEP 37: Attaching the front rail to the front rail support:
Drill six (6) pilot holes 1 1/4" deep through rear of support into rear of front rail, then glue and screw together with 1 1/4" wood screws.

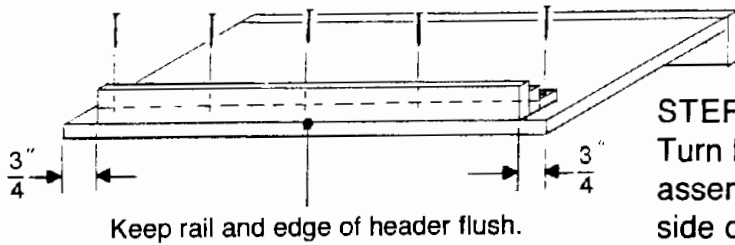

STEP 38:
Turn header board over (top down) and position assembled rail and supports 3/4" in from each side of header board. Being sure to keep rail and edge of header board flush, drill five(5) pilot holes 1 1/4" deep in front rail support into header, then glue and screw to header board with 1 1/4" wood screws.

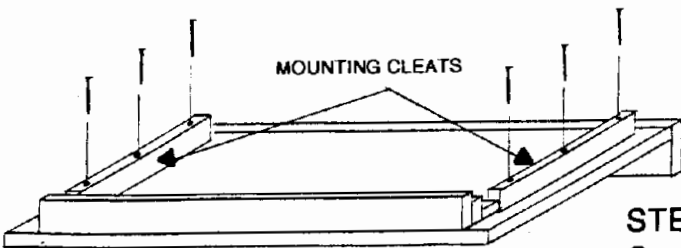

STEP 39:
Cut two (2) mounting cleats to fit between front rail and back of header board and attach to header board with 1 1/4" wood screws 3/4" from edge of header.

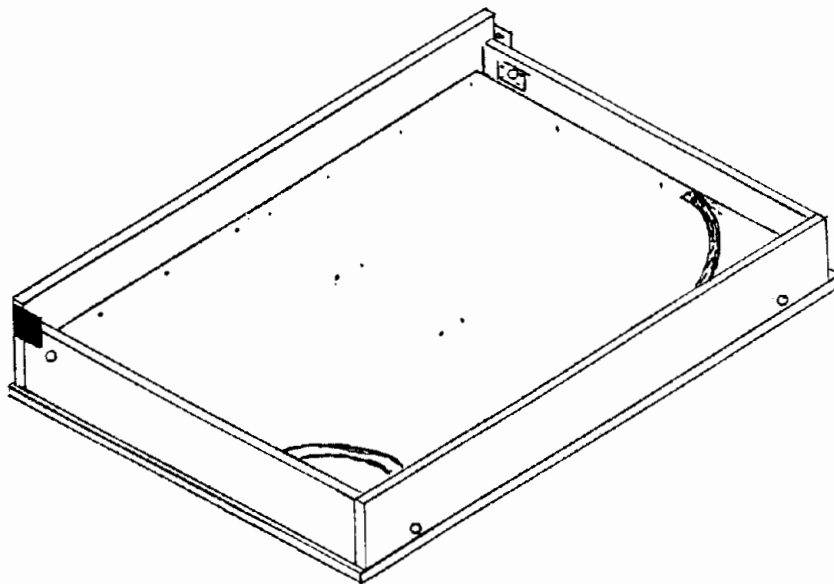
**STEP 40:**

Lay 1/4" plywood mattress support (PART J) on inner bed frame and attach with finish nails or screws. Screw ends of both mattress retaining straps thru 1/4" plywood (PART J) into inner wood bed frame, 16 (sixteen) inches from front corners of face panel as shown. Place innerspring mattress on plywood, and slip both straps over front corners of mattress, checking length to assure mattress is secure.

NOTE:

Now refer to the **BLUE ASSEMBLY BOOKLET** and **VIDEO** for instructions for assembling and installing your murphy bed.

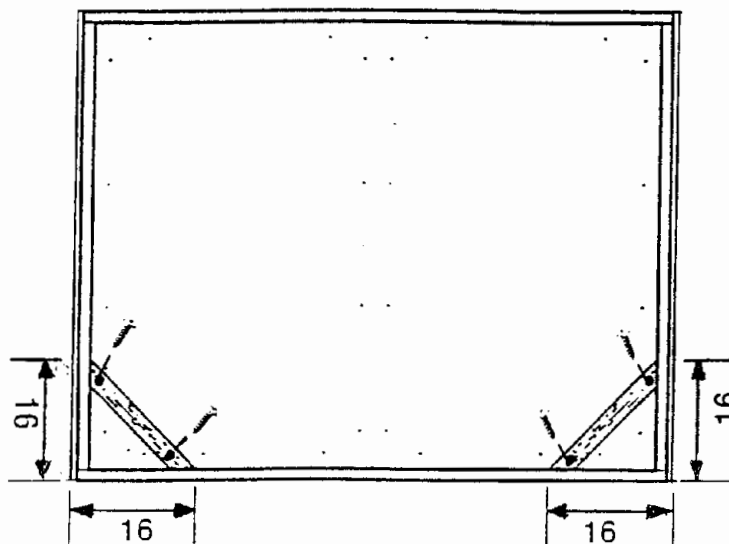

ASSEMBLY INSTRUCTIONS FOR THE
HORIZONTAL (Sidebed)

Create-A-Bed[®]

MURPHY BED

WARNING!

**This bed contains stored mechanical energy
 which can cause serious injury if improperly handled.
 Your bed **MUST! MUST!** be securely anchored to the wall!
**READ INSTRUCTIONS AND WATCH VIDEO THOROUGHLY
 BEFORE
 ASSEMBLY AND DISASSEMBLY!****

If you have ANY questions, call **TOLL FREE (877) 966-3852**

Tools needed: Power drill, Stud Finder, Tape Measure, Phillips-head screwdriver, Flat-head screwdriver and drill bits appropriate for your mounting surface see step 15 on page 7.

STEP 1

Familiarize yourself with all
COMPONENTS in Figure 1.
 Position **PARTS** in front of
 desired cabinet location.

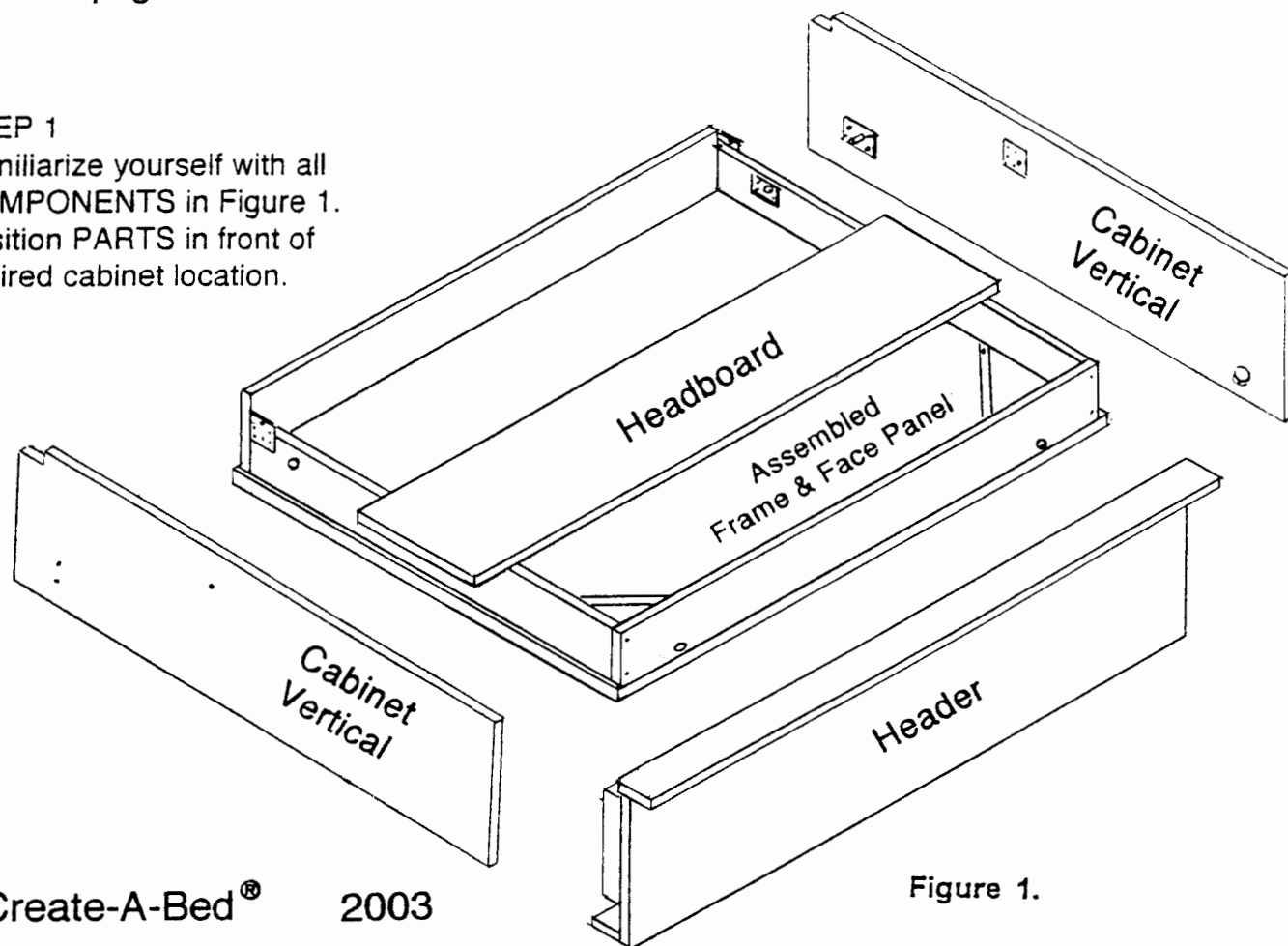
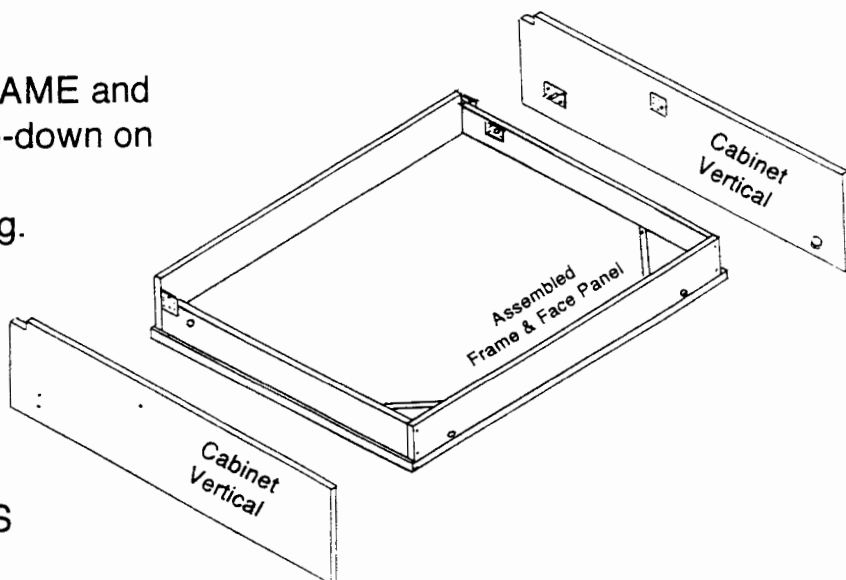

Figure 1.

STEP 2:
Lay assembled FRAME and FACE PANEL face-down on a padded surface- i.e., a blanket or rug.



STEP 3:
Lay CABINET VERTICALS on finished (front) edge as shown.

STEP 4:
Slide PLASTIC WASHERS onto PIVOT BARS.

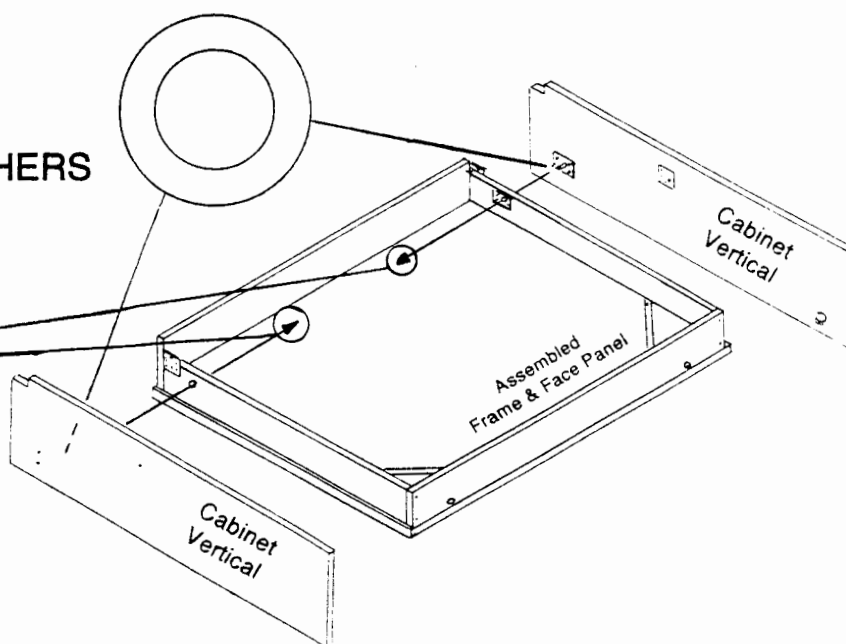

STEP 5:
Slide PIVOT BARS into PIVOT HOLES in bed frame until no gap remains between bed frame and verticals.

STEP 6:
Measure up 15" (inches) from end of vertical and screw the headboard into place as shown using #8 x 2" screws.

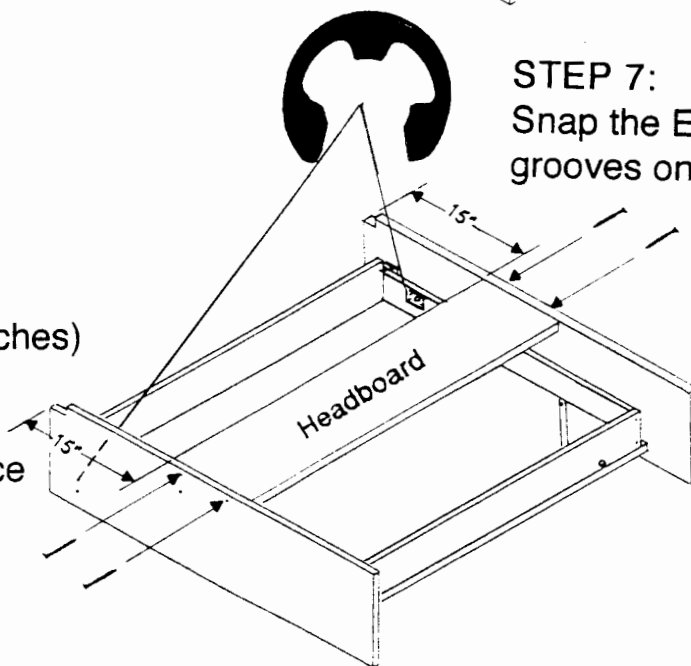

STEP 7:
Snap the E-Clips in the grooves on both pivot bars.

STEP 8:

With the **BED FACE PANEL** remaining face-down on padding, slowly and carefully rotate the **CABINET VERTICALS** & the **HEADBOARD** assembly into its upright position.

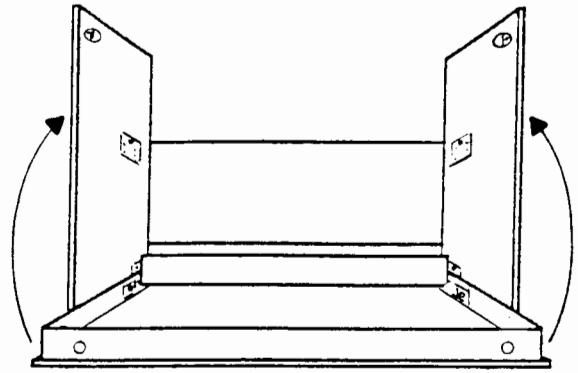

NOTE: To prevent damage to the legs be sure they are in the closed position when rotating the bed into the upright position.

STEP 9:

Place the bed header on top of the bed verticals, making sure that the rear rail is at the rear of the bed.

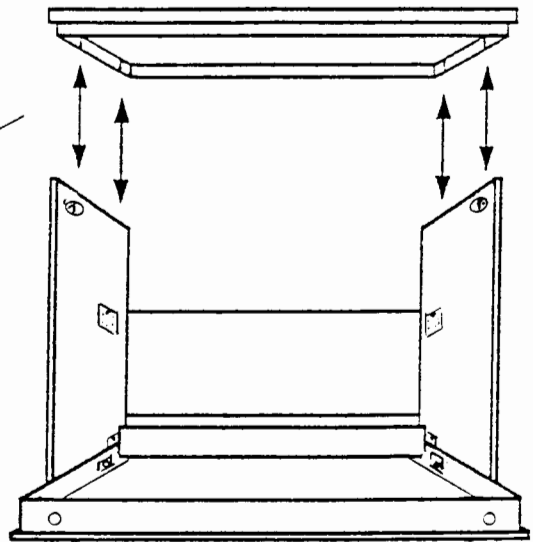

Using **#8 x 1-1/4"** screws, drill and screw through the mounting cleats into the bed verticals, three (3) on each side.

STEP 10:

Remove the two (2) bed stops from inside of bed cabinet.

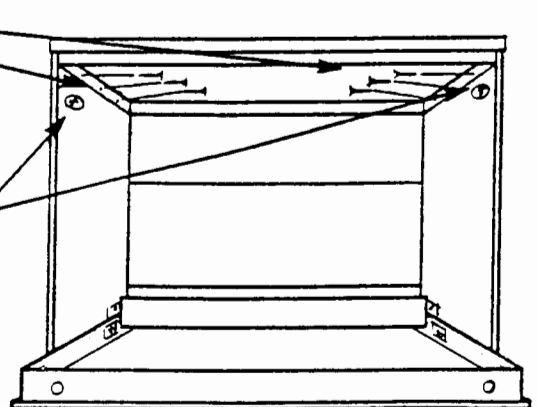

STEP 11:

Place bed cabinet 2 to 3 feet away from the wall,
allowing enough room to comfortably work behind
the bed cabinet.

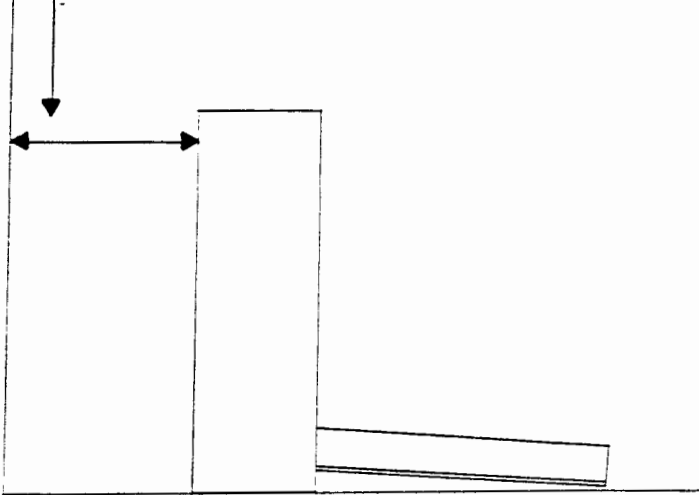
**STEP 12:**

With a helper holding the bed cabinet, allow the bed to
recess back into the cabinet about three (3) inches.

At this point, the piston can be installed. Simply snap
the piston on the bottom (bed frame) end first -
then the top (bed cabinet) end.

BE SURE TO ORIENT PISTON CORRECTLY
by referring to the label on each piston. ("MOUNT
THIS END UP")

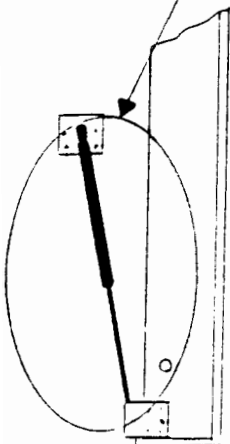

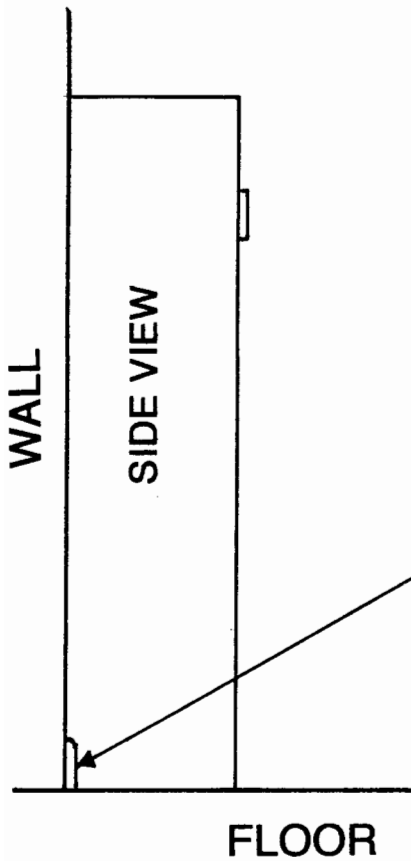
**STEP 13:**

If the room has existing base molding, make a cut at the bottom rear of the cabinet verticals to accommodate the existing base molding.

If room does not have base molding, simply place cabinet flush against wall.

STEP 14:

After assuring that the top and bottom of the bed cabinet are against the wall, center the face panel between the verticals by placing a piece of folded cardboard between the face panel and each of the two verticals as illustrated.

NOTE: The face panel is still recessed inside the cabinet.

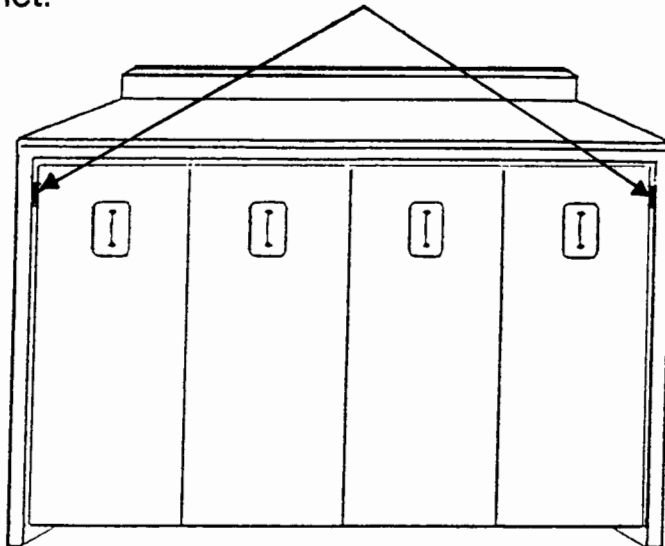

STEP 15 IS VERY, VERY IMPORTANT!!! YOUR BED MUST BE SECURELY AND CORRECTLY ANCHORED TO THE WALL to assure proper operation and to avoid possible injury.

NOTE: When the bed is lowered, it wants to pull the bed cabinet down with it, so the bed cabinet **MUST** be securely anchored to the wall using the correct fasteners for your type of wall.

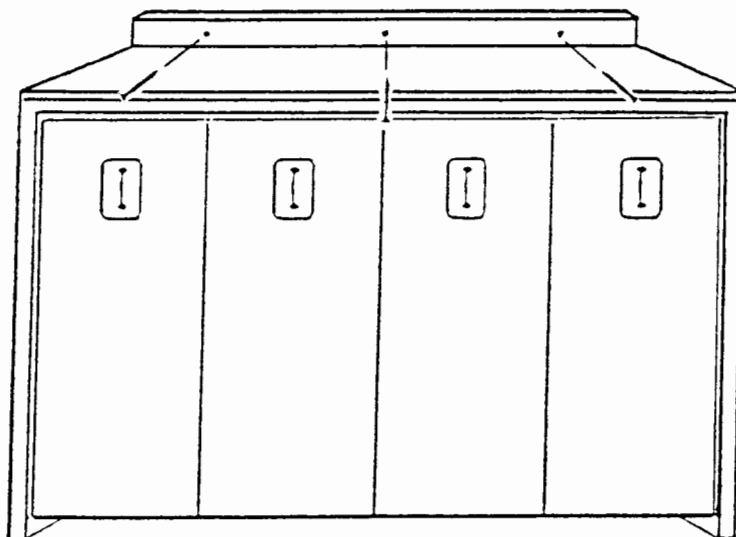

See STEP 15 on PAGE 7 for Anchoring Instructions



STEP 15: MOUNTING THE BED CABINET TO THE WALL

If the wall has **WOOD** studs, use 3" **COARSE THREAD** drywall screws or 3" lag screws:

Locate and mark the centers of the studs in desired wall location using a good studfinder.

Drill three (3) pilot holes through the rear rail of the Bed Header into the wall for a twin or full size bed and four (4) for a queen size bed.

Drive three (3) 3" drywall screws or lag screws through the rear rail of the Bed Header into the studs for a twin or full, and drive four (4) screws for a queen size bed.

If the wall is **CONCRETE, MORTAR OR BRICK** construction, use masonry screws :

Drill three (3) pilot holes through the rear rail of the Bed Header into the wall for a twin or full size bed and four (4) for a queen size bed.

Using a 5/32" 4" concrete drill bit, drill through the pilot holes into the wall two (2) inches deep. Anchor the bed by screwing 3/16" x 2 1/4" masonry screws through the rear rail of the Bed Header into the wall.

If the wall has **METAL** studs, use 3/16" x 4" toggle bolts :

Locate and mark the centers of the studs in desired wall location using a good studfinder.

Drill three (3) pilot holes through the back rail of the Bed Header into the wall for a twin or full size bed and four (4) for a queen size bed.

Using a 9/16" drill bit, drill holes at the pilot holes through the metal studs. Be sure you drill through the studs. Insert the toggle bolt screws through the pilot holes in the rear rail of the Bed Header. Now thread the toggle wings on the screws. Fold the wings back completely and push the wings through the metal studs until the wings spring open. Pull the Header Rail back to hold the wings against the inside of the stud and tighten the screws with a screwdriver.

STEP 16:

Holding the BED FACE PANEL in the down position, place the innerspring mattress on the bed and secure with ELASTIC RETAINING STRAPS.

NOTE: When lowering the bed without the counter balance of the mattress it may seem very difficult... do not be concerned, once the mattress is placed on the bed it will function easily.

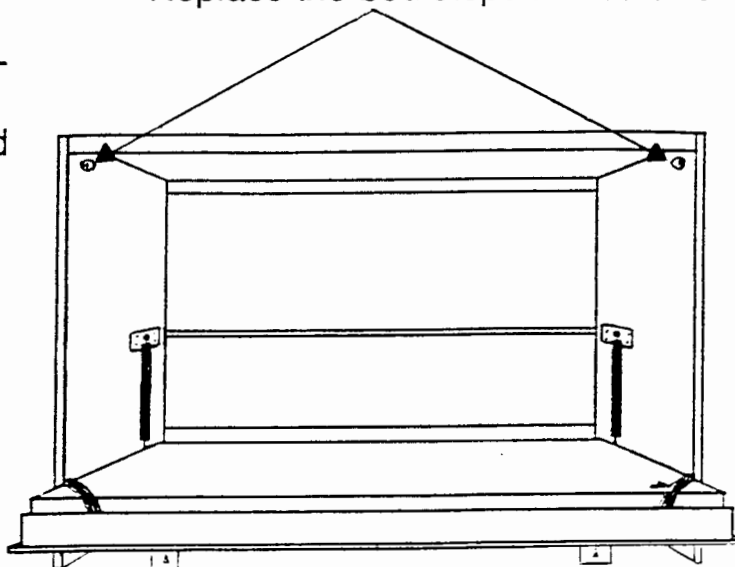

If the mattress is lightweight and the bed has a tendency to float off the floor, simply add some weight-i.e.- a piece of particle board, wood, etc. inside the bed frame at the end of the bed to counter-balance.

Narrowest Gap

STEP 18:

Close bed. If the gap around the bed is uneven, push or gently kick the base of the CABINET on the side with the NARROWEST gap until desired gap is obtained.

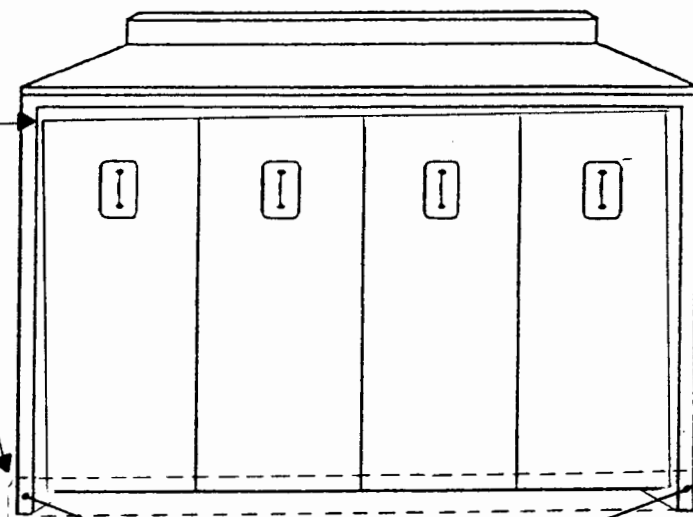
**STEP 19:**

Close the bed. Apply base molding (if applicable) from outside of vertical to outside of vertical.

PROBLEM SOLVING

Q: The piston won't hand-compress... has it "frozen up?"

A: The design and construction of the piston's internal parts won't allow it to "freeze up." Each piston contains as much as 240 pounds of pressure, so they **CANNOT** be compressed by hand. Please refer to the **ASSEMBLY BOOKLET**, page 4 - step 12.

Q: The bed is very hard to open and it wants to spring closed.

A: Your mechanism is designed to have the optimum mechanical leverage to comfortably raise and lower the bed.
Place the mattress on the bed. The mattress is the counter-balance, i.e., This is what offsets the force of the piston.

Q: I've assembled the bed and attached it to the wall, but the bed face panel sags out of the cabinet... what do I do now?

A: The mounting positions of the upper or the lower ball stud plates are incorrect. Check your measurements on **PAGES 9, 10 and 20**. Remember... the measurements in the white (particle board) book **ARE DIFFERENT** from the measurements in the yellow (plywood) book.
IF the face panel sags out of the cabinet and you **FORCE** it closed you will damage the head of the piston.

DO NOT ATTEMPT To Compress the piston by any other means than the one described in the steps below.

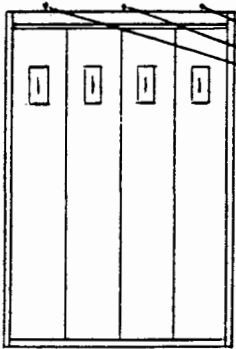

1. With the bed in the upright, closed position with both legs closed and locked, remove the anchor screws from the top of the bed cabinet. Do not remove the anchor screws with the bed in the open position.

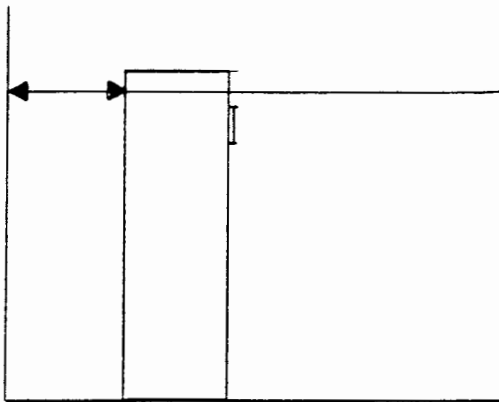

2. Place the bed cabinet 2 to 3 feet away from the wall, allowing enough room to comfortably work behind the bed cabinet.

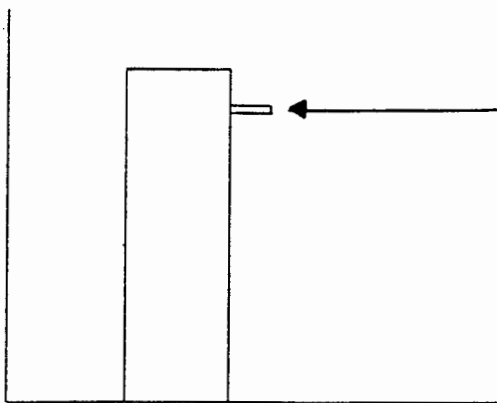

3. With a helper **SECURELY** holding the bed cabinet, lift both locking legs to unlock the bed from the cabinet.

4. With the helper **CONTINUING TO HOLD** the bed cabinet, lower the bed 4 to 5 inches out of the cabinet.

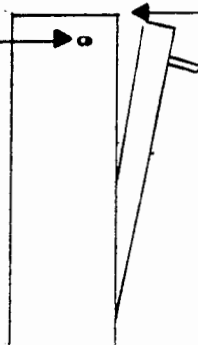
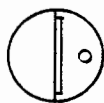

5. Working from the back of the bed, remove the screws and brass bed stops.

6. With your helper **STILL HOLDING THE BED CABINET**, allow the bed to pull back into the bed cabinet. It will recess about 3 inches into the bed cabinet.

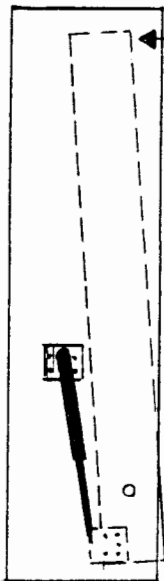

7. At this point, the piston can be removed and replaced **ONE AT A TIME**.

8. With the tension off of the piston - i.e. - with the piston fully extended and using a flat blade screwdriver, gently pry up on the spring clip located around the plastic head of the piston. Now just pull the piston off - **REMEMBER** the spring clip isn't removed, just opened.

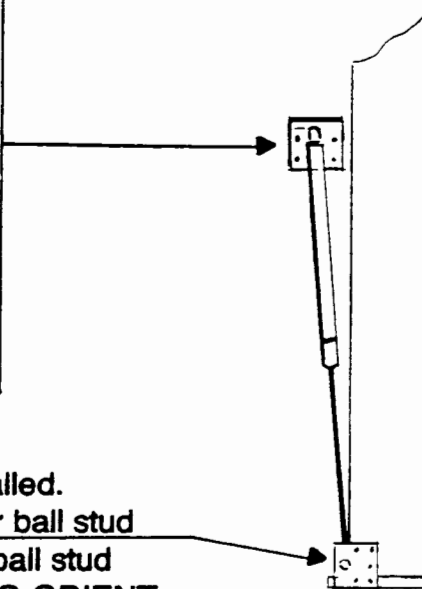
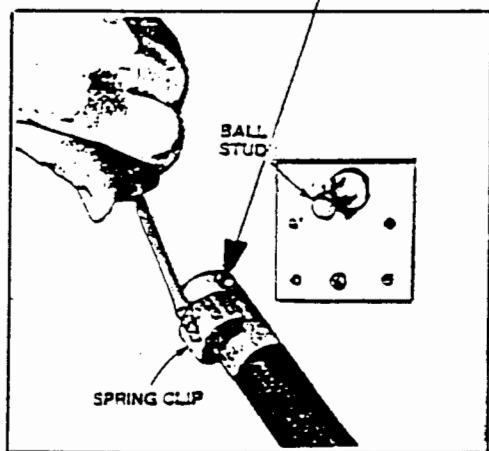

9. At this point, the new piston can be installed. Simply snap the new piston on the lower ball stud located on the bed rail - then the upper ball stud located on the bed vertical. **BE SURE TO ORIENT THE PISTON CORRECTLY** by referring to the label on the piston. (**MOUNT THIS END UP**)
10. Repeat on the other side of the bed.
11. Replace both bed stops and screws.
12. Place the bed cabinet back against the wall and replace the screws, **MAKING SURE THE BED IS SECURELY FASTENED TO THE WALL.**