

DO NOT DEVIATE FROM THESE PLANS!

**If you want to modify these plans IN ANY
WAY, please CALL US FIRST toll-free:**

1-877-966-3852

**Unapproved changes can cause your
Murphy bed to NOT WORK CORRECTLY
and will VOID your warranty.**

PLEASE NOTE:

**This kit is engineered to work with
ANY mattress that meets
these WEIGHT and THICKNESS
specifications:**

<u>SIZE OF BED</u>	<u>THICKNESS (including any pillow top)</u>	<u>WEIGHT</u>
TWIN	Up to 12 inches	35 to 50 pounds
FULL	Up to 12 inches	50 to 65 pounds
QUEEN	Up to 12 inches	65 to 80 pounds

Create-A-Bed® *LLC*

NOTE: DO NOT deviate from these plans

These plans are for constructing an
ADJUSTABLE

FULL VERTICAL BED

using **PLYWOOD** material

If you are missing any parts or have ANY questions pertaining to materials or construction please phone the manufacturer.

TOLL FREE 1-877-966-3852

TOOLS NEEDED:

Power Drill

Drill Bits: 1/8" 1/4" 5/16", 1" Forstner Bit, 5/8" Forstner Bit
3/4" Forstner Bit

Power Saw, Table Saw or Circular Saw

Jigsaw or Coping Saw

Phillips-Head and Flat-Head Screwdrivers or Driver Bits for Drill

Tape Measure

#4 Allen Wrench

Hammer

Chisel

Clamps

Straight Edge or Framing Square

Household Iron for Veneer Tape and Utility Knife

7/16" Socket, Wrench, or Driver

1/2" Wrench

Stud Finder

© *Create-A-Bed*® 2014, 2017, 2018, 2021

murphy bed mechanism

1800 Taylor Avenue Louisville, KY 40213

www.createabed.com

TOLL FREE: 1-877-966-3852

Create-A-Bed®

C.A.B., LLC

FULL VERTICAL (UPRIGHT) murphy bed mechanism PLYWOOD CONSTRUCTION

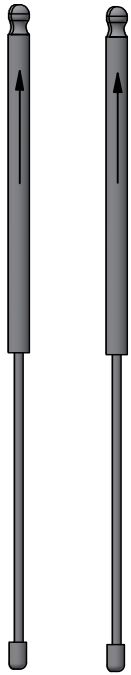

Two (2) GAS SPRINGS

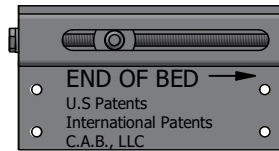
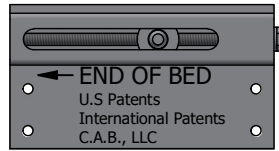

Two (2) ADJUSTABLE LOWER PLATES
with Four (4) #10 x 1-5/8" screws
Four (4) "T" nuts with machine screws



Two (2) ADJUSTABLE UPPER PLATES with
Four (4) "T" NUTS with MACHINE screws
Two (2) BALL STUDS
Two (2) BLACK BALL STUD SPACERS



Two (2) BED STOPS with Two
(2) #10 x 3/4" black screws



Two (2) ELASTIC MATTRESS
RETAINING STRAPS

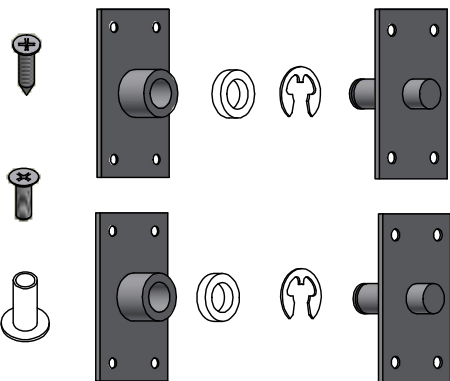

Two (2) pair of METAL PIVOTS
with Two (2) plastic spacers
Two (2) "E" CLIPS
Four (4) "T" nuts with machine screws
Twelve (12) #12 x 3/4" silver screws

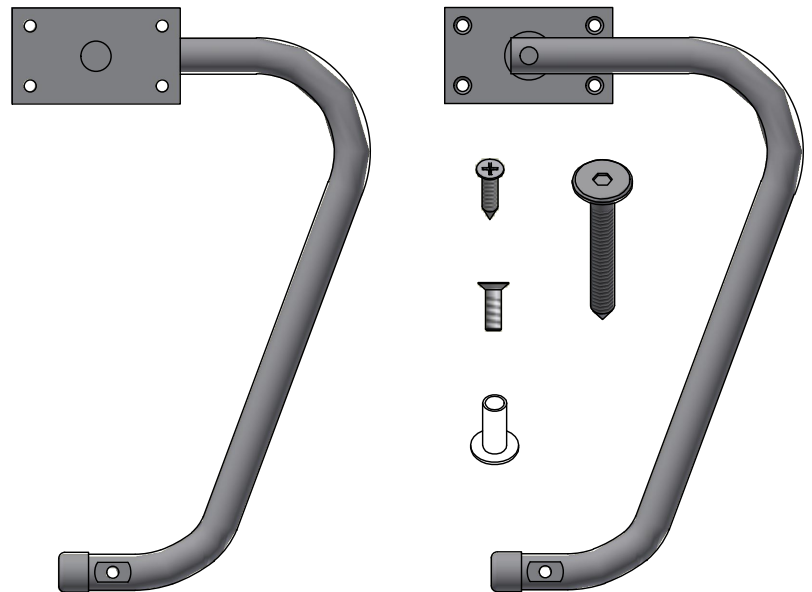

Two (2) Metal Pivoting Legs
Two (2) 1/4" x 2" Leg Support Rail screws
Four (4) Black #10 x 3/4" screws
Four (4) "T"nut with machine screws

One (1) CONSTRUCTION booklet
One (1) ASSEMBLY AND INSTALLATION booklet
Online Video: <https://bit.ly/AdjustableVertical>

Protected By U.S. Patents #8,850,637, #8,898,831
Protected By Canada Patents #2,871,969, #2,897,339
Protected By China Patent #ZL 201380032662.0
Protected By Mexico Patent #351674

Out-to-out dimensions of **VERTICAL STYLE** murphy bed cabinet constructed using the *Create-A-Bed*[®] mechanism

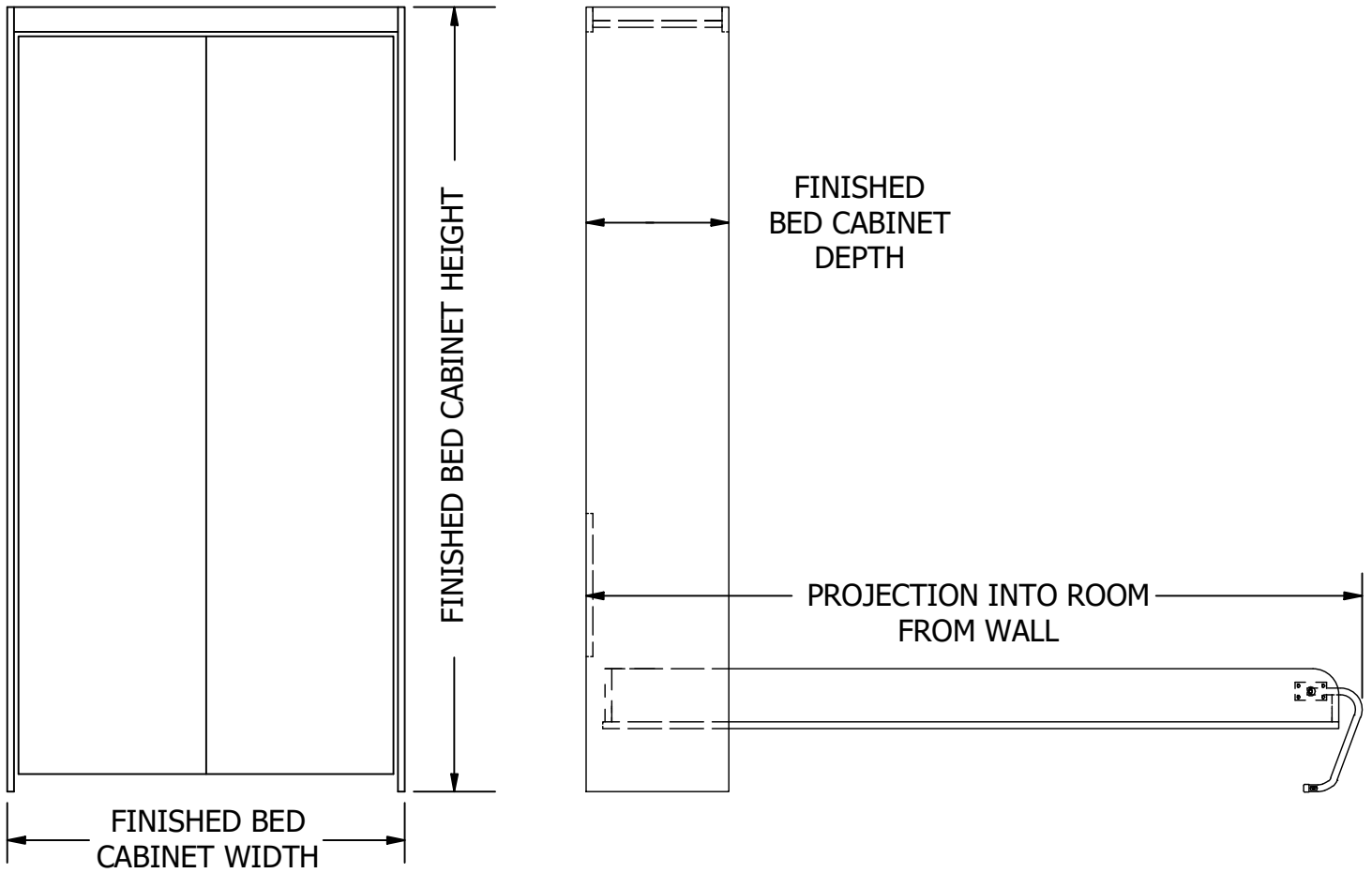

OUTSIDE-EDGE TO OUTSIDE-EDGE
FINISHED VERTICAL BED CABINET DIMENSIONS

SIZE	HEIGHT	WIDTH	DEPTH	PROJECTION
TWIN	82-1/8"	44-7/8"	15-7/8"	83"
FULL	82-1/8"	59-7/8"	15-7/8"	83"
QUEEN	87-1/8"	65-7/8"	15-7/8"	87"

Some design options... or create your own!

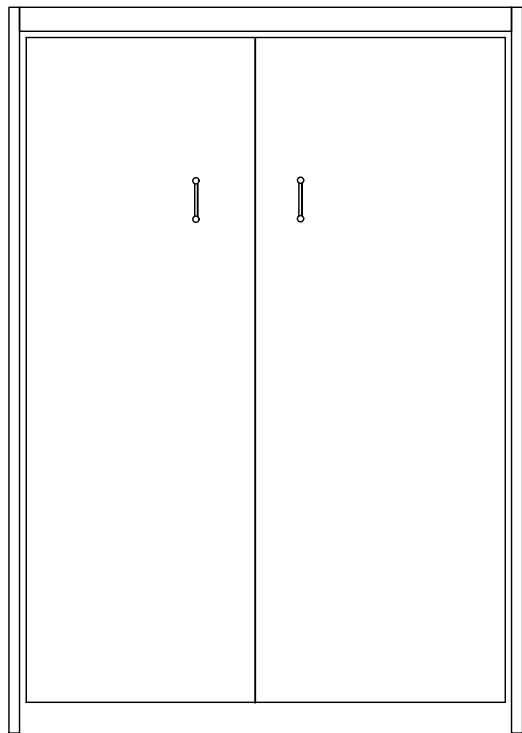

BASIC BED

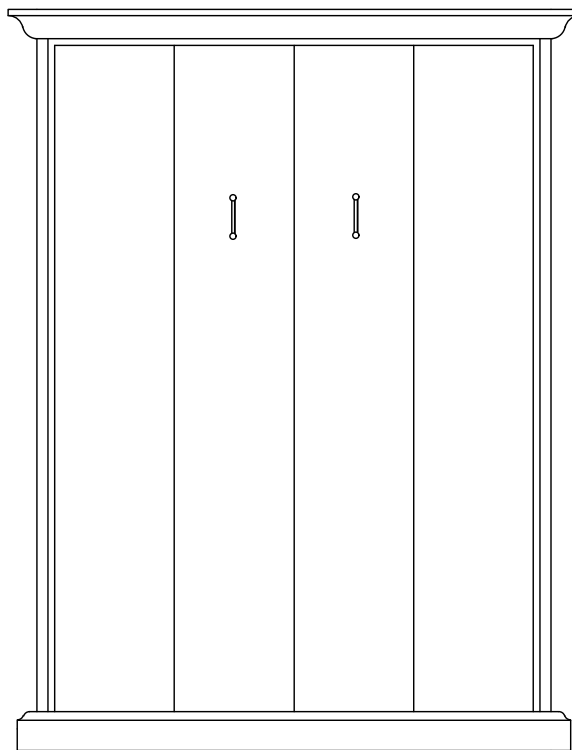

WITH CROWN
AND BASE MOLDING

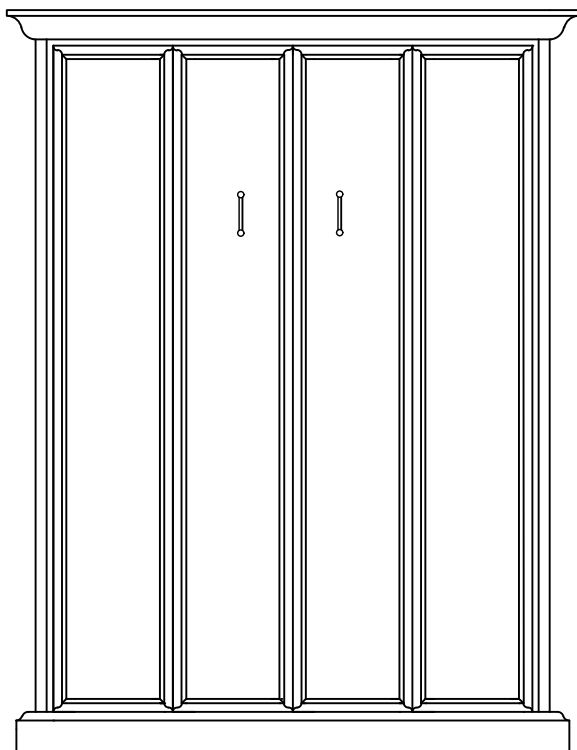

WITH CROWN, BASE
AND FULL-LENGTH FACE
PANEL MOLDING

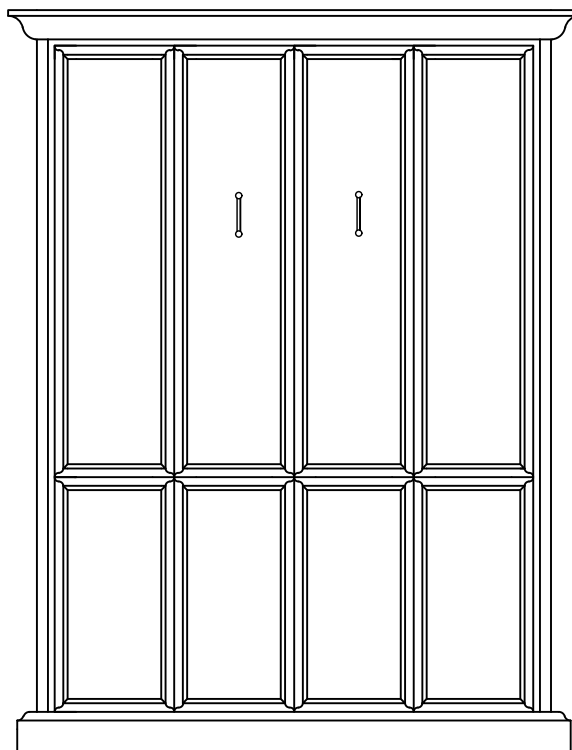

WITH CROWN, BASE
AND SPLIT
FACE PANEL MOLDING

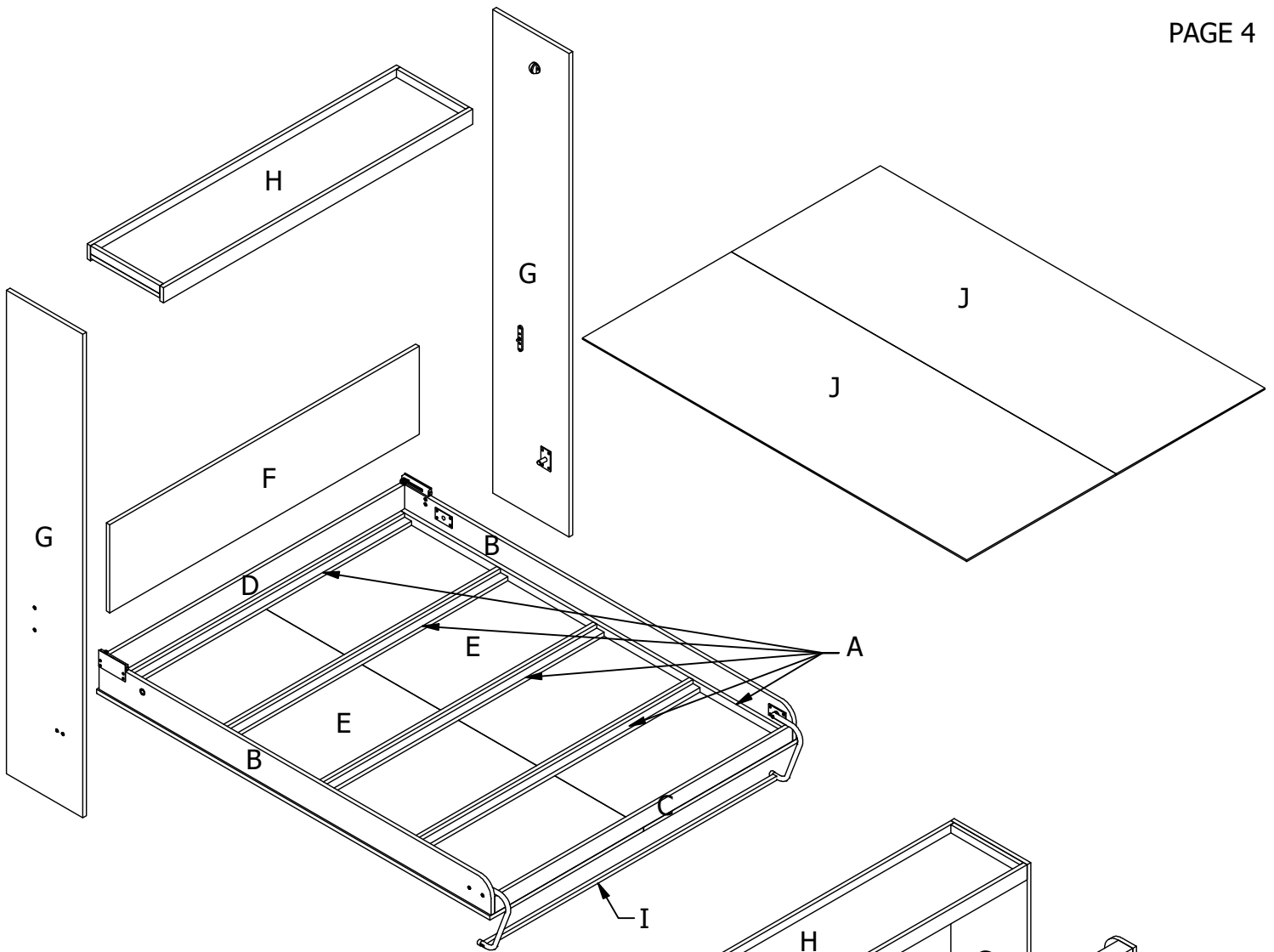

COMPONENTS OF FINISHED MURPHY BED

- A. INNER WOOD BED FRAME
- B. SIDE RAILS
- C. FOOT RAIL
- D. HEAD RAIL
- E. BED FACE PANELS
- F. BED HEADBOARD
- G. BED CABINET VERTICALS
- H. BED HEADER
- I. LEG SUPPORT RAIL
- J. 1/4" PLYWOOD MATTRESS SUPPORT

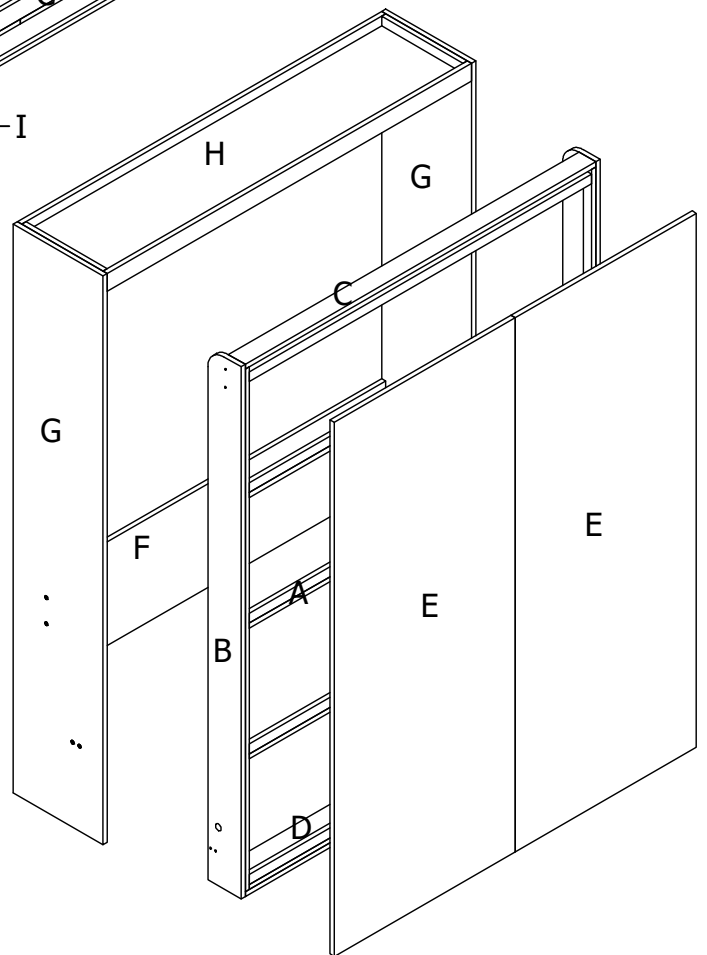

FULL Size Vertical Plywood Cutting Guide

Requires: 4 sheets of 3/4" x 4' x 8' and 2 sheets of 1/4" x 4' x 8'

NOTE: Refer to page 6 for the cutting dimensions.

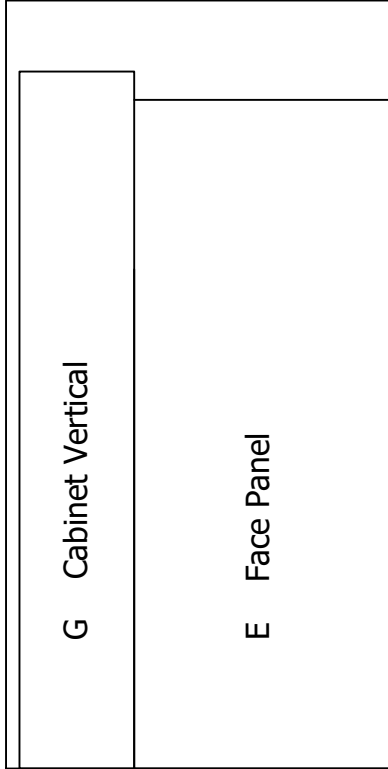

Requires 2 sheets 3/4"

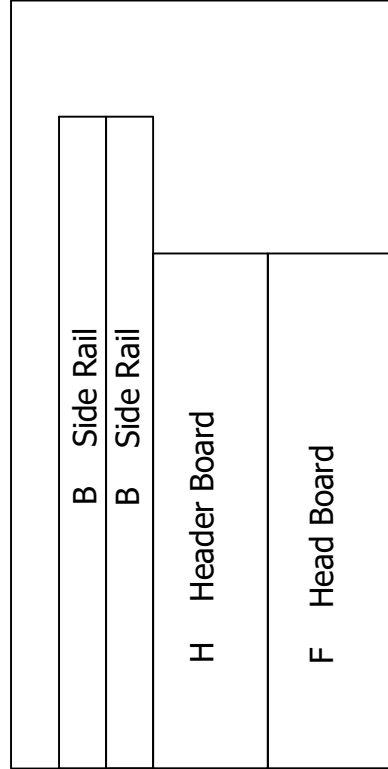

Requires 1 sheet 3/4"

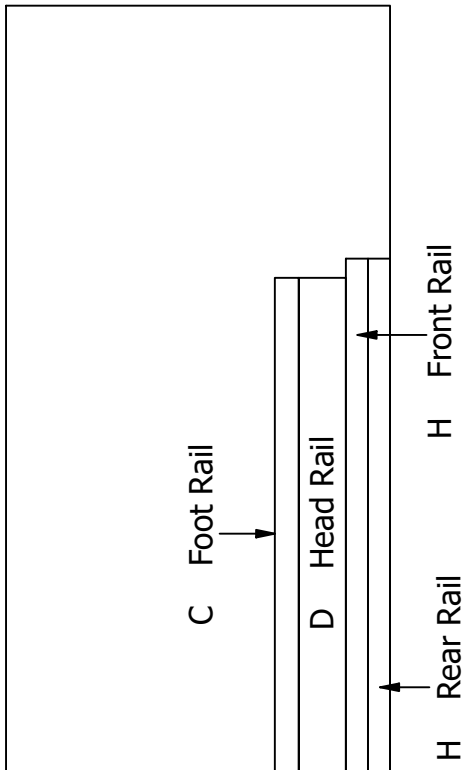

Requires 1 sheet 3/4"

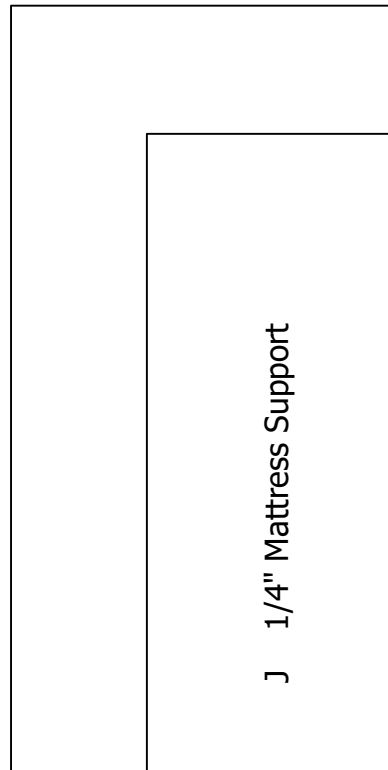

Requires 2 sheets 1/4"

FULL SIZE (double) ADJUSTABLE KIT VERTICAL BED WITH 3/4" PLYWOOD FACE PANEL
BILL OF MATERIALS / CUT SHEET

DO NOT SUBSTITUTE OTHER MATERIALS without calling Create-A-Bed toll-free FIRST

__ check off as completed

__ A. INNER WOOD BED FRAME: *To be constructed of solid wood: poplar, clear pine, maple, etc.*
 FRAME STRUTS: ***SOLID WOOD*** 3/4" X 1-1/2" X 54-1/2" 10 pieces
 FRAME SIDES: ***SOLID WOOD*** 3/4" X 1-1/2" X 75" 2 pieces

IMPORTANT: PLYWOOD MUST BE USED FOR THESE PIECES:

__ B. SIDE RAILS: **3/4" X 5-7/8" X 76-1/2"** 2 pieces

__ C. FOOT RAIL: 3/4" X 3" X 56" 1 piece

__ D. HEAD RAIL: 3/4" X 7-7/8" X 56" 1 piece

__ E. BED FACE PANEL: 3/4" X 29" X 76-3/4" 2 pieces

__ F. BED HEADBOARD: 3/4" X 15-7/8" X 58-3/8" 1 piece

__ G. BED CABINET VERTICALS: 3/4" X 15-7/8" X 82-1/8" 2 pieces

__ H. BED HEADER:
 HEADERBOARD: 3/4" X 14-3/8" X 58-3/8" 1 piece
 FRONT RAIL: 3/4" X 2-3/4" X 58-3/8" 1 piece
 REAR RAIL: 3/4" X 2-3/4" X 58-3/8" 1 piece
 MOUNTING CLEATS:***SOLID WOOD*** 3/4" X 1-1/2" X 14-3/8" 2 pieces

__ I. Leg Support Rail:***SOLID WOOD*** 3/4" X 3/4" X 54-1/4" 1 piece

__ J. 1/4" **PLYWOOD** mattress support: 1/4" X 28" X 75" 2 pieces

__ K. VENEER or MELAMINE TAPE: 13/16" X 75 feet

__ L. WOOD GLUE: One 8 ounce bottle

__ M. FINISH NAILS: 1-1/2" box of 50
 2" box of 25

__ N. SCREWS: #8 1-1/4" coarse thread Box of 100
 #8 1-1/2" coarse thread Box of 30
 #8 2" coarse thread Box of 40

__ O. DESIRED CABINET HANDLES OR PULLS 2 HANDLES

__ P. MATTRESS **MATTRESS MUST WEIGH between 50 - 65 pounds**
Your mattress dimensions must not exceed 54" x 75"
Mattress thickness CANNOT exceed 12" in thickness – including pillow top.

A. INNER WOOD BED FRAME

See Bill of Materials / Cut Sheet (PART A) for Twin, Full or Queen size frame struts and frame sides dimensions.

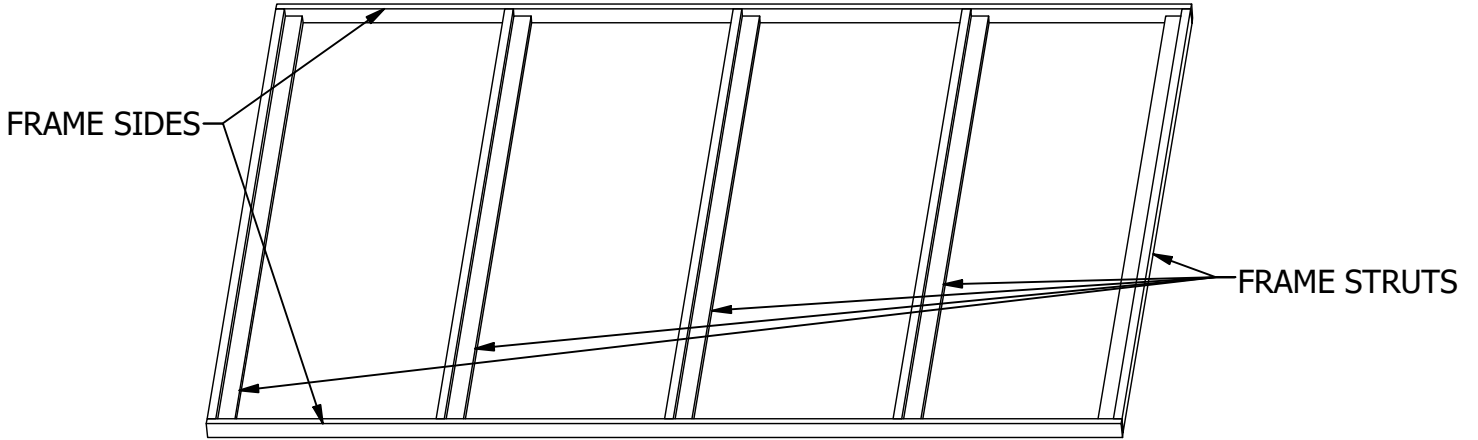

STEP 1: Construction of five (5) frame struts.

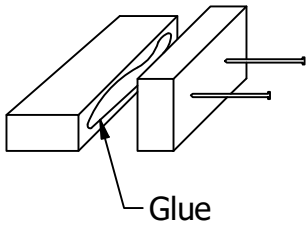

Run a bead of wood glue along inside edge. Making sure ends are flush, drill pilot holes approximately 8" apart and nail with 1-1/2" finish nails, or you can use #8 x 1-1/2" screws.

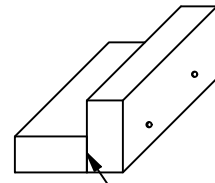

End are flush.

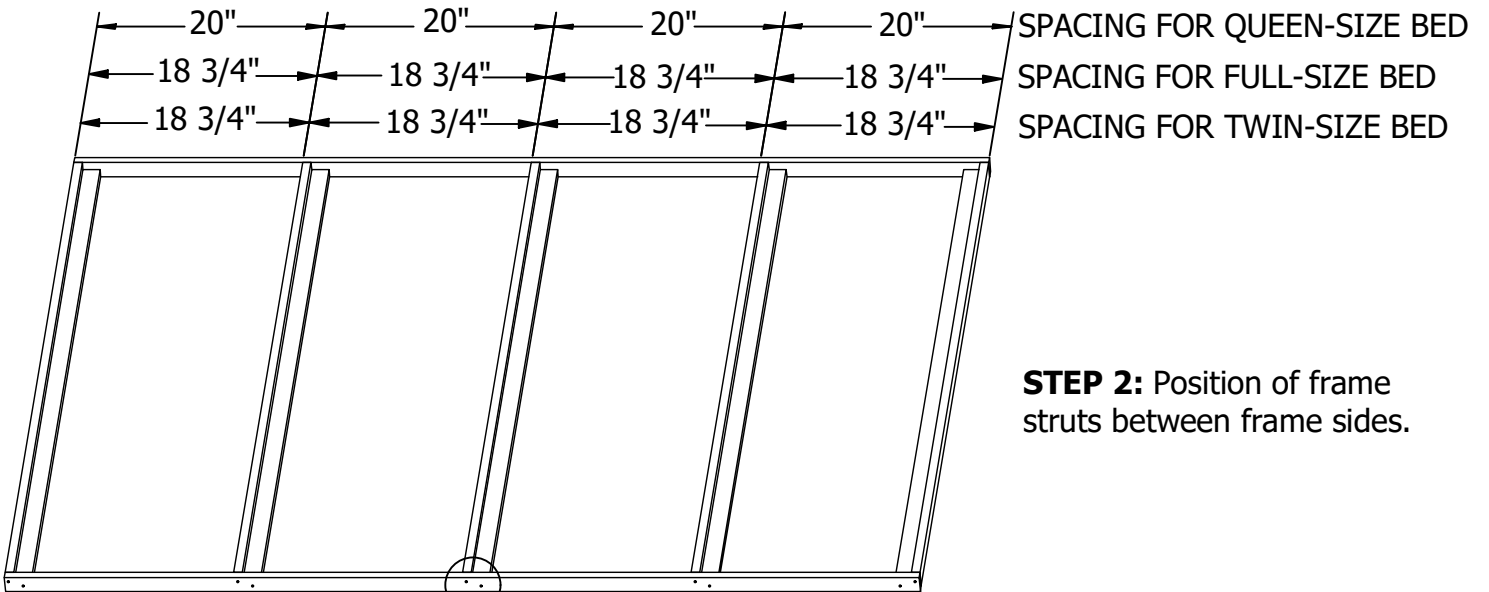

STEP 2: Position of frame struts between frame sides.

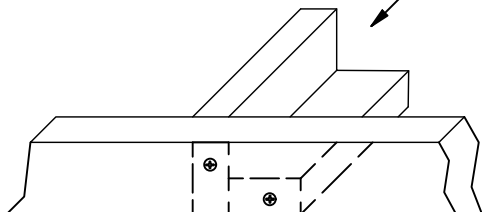

STEP 3: Mounting the frame struts between the frame sides. Using a 1/8" drill bit and countersink, drill pilot holes through the frame side into each end of the "L" shaped frame struts. Screw #8 x 2" wood screw flush.

PART B. Side Rails: **MUST BE MADE OF PLYWOOD**

Why? This is where the stress takes place. Plywood is stronger than solid wood. YES EVEN SOLID OAK....

PART C. Foot Rail
PART D. Head Rail

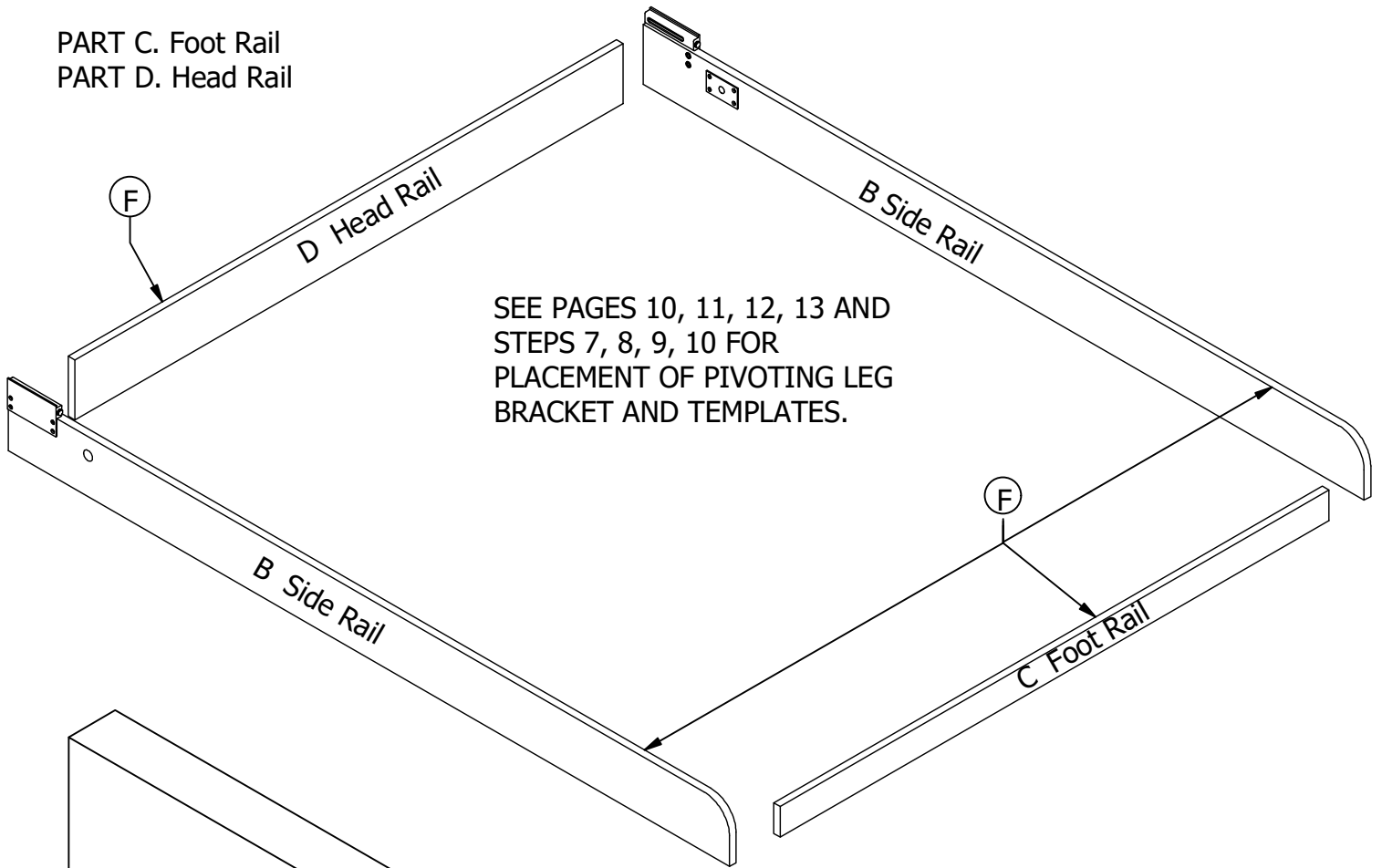

For a finished look, apply wood veneer or melamine edge banding tape to all edges marked **F**

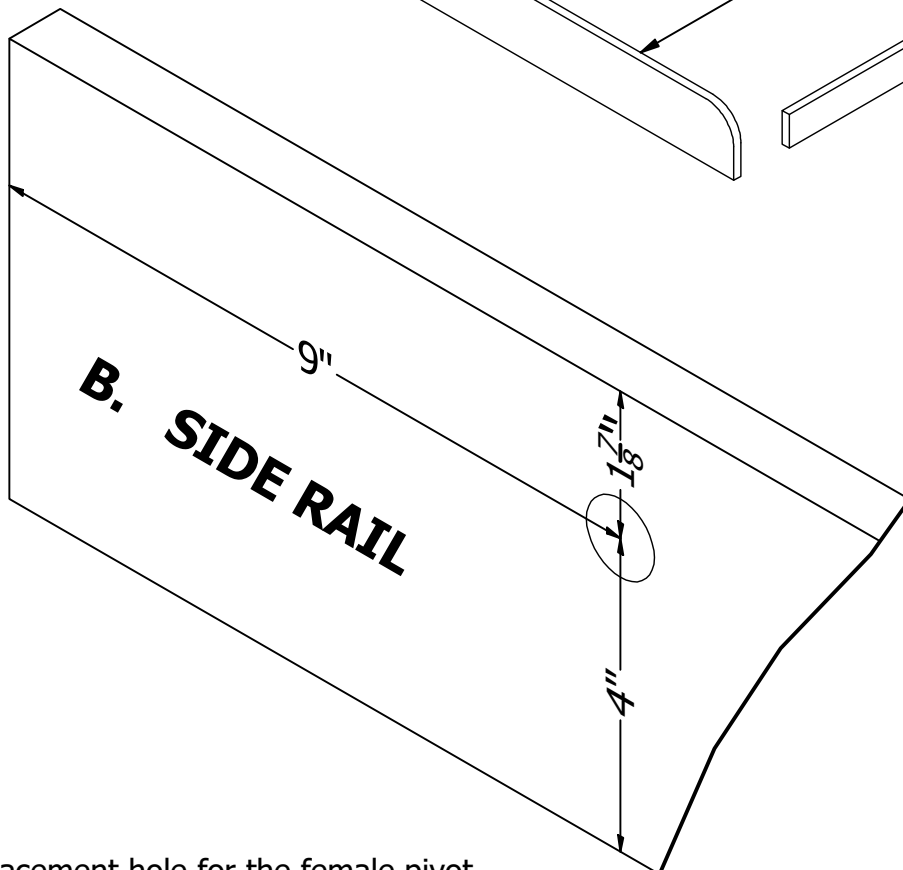

Placement hole for the female pivot
(also shown on pages 15 and 16)

HARDWARE PLACEMENT FOR B. SIDE RAILS

STEP 5: SEE PAGES 14, 15, 16, 17 AND STEPS 11, 12, & 13 FOR PLACEMENT OF **FEMALE PIVOT AND ADJUSTABLE LOWER BALL STUD PLATES.**

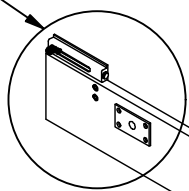

B. RIGHT SIDE RAIL

STEP 4: SEE PAGES 10, 11, 12, 13 AND STEPS 7, 8, 9, 10 FOR PLACEMENT OF **PIVOTING LEG BRACKET AND TEMPLATES.**

B. LEFT SIDE RAIL

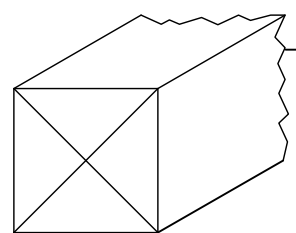
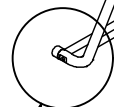
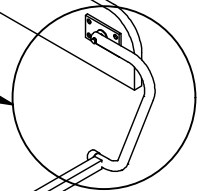

STEP 6: PART I. LEG SUPPORT RAIL SEE PAGE 6 FOR CUTTING DIMENSIONS.

ON EACH END OF RAIL DRAW AN **X** DIAGONALLY FROM EACH CORNER TO FIND THE CENTER.

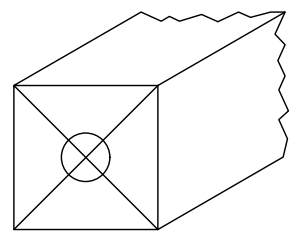

NEXT DRILL A 1/4" HOLE X 1-1/2" DEEP IN EACH END OF THE RAIL.

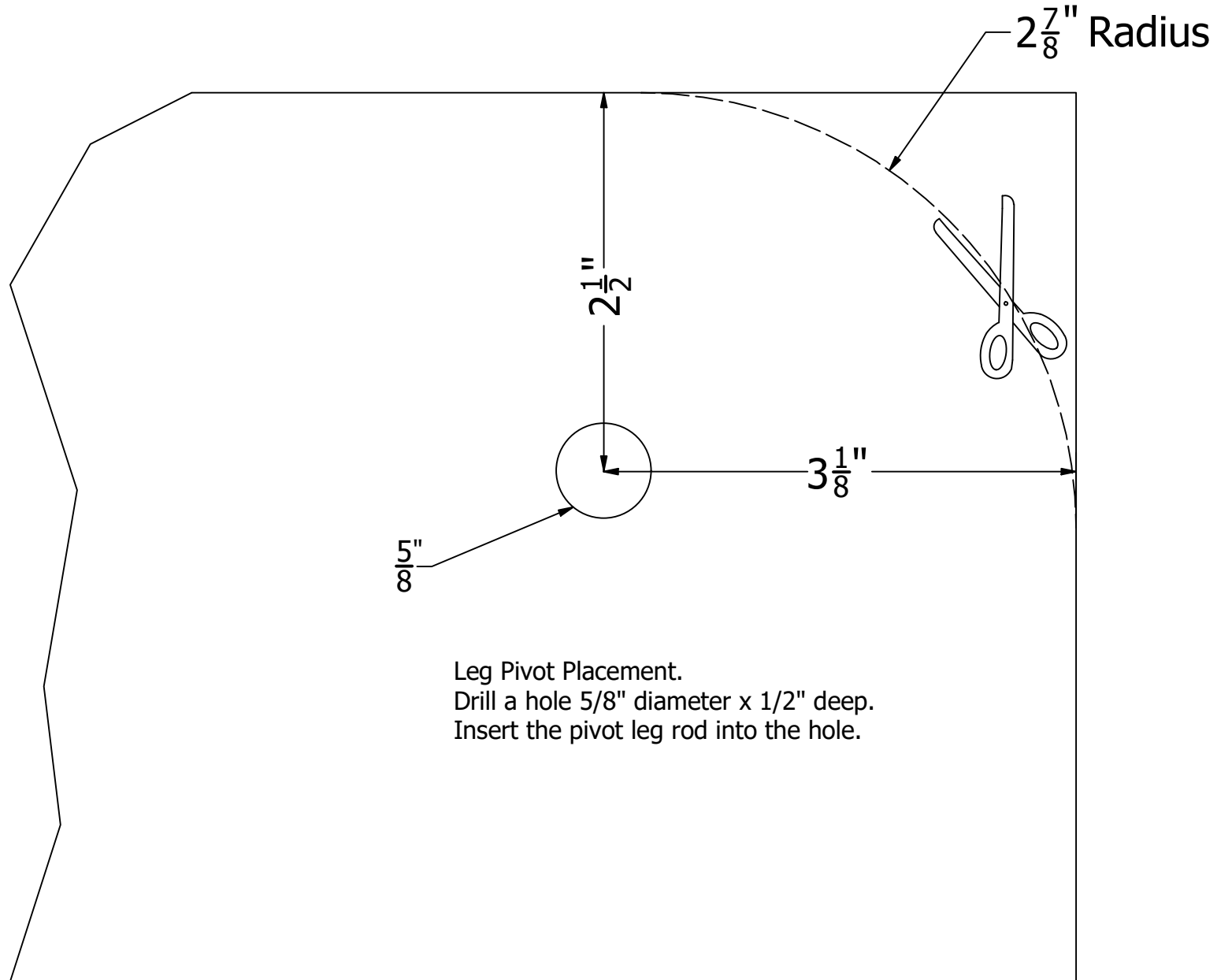

RIGHT SIDE RAIL TEMPLATE

B. RIGHT SIDE RAIL.

STEP 7: Leg placement: From the top of the side rail measure down 2-1/2" and from the front measure in 3-1/8". Drill a 5/8" diameter hole 1/2" deep.

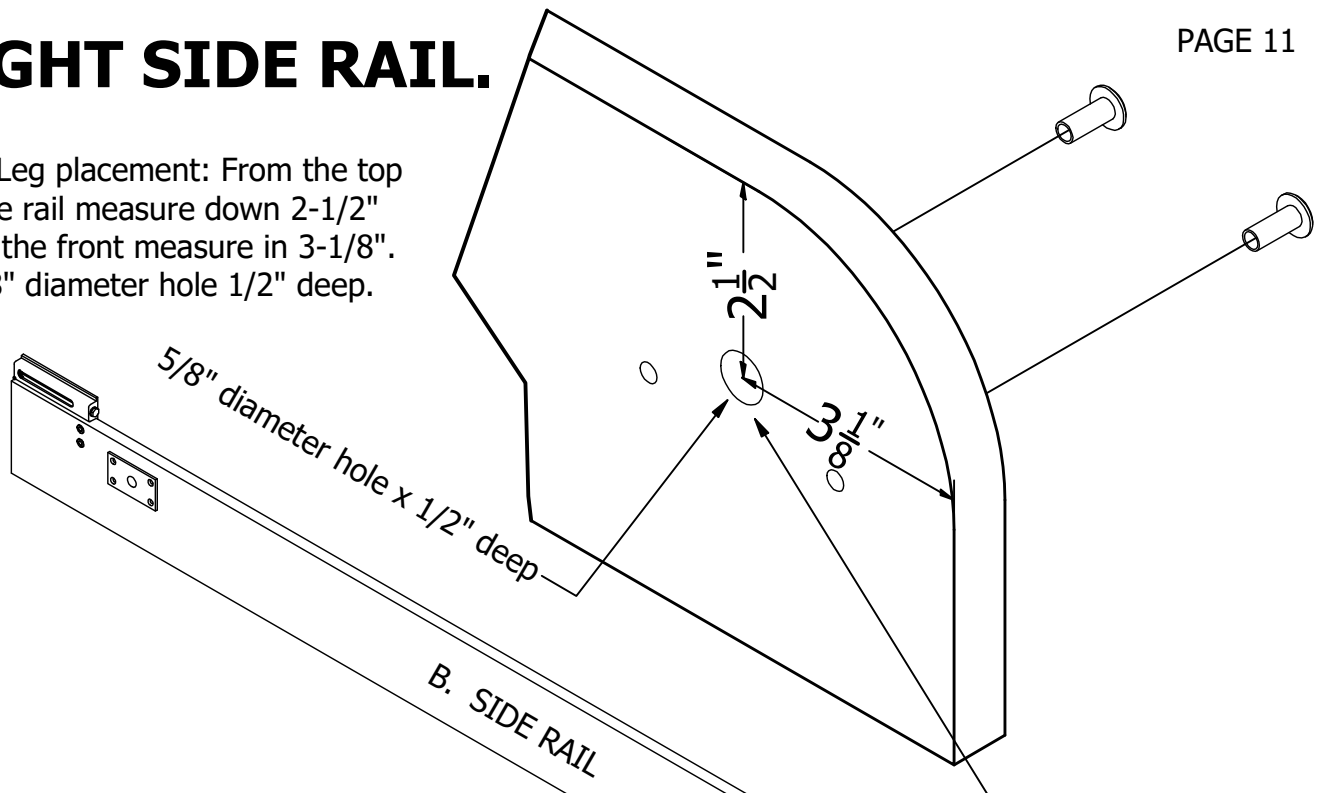

STEP 8: Place the leg pivot into the 5/8" hole. With the pivot plate parallel to the top and bottom of the side rail. Drill a 1/4" hole through the bottom 2 (two) holes in the plate through the side rails.

Note: to prevent tear out on the outside of the side rail, clamp a piece of scrap wood to rail while drilling.

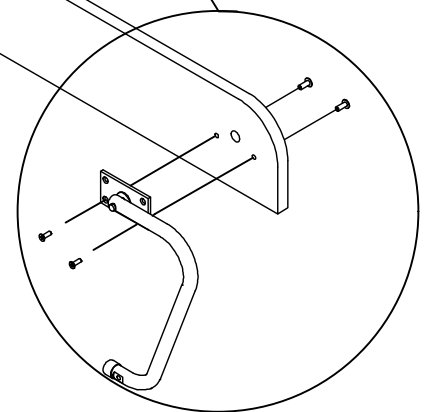

Screw 2 (two) black #10 x 3/4" screw through the top 2 holes.

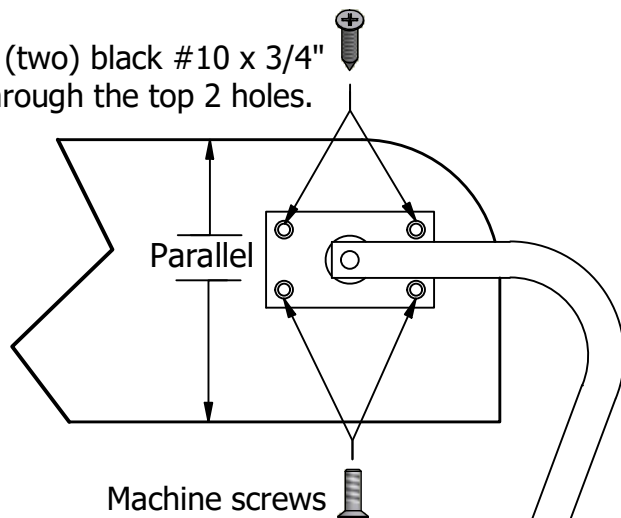

**WHEN COMPLETED
REMOVE LEG HARDWARE**

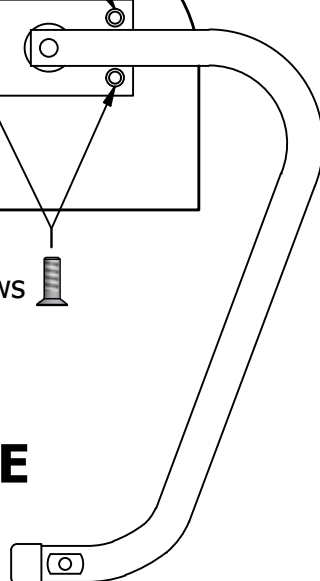

$2\frac{7}{8}$ " Radius

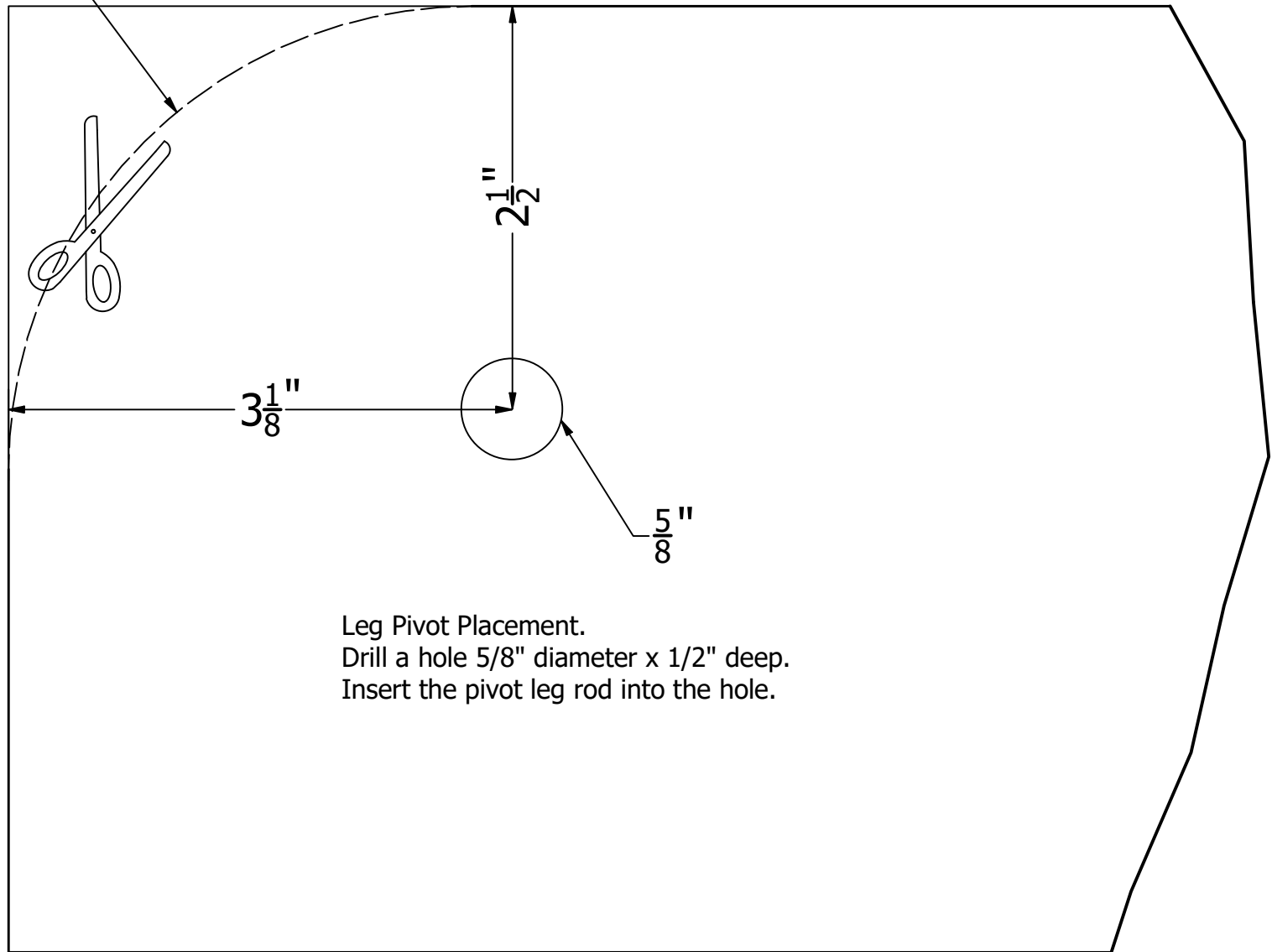

Leg Pivot Placement.
Drill a hole $\frac{5}{8}$ " diameter x $\frac{1}{2}$ " deep.
Insert the pivot leg rod into the hole.

LEFT SIDE RAIL TEMPLATE

B. LEFT SIDE RAIL.

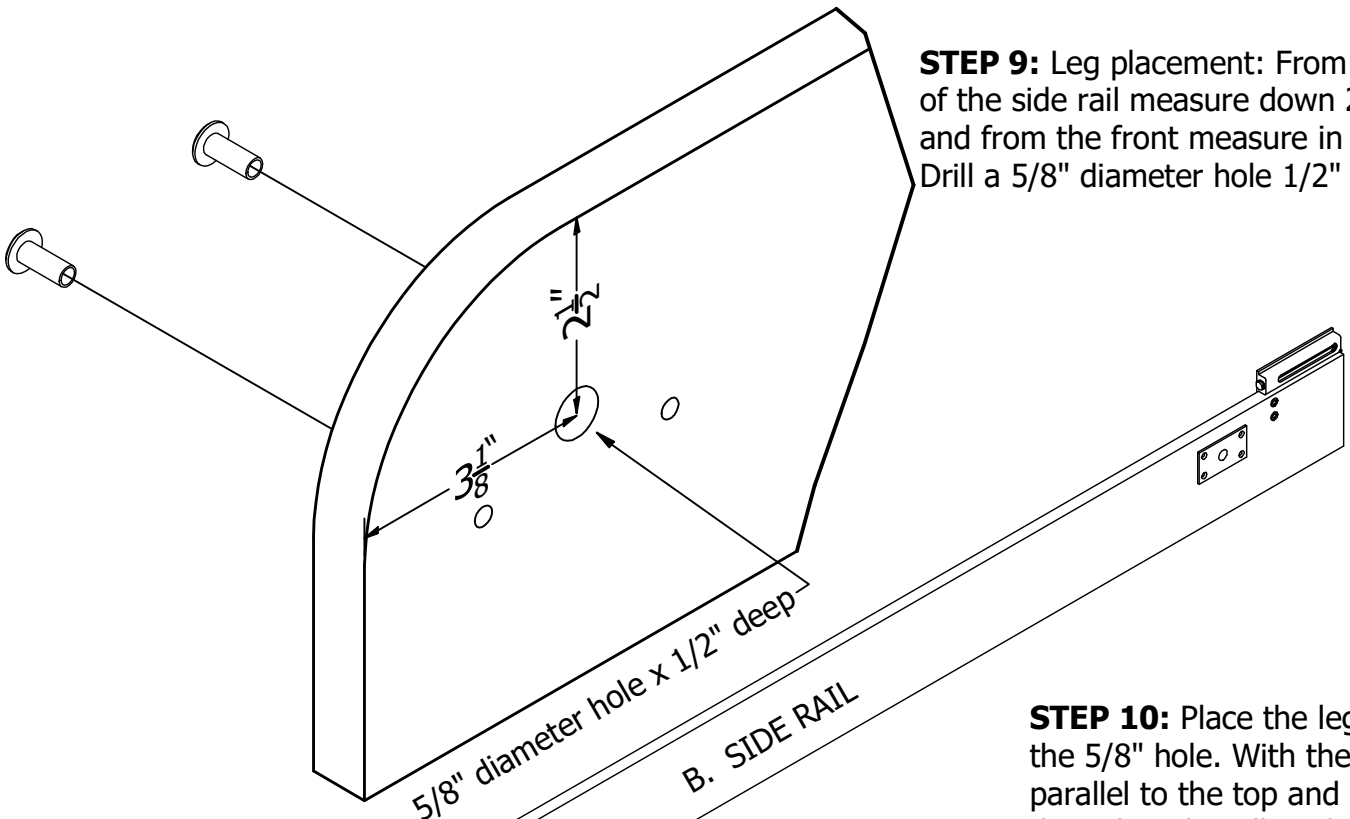

STEP 9: Leg placement: From the top of the side rail measure down 2-1/2" and from the front measure in 3-1/8". Drill a 5/8" diameter hole 1/2" deep.

STEP 10: Place the leg pivot into the 5/8" hole. With the pivot plate parallel to the top and bottom of the side rail. Drill a 1/4" hole through the bottom 2 (two) holes in the plate through the side rails.

Note: To prevent tear out on the outside of the side rail clamp a piece of scrap wood to the rail while drilling.

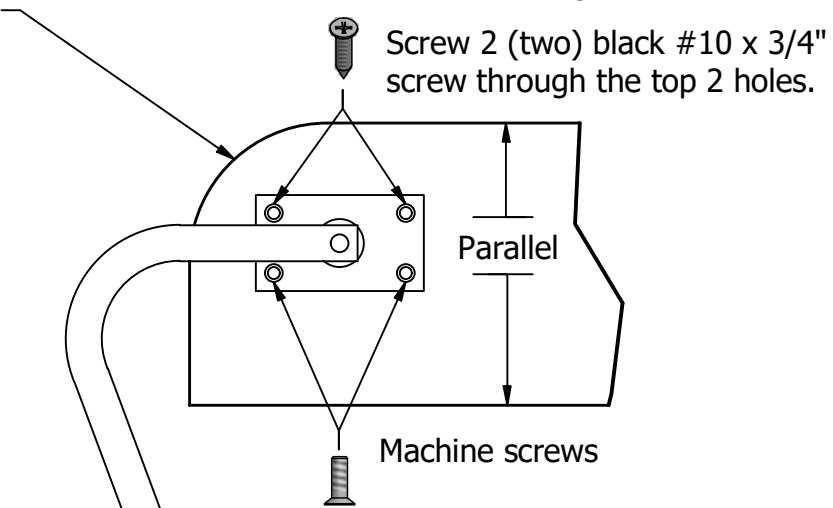
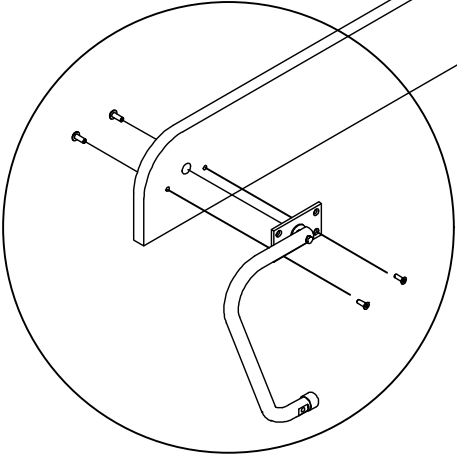

WHEN COMPLETED REMOVE LEG HARDWARE

This page pertains to the orientation and mounting positions of the lower ball stud plates and female pivots, **USE WITH PAGE 15, 16, & 17**

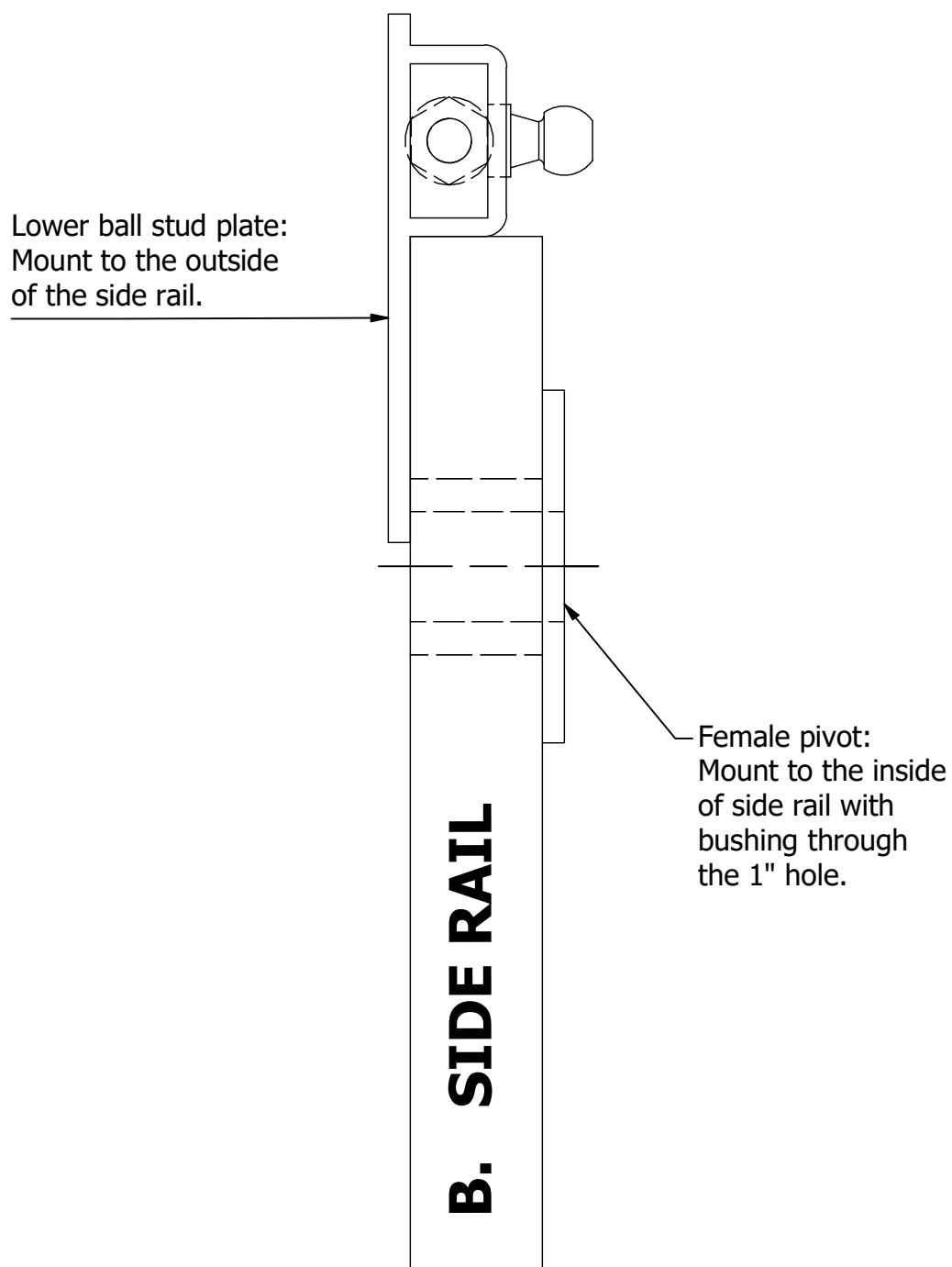

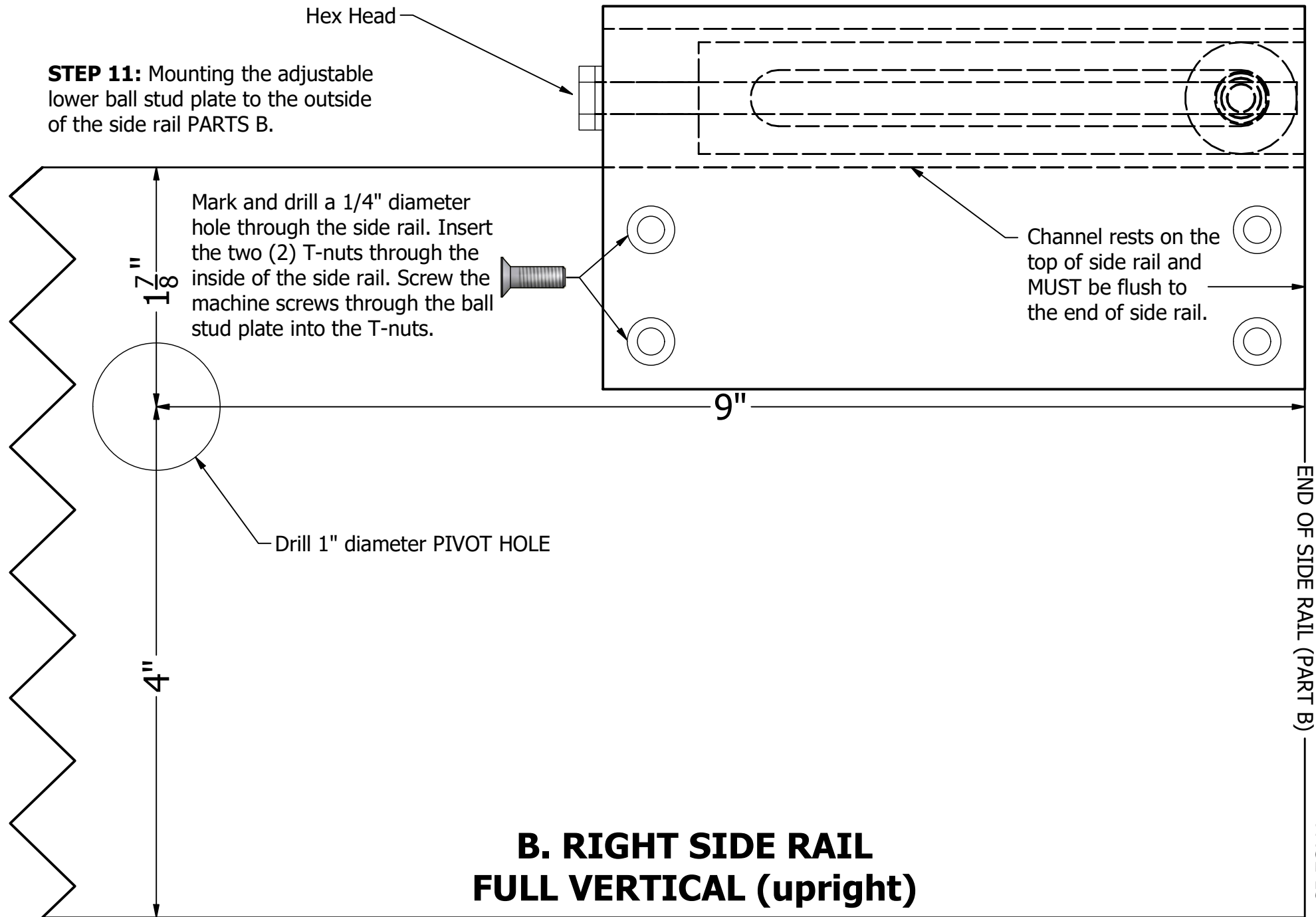

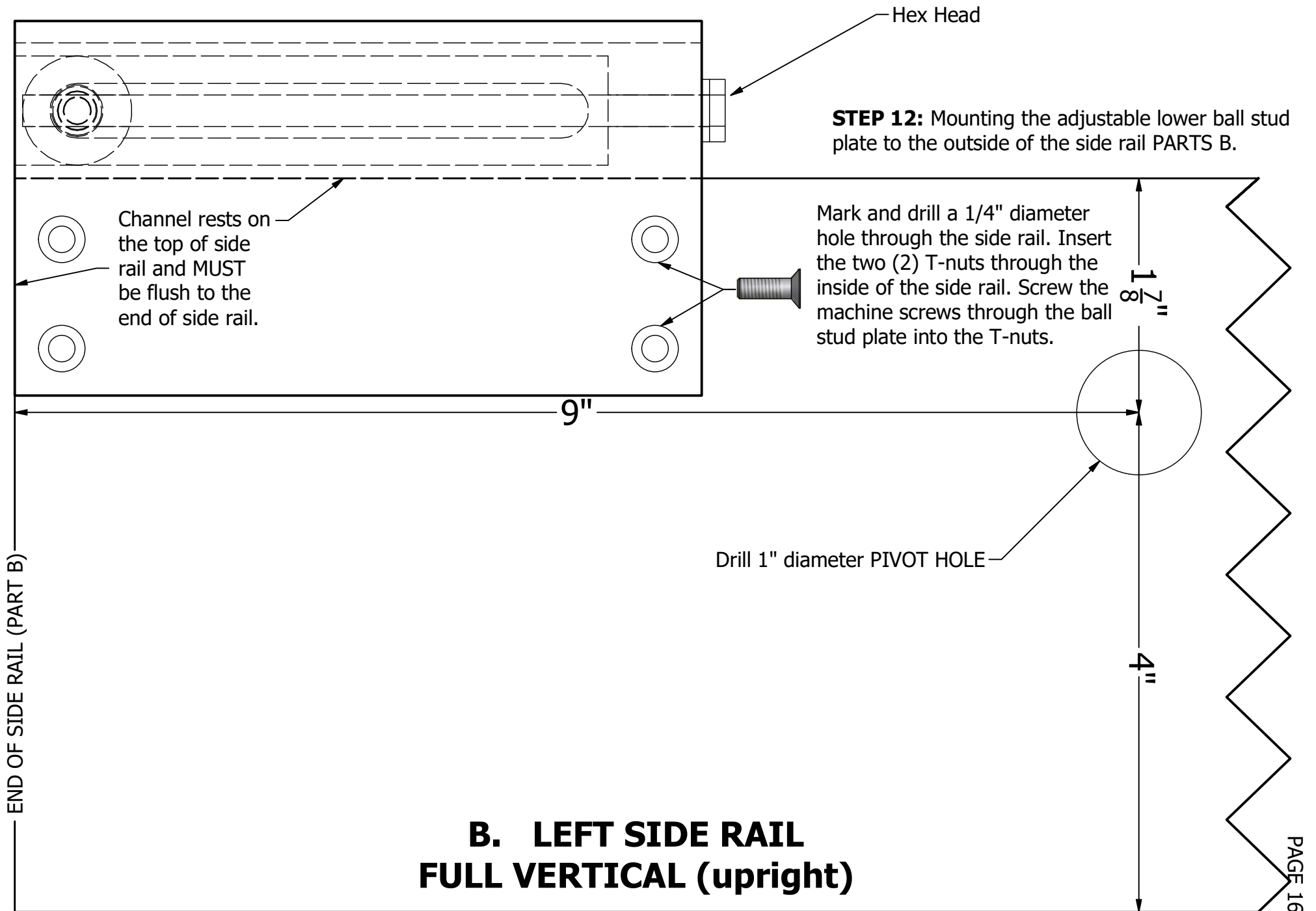

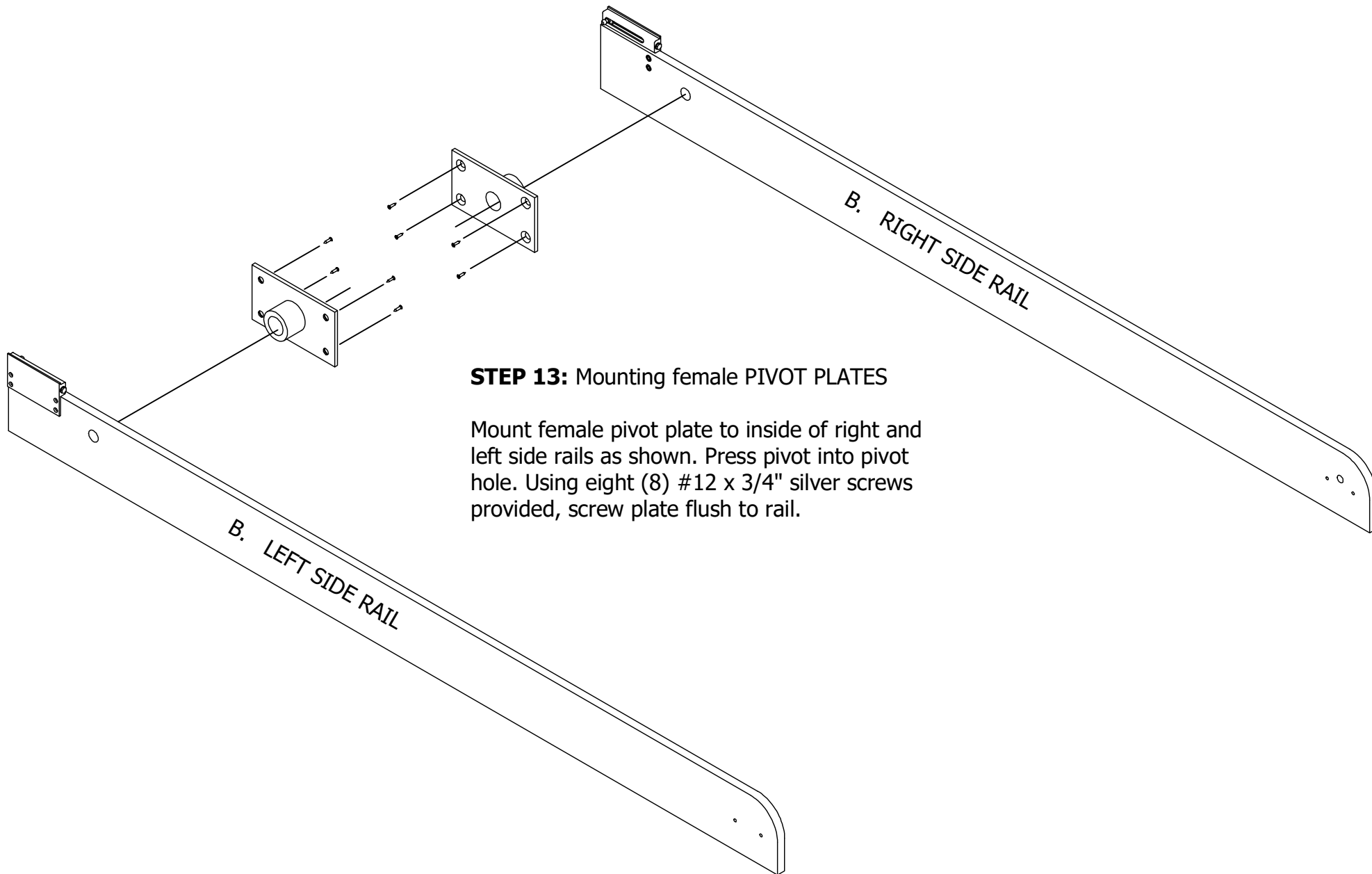

STEP 13: Mounting female PIVOT PLATES

Mount female pivot plate to inside of right and left side rails as shown. Press pivot into pivot hole. Using eight (8) #12 x 3/4" silver screws provided, screw plate flush to rail.

STEP 14: Mounting the foot rail PART C and head rail D. Drill 1/8" pilot hole 1-1/4" deep through the inner wood bed frame into the foot rail. Drive #8 x 1-1/4" screws flush. Repeat on part D Head Rail.

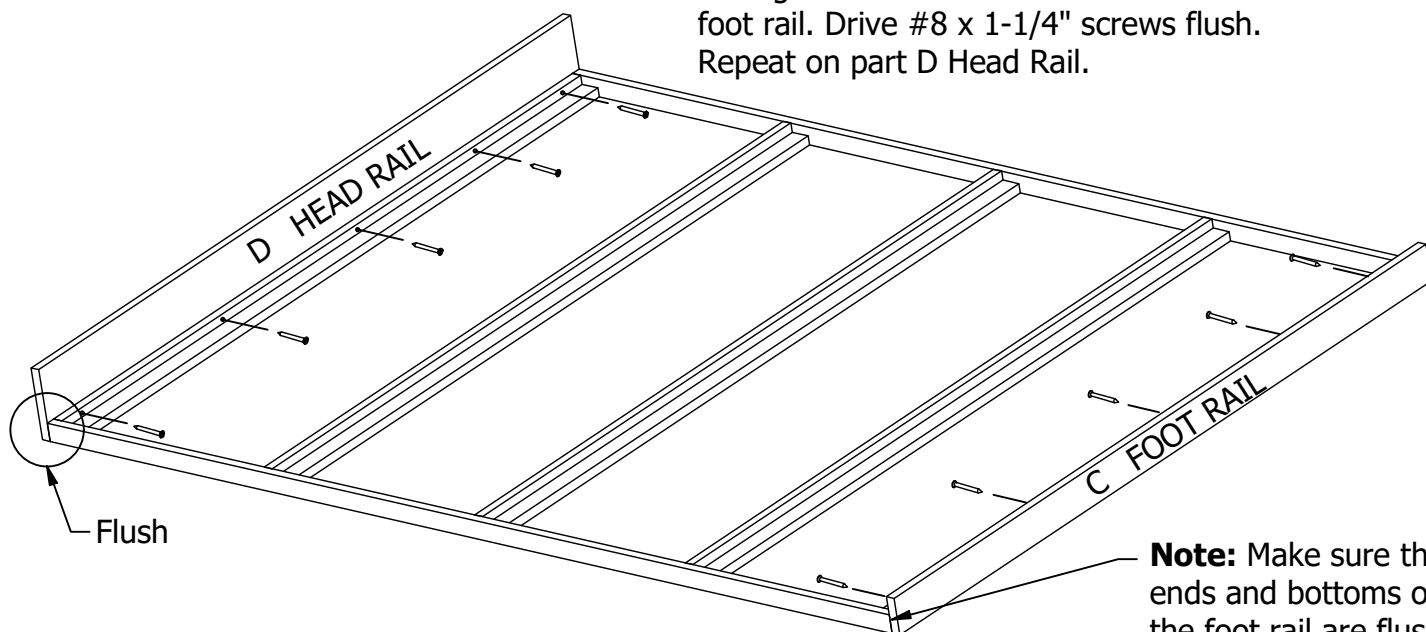

STEP 15: Mounting left and right side rail to inner wood bed frame. Using an 1/8" drill bit, drill two holes between each strut (total of 8 holes per rail) 1-1/4" deep through the frame side into the side rails. Drive #8 x 1-1/4" wood screws flush, snugging inner wood bed frame to the side rail.

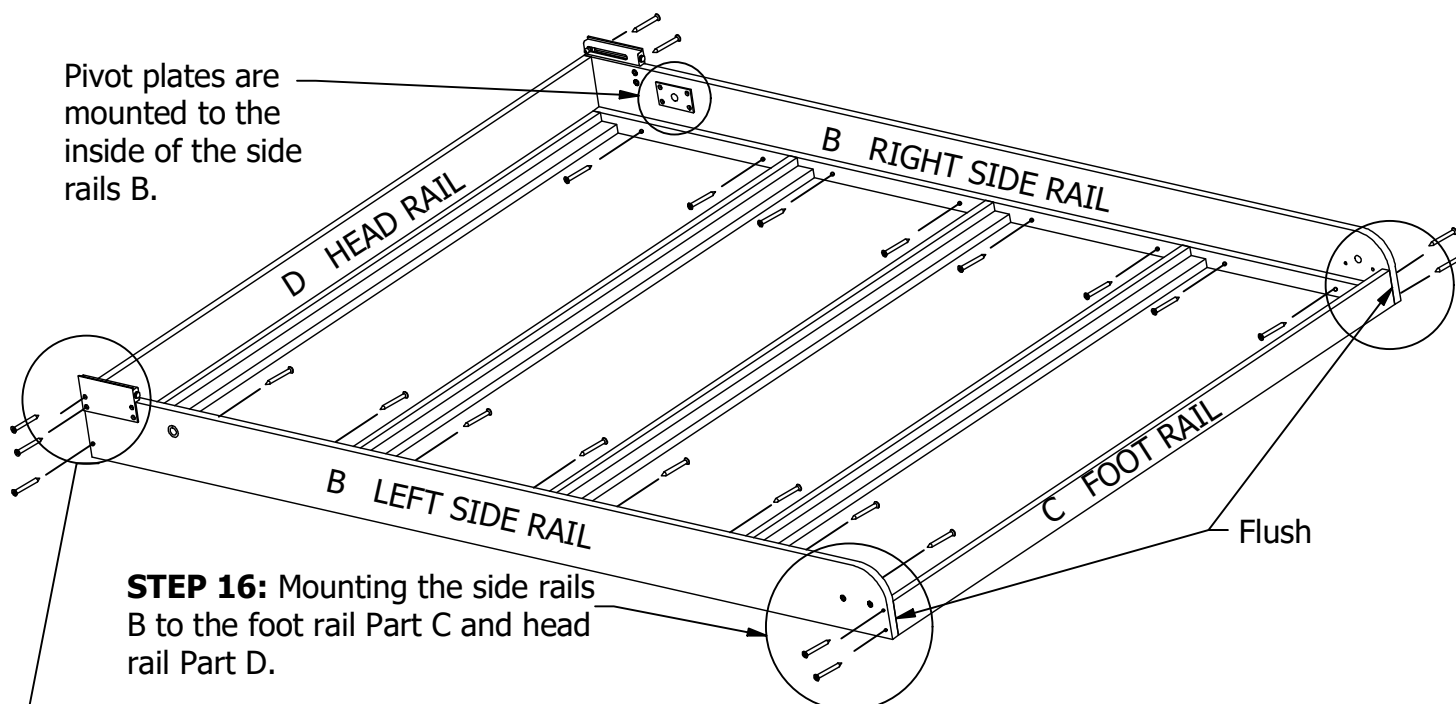

Pivot plates are mounted to the inside of the side rails B.

STEP 16: Mounting the side rails B to the foot rail Part C and head rail Part D.

Make sure side and bottom are flush. Drill 1/8" pilot hole 2" deep through the side rails into the foot rail and head rail. Drive #8 x 2" screws flush.

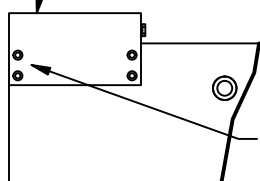

Screw two (2) #8 x 1-5/8" screws through ball stud plate into end of head rail. Repeat at other end of head rail.

STEP 17:

NOTE: For a finished look apply wood veneer or melamine edge tape to all edges marked **(F)**.

STEP 18: Turn face panels over. On back side, mark a 1/4" line the full length of the panel along finished long edge.

Pick the best side of part E Face Panel for the front of the bed.

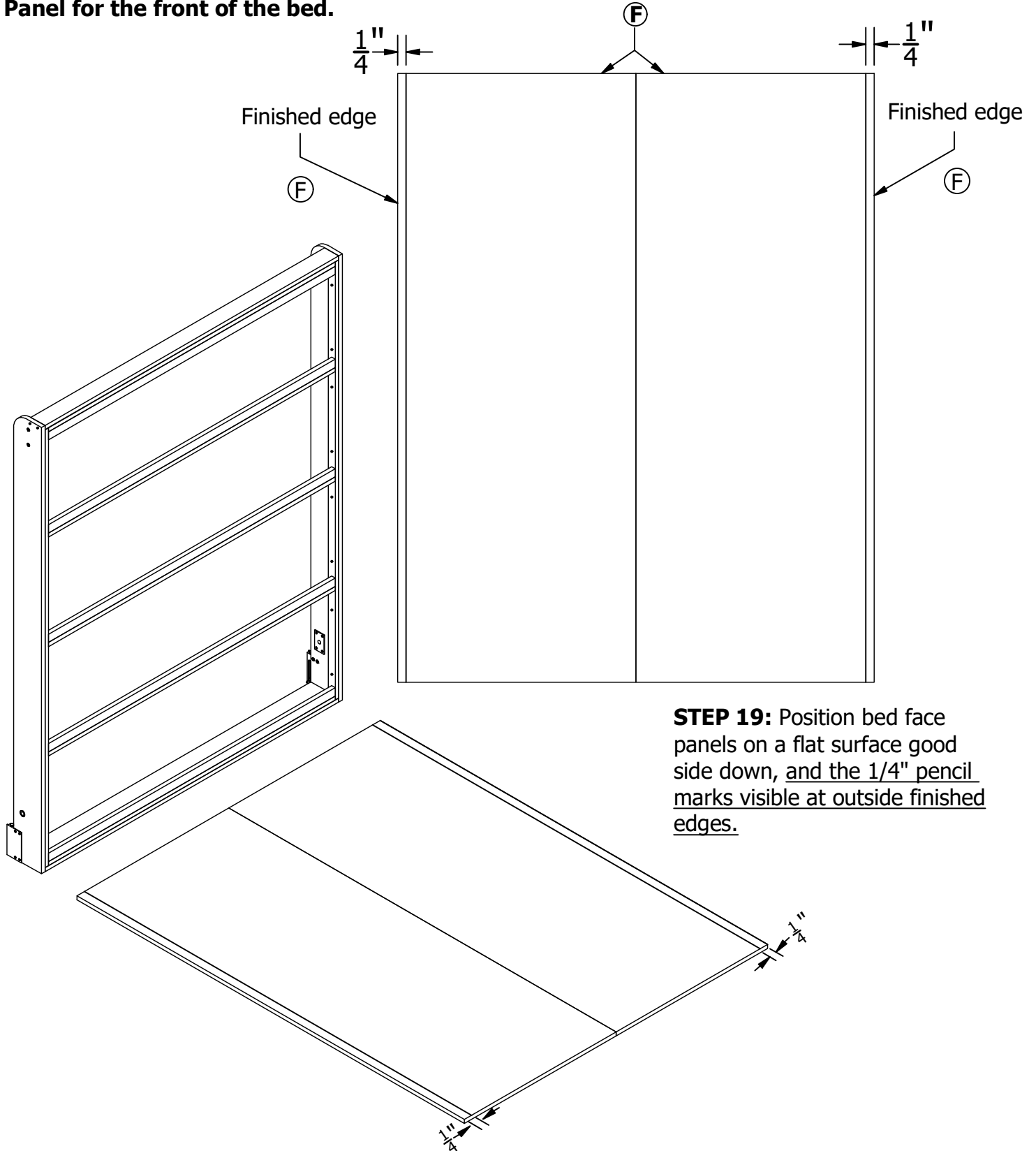

STEP 19: Position bed face panels on a flat surface good side down, and the 1/4" pencil marks visible at outside finished edges.

STEP 20: Lay bed face panel with good side DOWN, and place assembled bed frame on top of bed face panel. Check to make sure the 1/4" lines are visible on both side of the assembled bed frame.

TIP: As a guide for the application of the adhesive, mark a pencil line on the face panels PARTS E around the inner wood bed frame. After marking, remove the assembled wood bed frame and apply adhesive inside the markings.

Face panel may extend approx. 1/4" at this end.

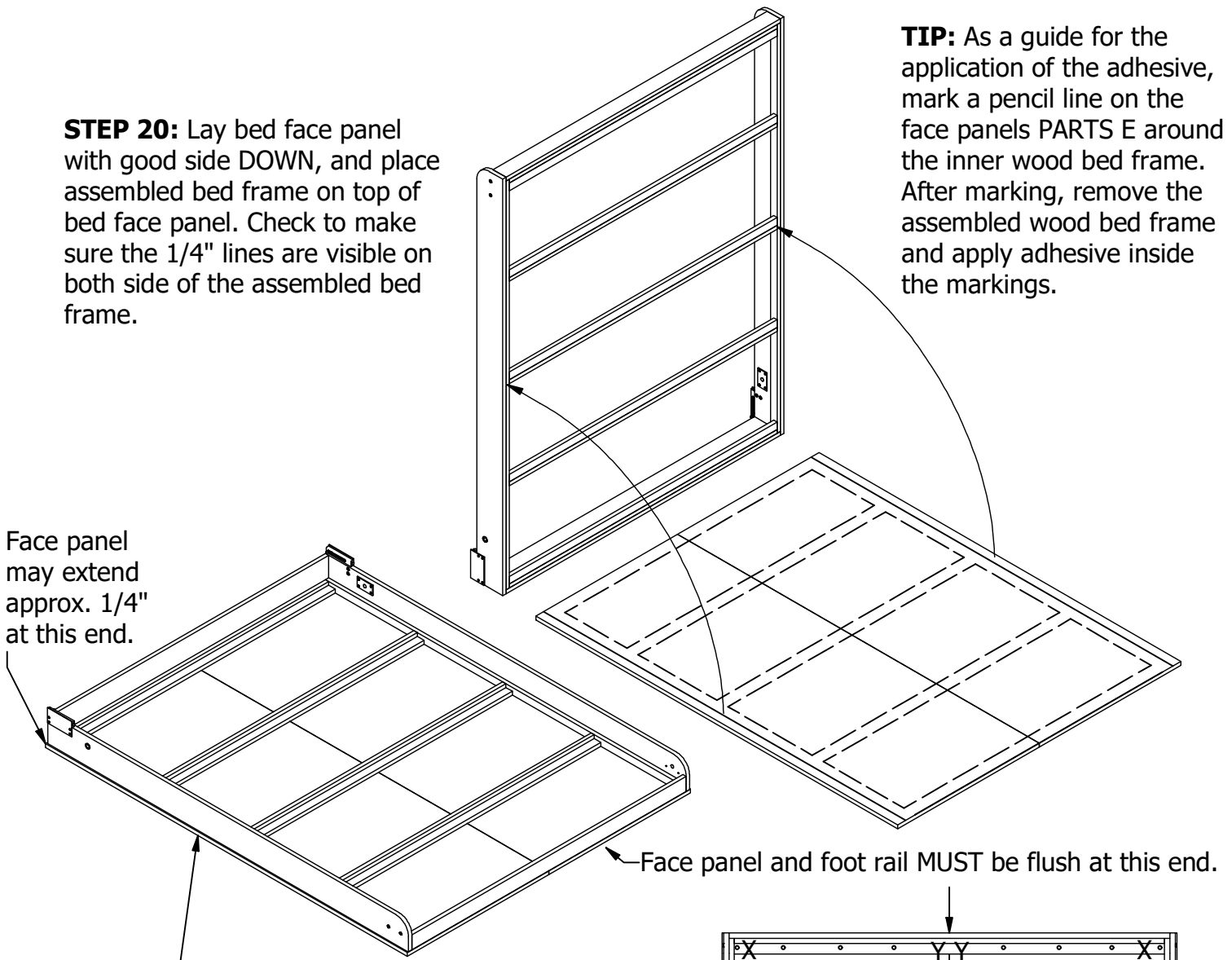

Face panel and foot rail MUST be flush at this end.

The face panel MUST extend 1/4" past edge of frame on long sides.

STEP 21: Make sure face panel and foot rail are flush and that face panel extends 1/4" past edge of wood bed frame on long sides.

Using #8 x 1-1/4" screws, screw section marked "X" first. Keeping end flush, screw section marked "Y".

Making sure there is a 1/4" face panel overhang, screw section marked "Z". If out-of-square this procedure will aid in racking into square.

Screw remaining struts to face panel 6" apart.

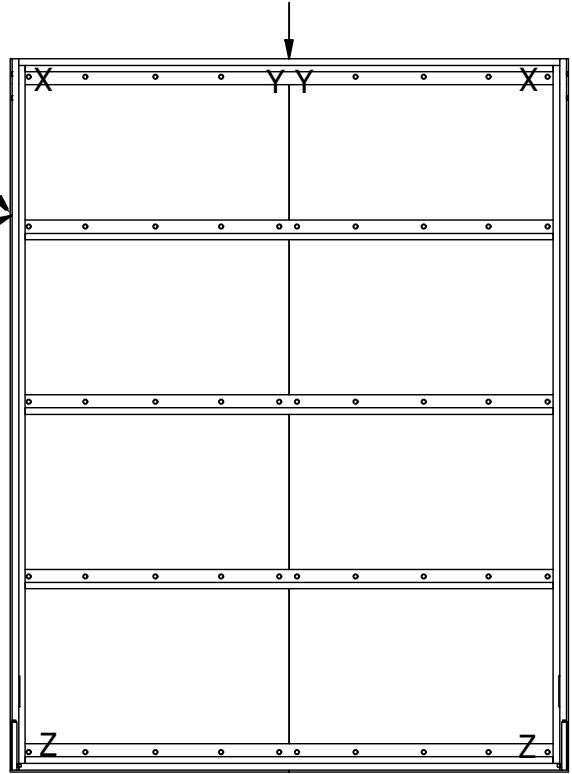

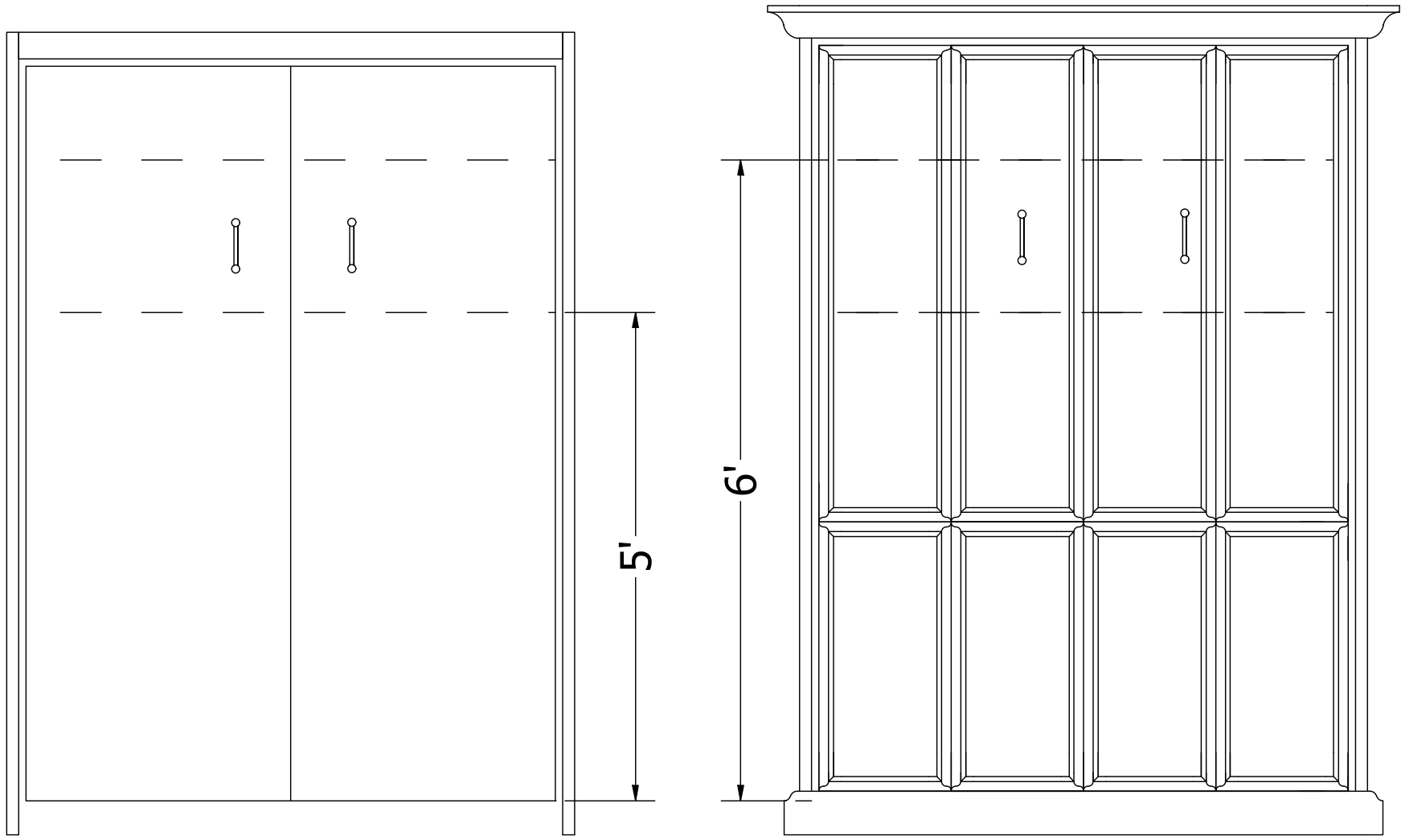

Placement of cabinet handles for optimal leverage should be between 5' and 6' on face panel PART E.

PART G: BED CABINET VERTICALS
(LEFT) For Full Vertical (Upright).

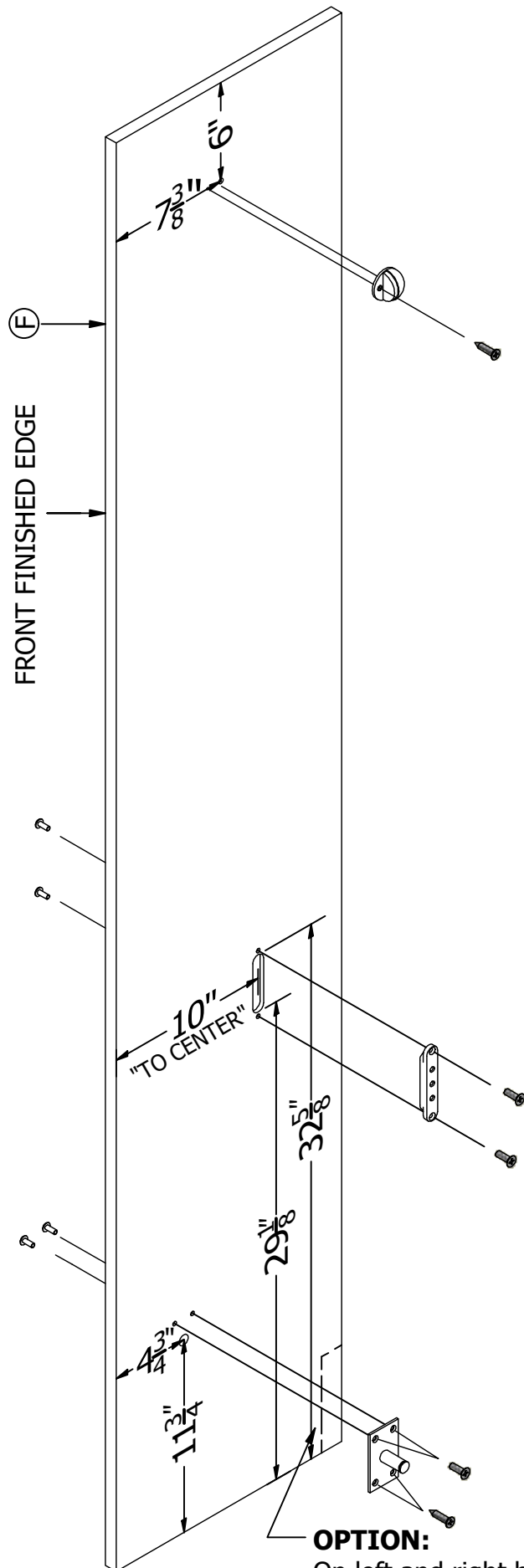

NOTE: For a finished look, apply wood veneer or melamine edge tape to all edges marked (F).

STEP 22:

BED STOP: Drill a hole $\frac{5}{16}$ " diameter x $\frac{1}{2}$ " deep. Insert the bed stop pin into hole and attach with a #10 x $\frac{3}{4}$ " black screw.

STEP 23:

ADJUSTABLE UPPER BALL STUD PLATE: Rout out $\frac{3}{4}$ " x $\frac{1}{4}$ " deep x $3\frac{1}{2}$ " long and insert the adjustable upper plate into hole. Drill $\frac{1}{4}$ " holes through the mounting locations and secure with "T" Nuts and machine screws.

STEP 24:

MALE PIVOT PLATE: Drill a hole $\frac{5}{8}$ " diameter x $\frac{1}{2}$ " deep. Insert the $\frac{1}{2}$ " end of rod into hole. Drill two (2) holes $\frac{1}{4}$ " diameter through the vertical using the upper holes in the pivot plate as a guide. Tap "T" Nuts into two (2) upper holes from outside, then screw $\frac{1}{4}$ " machine screws through pivot plate into "T" Nuts. Screw two (2) #12 x $\frac{3}{4}$ " screws through pivot plate holes into vertical.

OPTION:

On left and right bed verticals, a cut can be made to accommodate existing base molding so cabinet will fit flush against the wall.

PART G: BED CABINET VERTICALS
(RIGHT) For Full Vertical (Upright).

NOTE: For a finished look, apply wood veneer or melamine edge tape to all edges marked (F).

STEP 25:

BED STOP: Drill a hole $\frac{5}{16}$ " diameter x $\frac{1}{2}$ " deep. Insert the bed stop pin into hole and attach with a #10 x $\frac{3}{4}$ " black screw.

STEP 26:

ADJUSTABLE UPPER BALL STUD PLATE: Rout out $\frac{3}{4}$ " x $\frac{1}{4}$ " deep x $3\frac{1}{2}$ " long and insert the adjustable upper plate into hole. Drill $\frac{1}{4}$ " holes through the mounting locations and secure with "T" Nuts and machine screws.

STEP 27:

MALE PIVOT PLATE: Drill a hole $\frac{5}{8}$ " diameter x $\frac{1}{2}$ " deep. Insert the $\frac{1}{2}$ " end of rod into hole. Drill two (2) holes $\frac{1}{4}$ " diameter through the vertical using the upper holes in the pivot plate as a guide. Tap "T" Nuts into two (2) upper holes from outside, then screw $\frac{1}{4}$ " machine screws through pivot plate into "T" Nuts. Screw two (2) #12 x $\frac{3}{4}$ " screws through pivot plate holes into vertical.

OPTION:

On left and right bed verticals, a cut can be made to accommodate existing base molding so cabinet will fit flush against the wall.

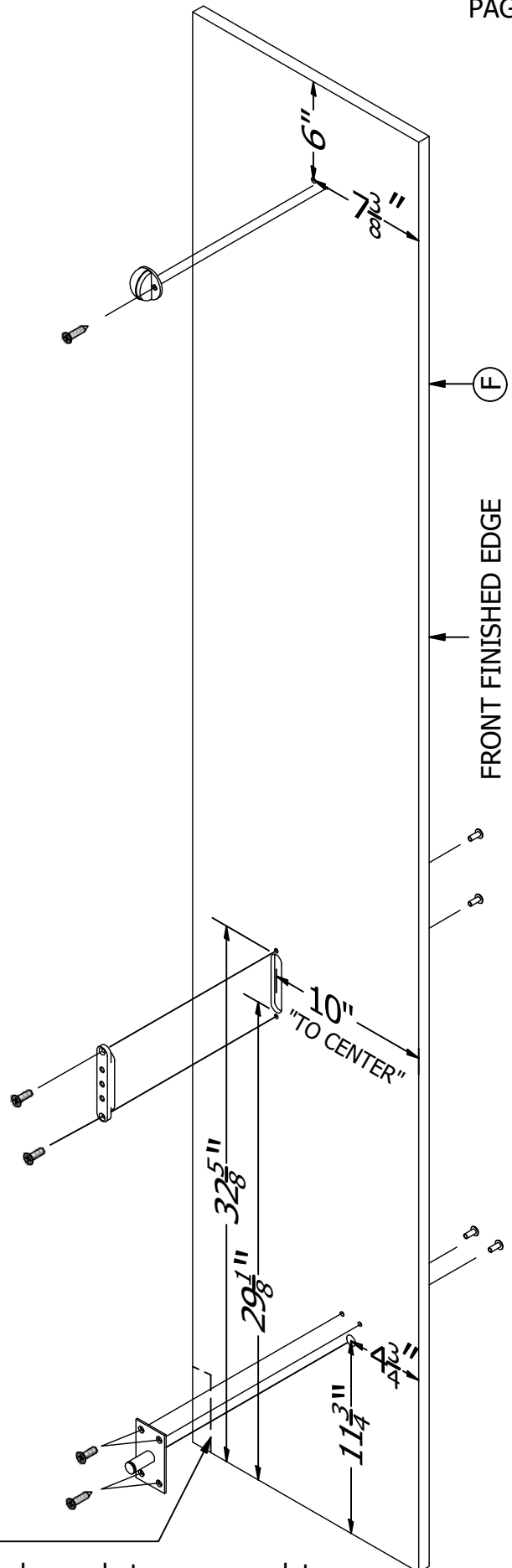

PART F: BED HEADBOARD

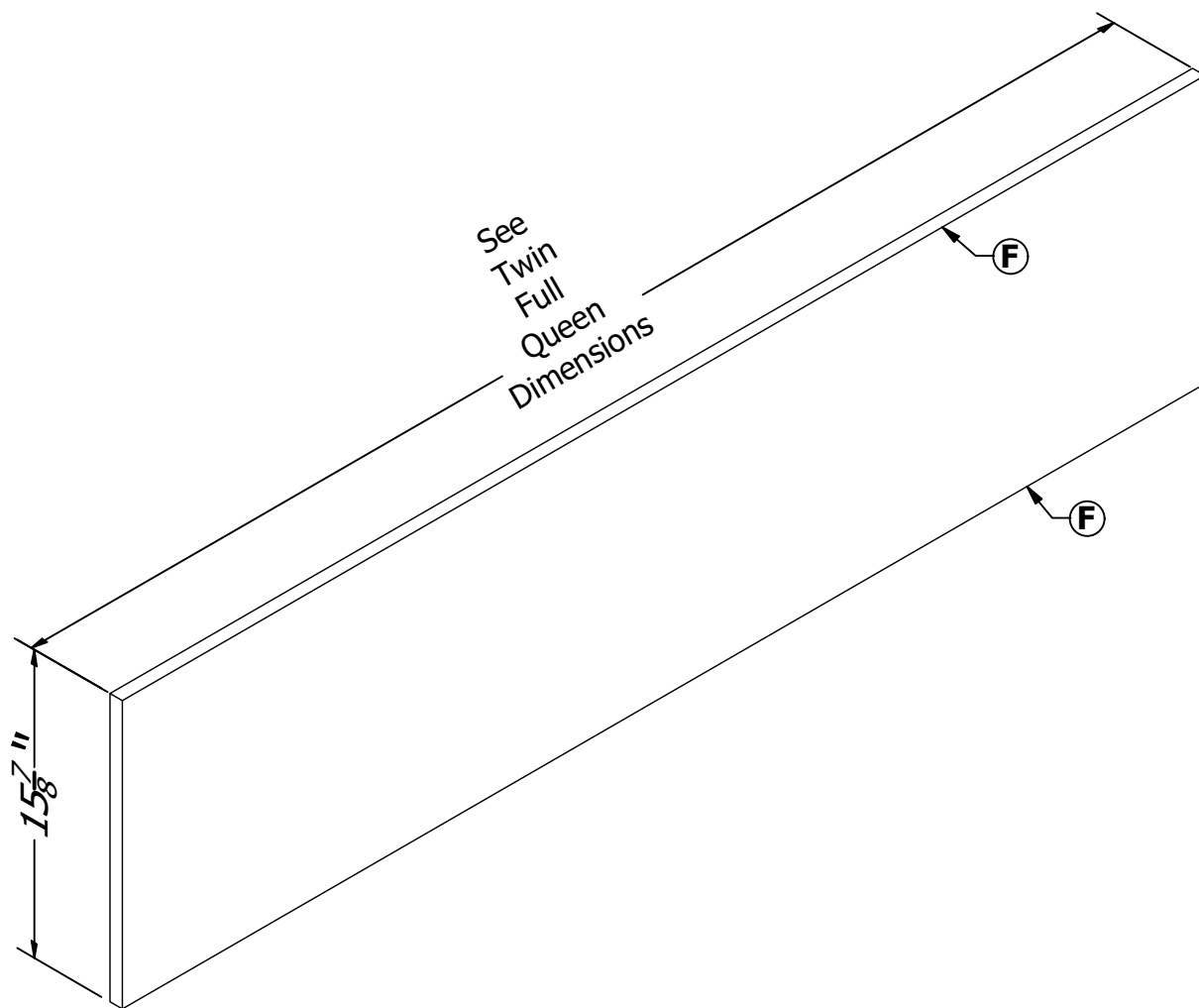

STEP 28:

NOTE: For a finished look, apply wood veneer or melamine edge tape to all edges marked **F**.

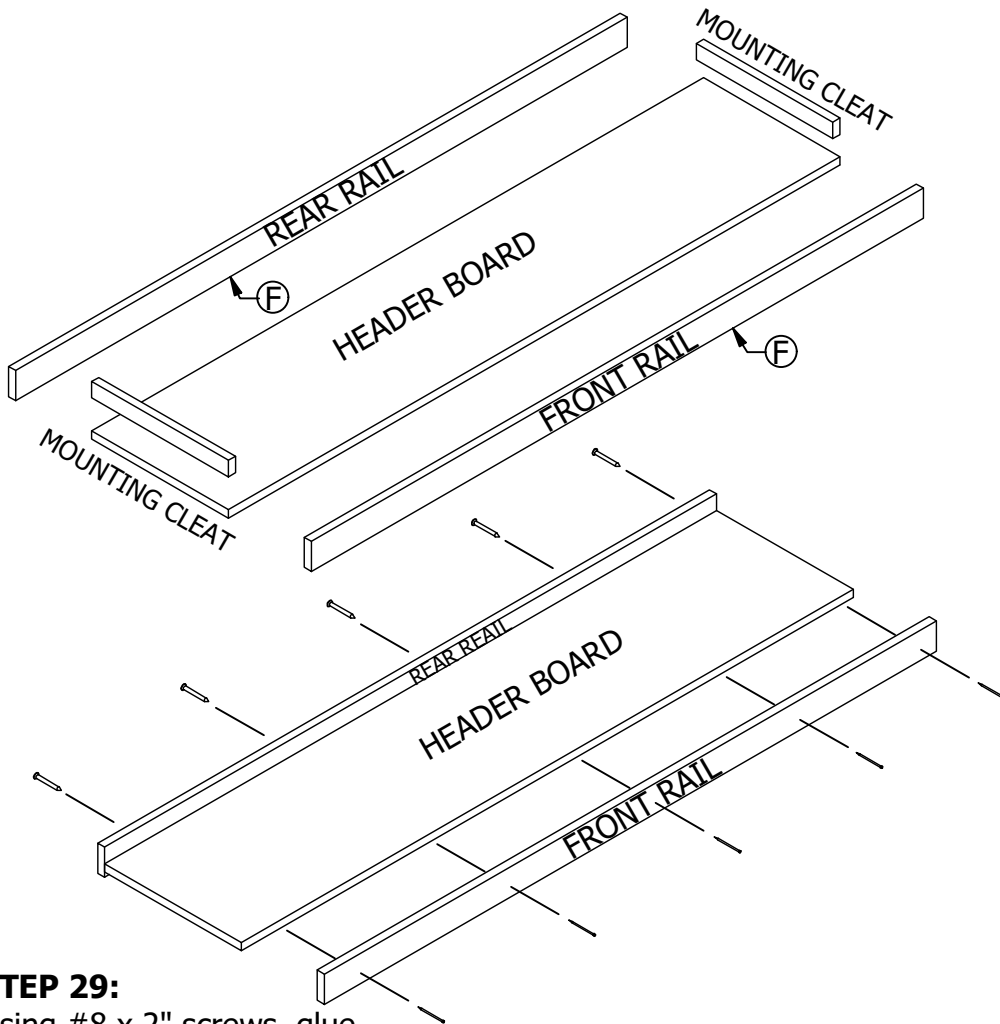

NOTE: For a finished look, apply wood veneer or melamine edge tape to all edges marked **F**.

STEP 30: Using 2" finish nails, glue and nail front rail to header board, maintaining a 1/2" lip on underside lip of header board.

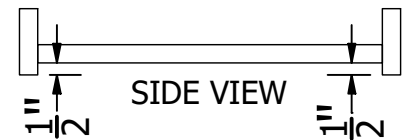

STEP 29: Using #8 x 2" screws, glue and screw rear rail to header board, maintaining a 1/2" lip on the underside of the header board.

NOTE: REAR RAIL MUST BE GLUED AND SCREWED TO HEADER BOARD.

STEP 31: Using #8 x 2" screws, glue and screw mounting cleats to header board between front and rear rails as shown.

NOTE: Be sure to drill pilot holes and counter-sink screws flush with the wood.

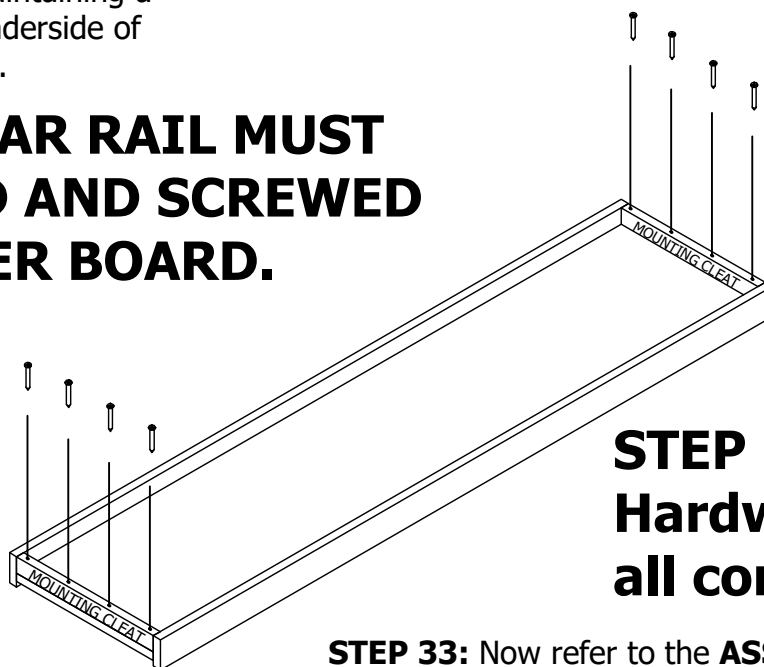

STEP 32: Remove all Hardware, sand & finish all components!

STEP 33: Now refer to the **ASSEMBLY BOOKLET** for assembling and installing your murphy bed.

ASSEMBLY INSTRUCTIONS FOR THE
VERTICAL (upright)
Create-A-Bed®
 MURPHY BED

WARNING!

This bed contains stored mechanical energy which can cause serious injury if improperly handled. Your bed MUST! MUST! be securely anchored to the wall! READ INSTRUCTIONS THOROUGHLY BEFORE ASSEMBLY AND DISASSEMBLY!

If you have ANY questions, call **TOLL FREE (877) 966-3852**

Tools needed: Power Drill, Stud Finder, Tape Measure, Phillips-Head Screwdriver, Flat-Head Screwdriver, #4 Allen Wrench, 7/16" Socket, 1/2" Wrench, Clamps and Drill bits appropriate for your mounting surface (see step 16 on page 10).

STEP 1:

Replace all hardware on bed components EXCEPT FOR THE BED STOPS. Familiarize yourself with all COMPONENTS in Figure 1. Position PARTS in front of desired cabinet location.

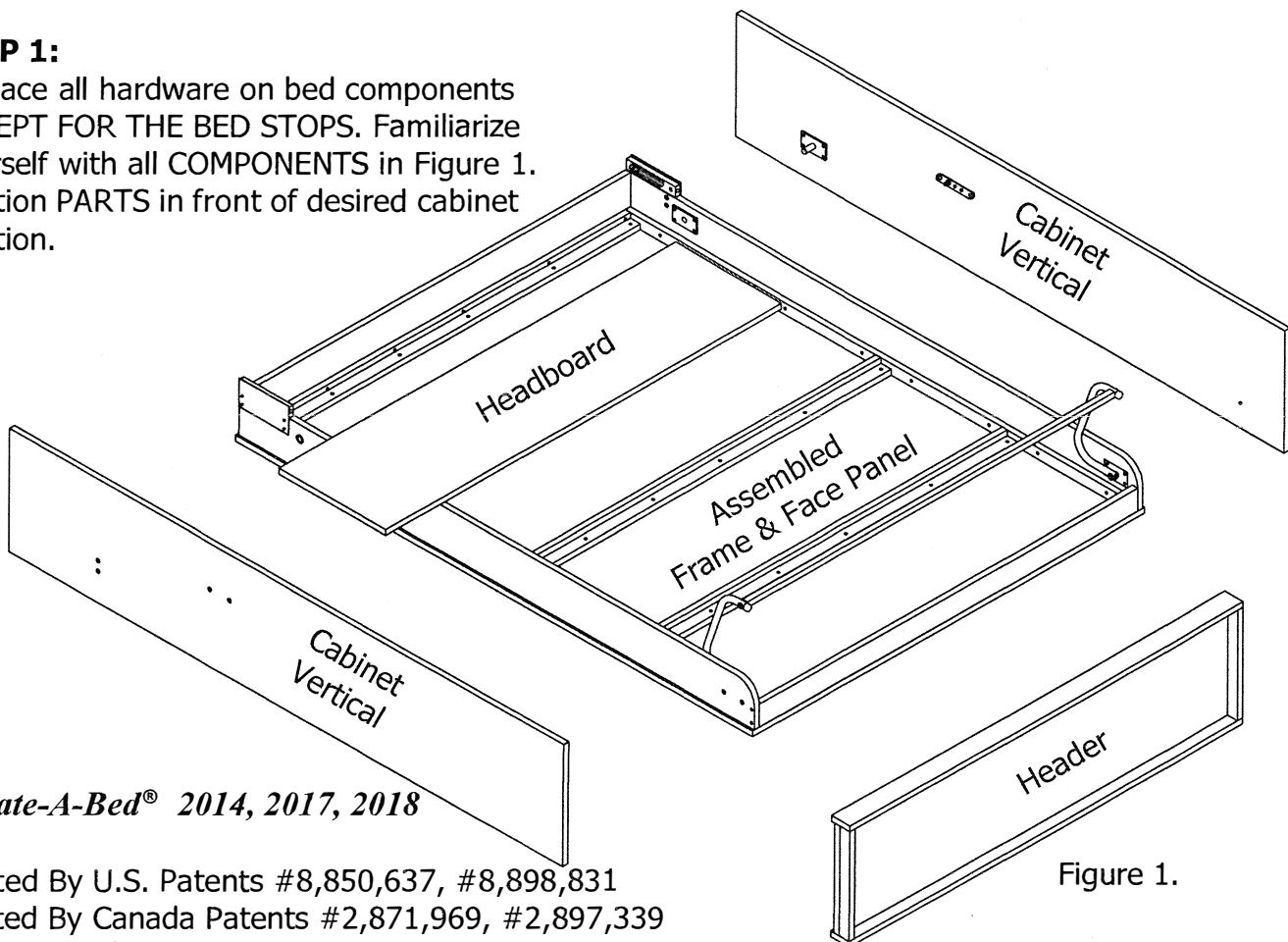
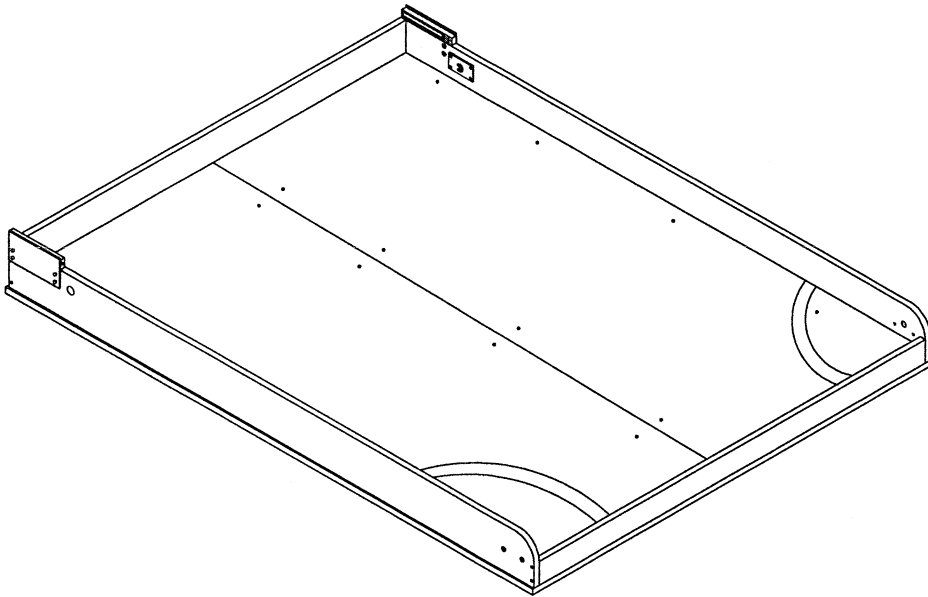

Figure 1.

© Create-A-Bed® 2014, 2017, 2018

Protected By U.S. Patents #8,850,637, #8,898,831
 Protected By Canada Patents #2,871,969, #2,897,339
 Protected By China Patent #ZL 201380032662.0
 Protected By Mexico Patent #351674



STEP 2:

Lay 1/4 inch plywood mattress support (PART J) on inner bed frame and attach with screws. **DO NOT GLUE.** Screw ends of both mattress retaining straps thru 1/4 inch plywood (PART J) into inner wood bed frame, 16 (sixteen) inches from front corners of face panel as shown.

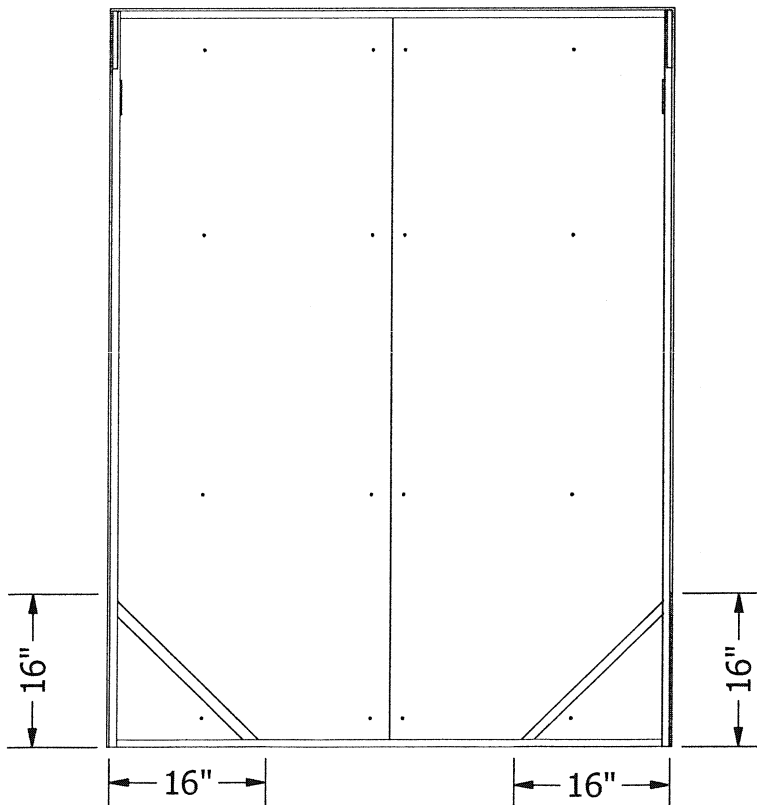

Initial Settings for Adjustable Lower Ball Stud Plate Using 3/4" Material

These settings are **SPECIFIC** to the size and style of bed you ordered.
See Page 11 for instructions on how to adjust your bed to balance correctly.

VERTICAL (upright) **PLYWOOD**

Queen	SET ON #5
Full	SET ON #4
Twin	SET ON #3

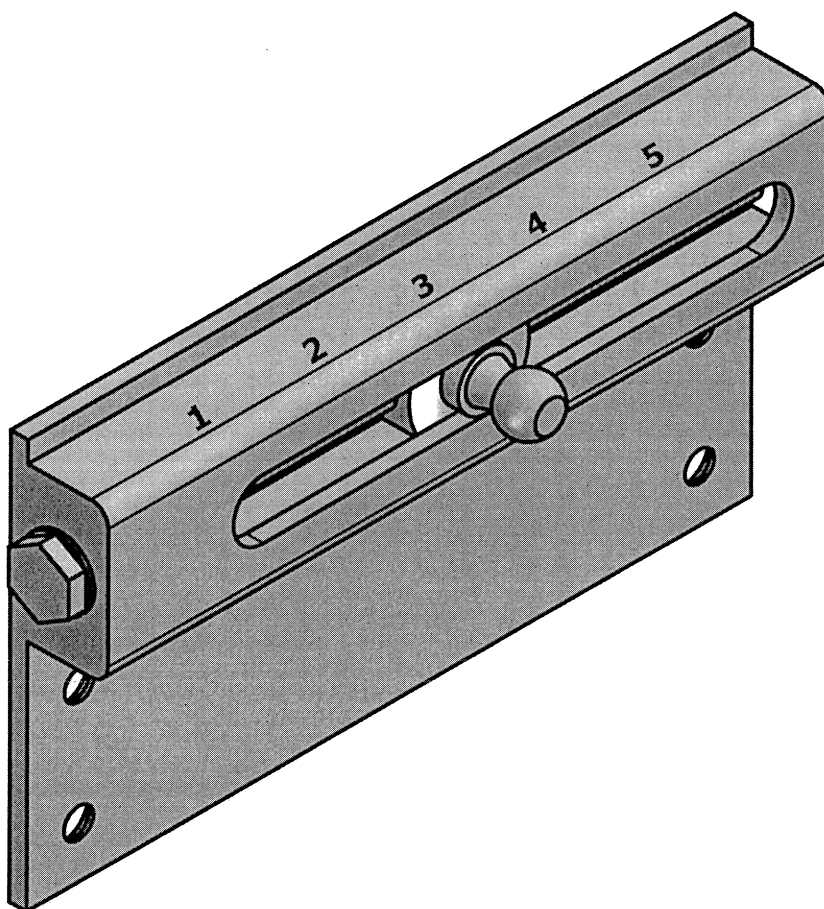

Settings for Adjustable Upper Ball Stud Plate Using 3/4" Material

These settings are **SPECIFIC** to the size and style of bed you ordered.

VERTICAL (upright) **PLYWOOD**

Queen	USE #3
Full	USE #2
Twin	USE #1

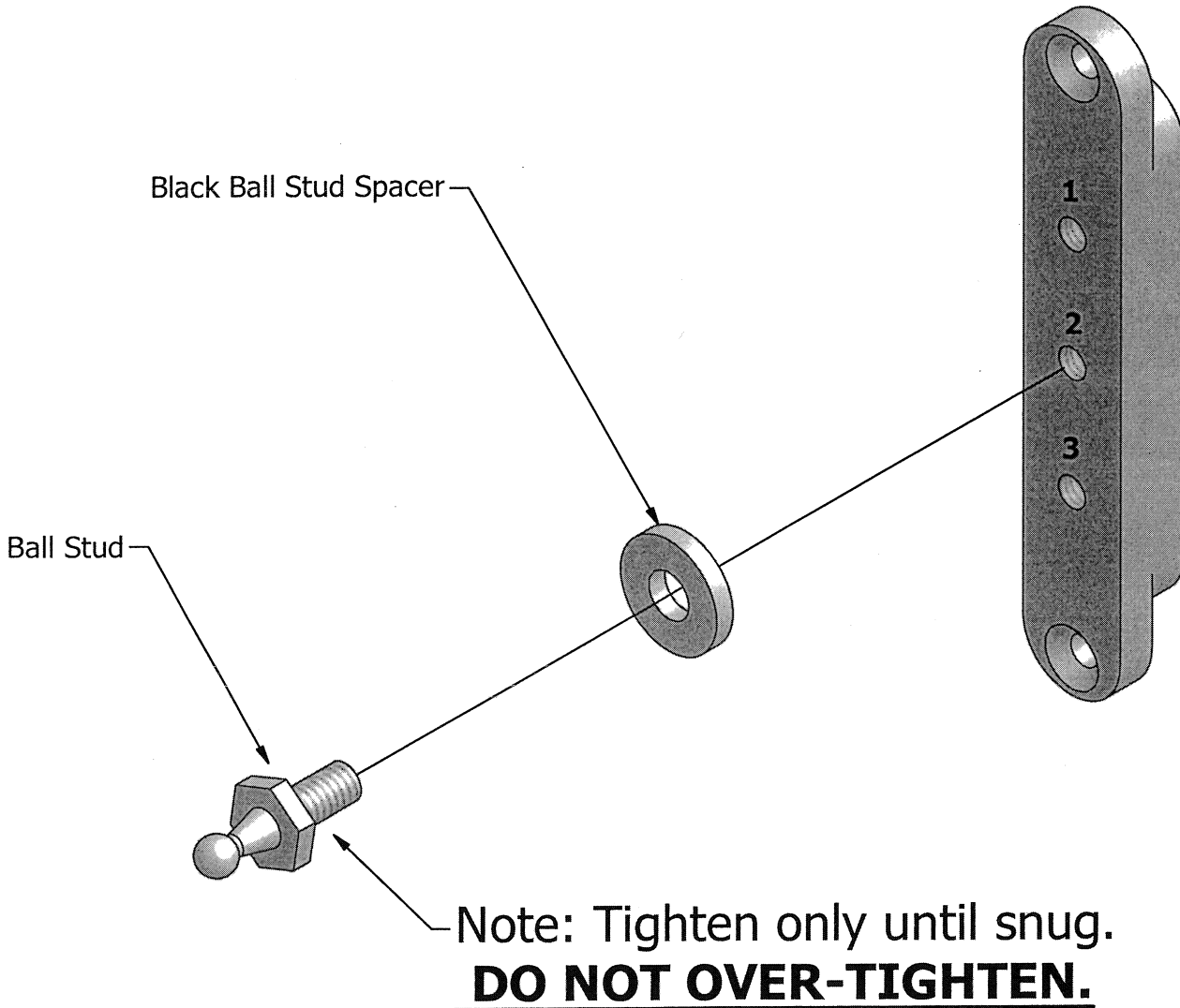

STEP 3:

Lay assembled FRAME and FACE PANEL face-down on a padded surface - i.e. - a blanket or rug.

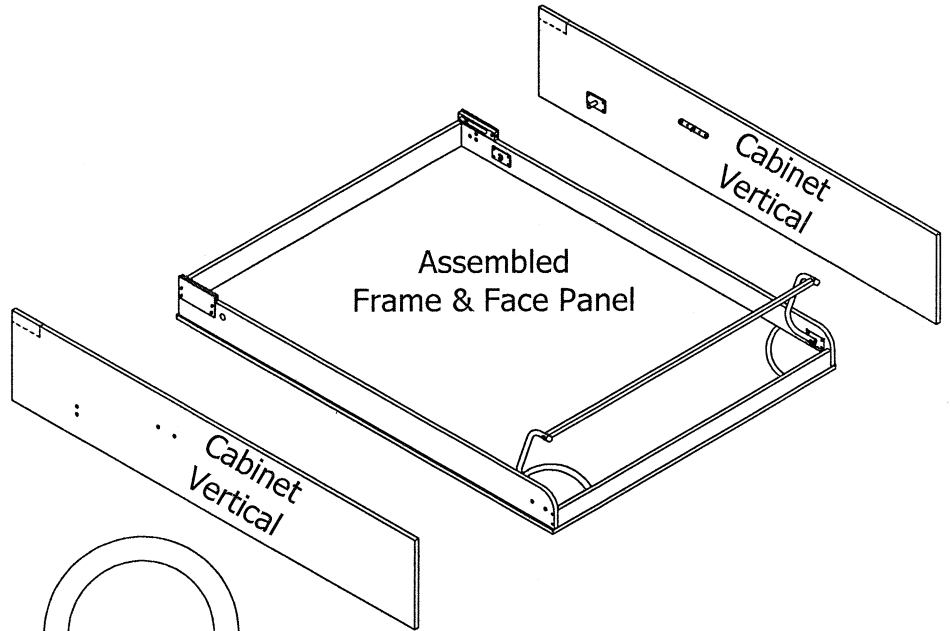

STEP 4:

Lay CABINET VERTICALS on finished (front) edge as shown.

STEP 5:

Slide PLASTIC SPACERS onto PIVOT BARS.

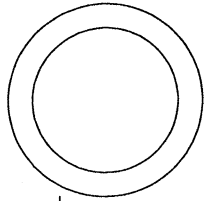

STEP 6:

Slide PIVOT BARS into PIVOT HOLES in bed frame until no gap remains between bed frame and verticals.

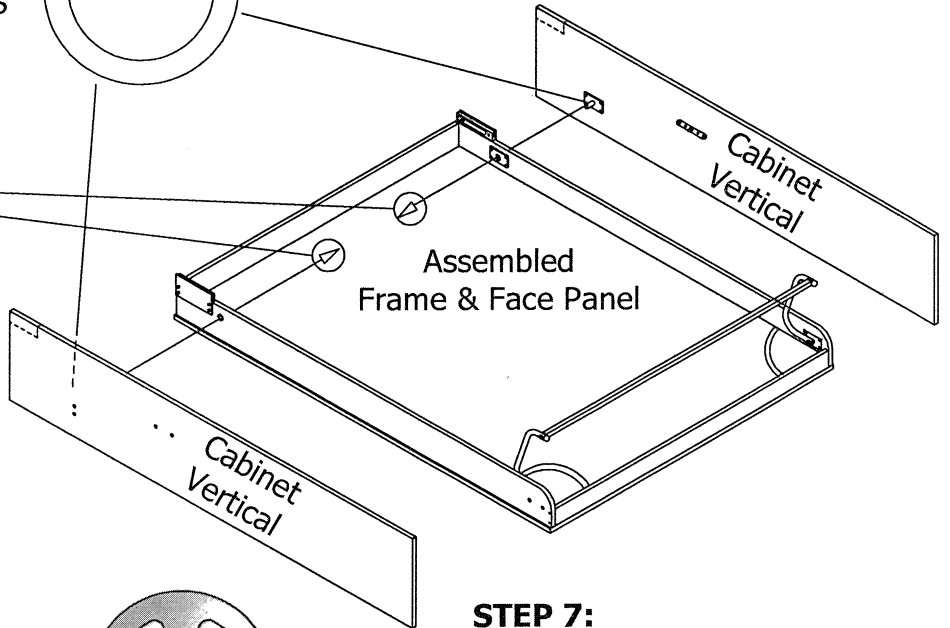

STEP 7:

Snap the E-Clips into the grooves on both pivot bars.

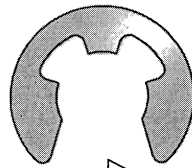

STEP 8:

Measure up and mark a reference point 15 inches from the end of the vertical. Measure up 18 inches and 28 inches, mark and drill two pilot holes. Screw the headboard into place as shown using #8 x 2 inch screws.

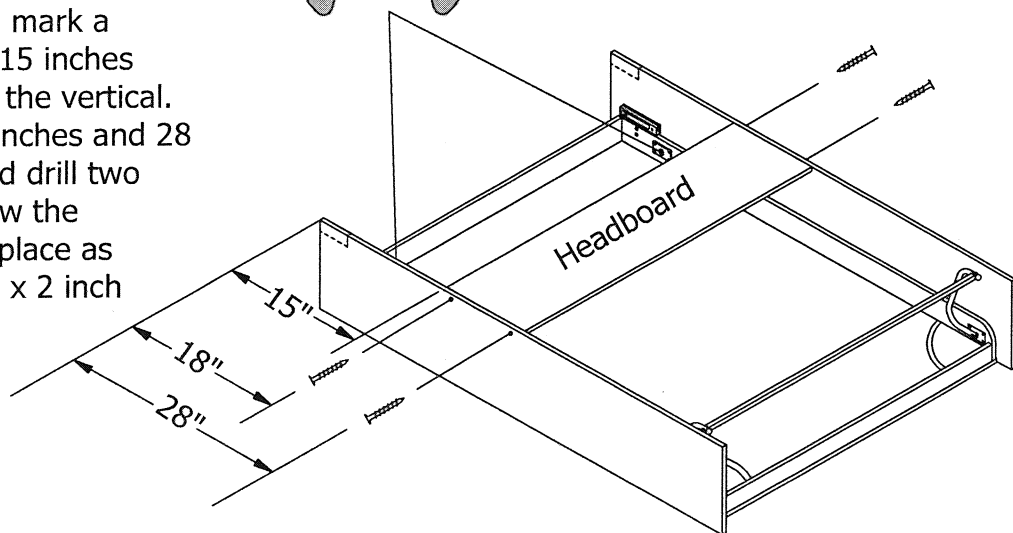

STEP 9:

With the BED FACE PANEL remaining face-down on padding, **and the legs in the closed position**, slowly and carefully rotate the CABINET VERTICALS and the HEADBOARD assembly into its upright position.

NOTE: To prevent damage to the legs, be sure they are in the closed position when rotating the bed into the upright position.

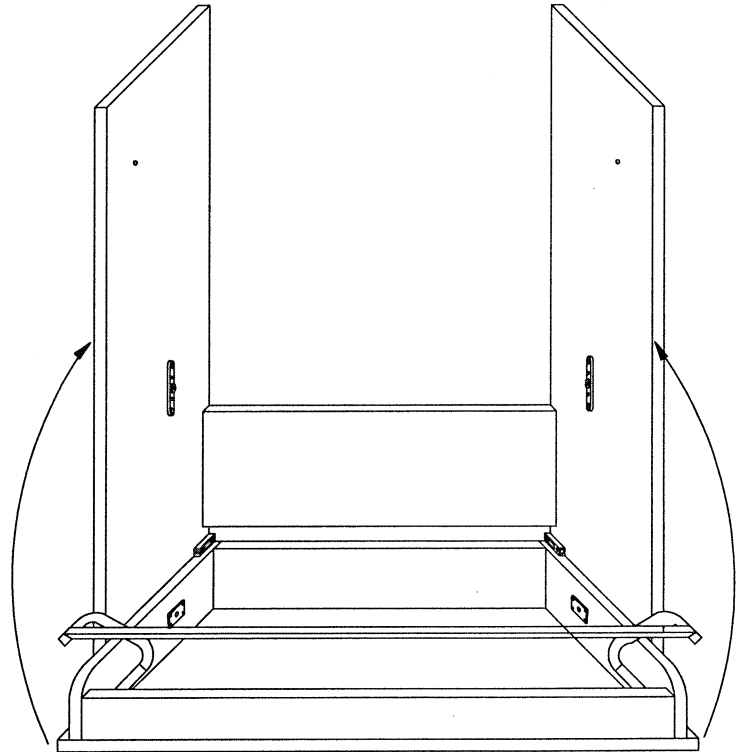
**STEP 10:**

Place the header between the bed verticals, making sure the nailed rail is in front, and the screwed rail is in the rear. Be sure top front and top rear of the header are FLUSH with the top front and top rear of the bed verticals. Using #8 x 1-1/4 inch screws, drill and screw through mounting cleats into the bed verticals, four (4) on each side.

NOTE: Clamps will be very helpful to hold the bed header between the bed verticals.

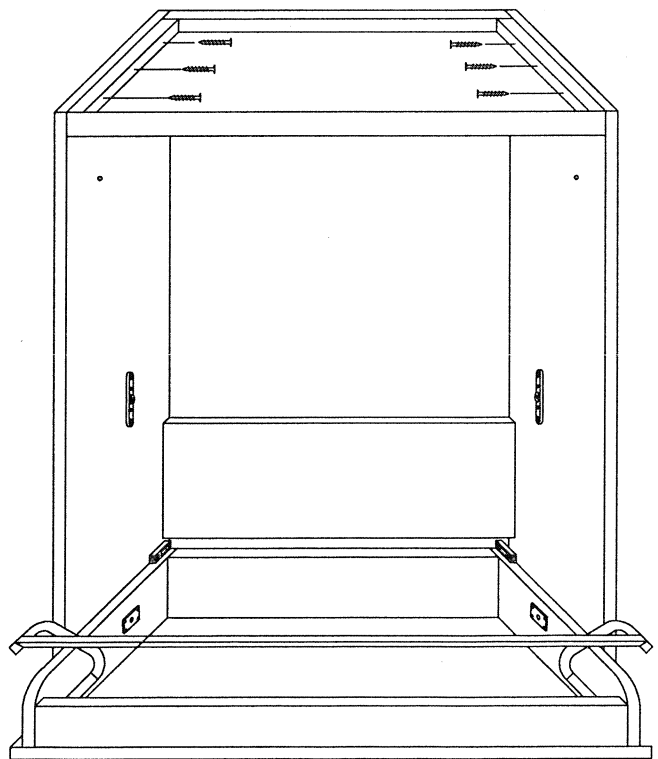

STEP 11:

Place bed cabinet 2 to 3 feet away from the wall, allowing enough room to comfortably work behind the bed cabinet.

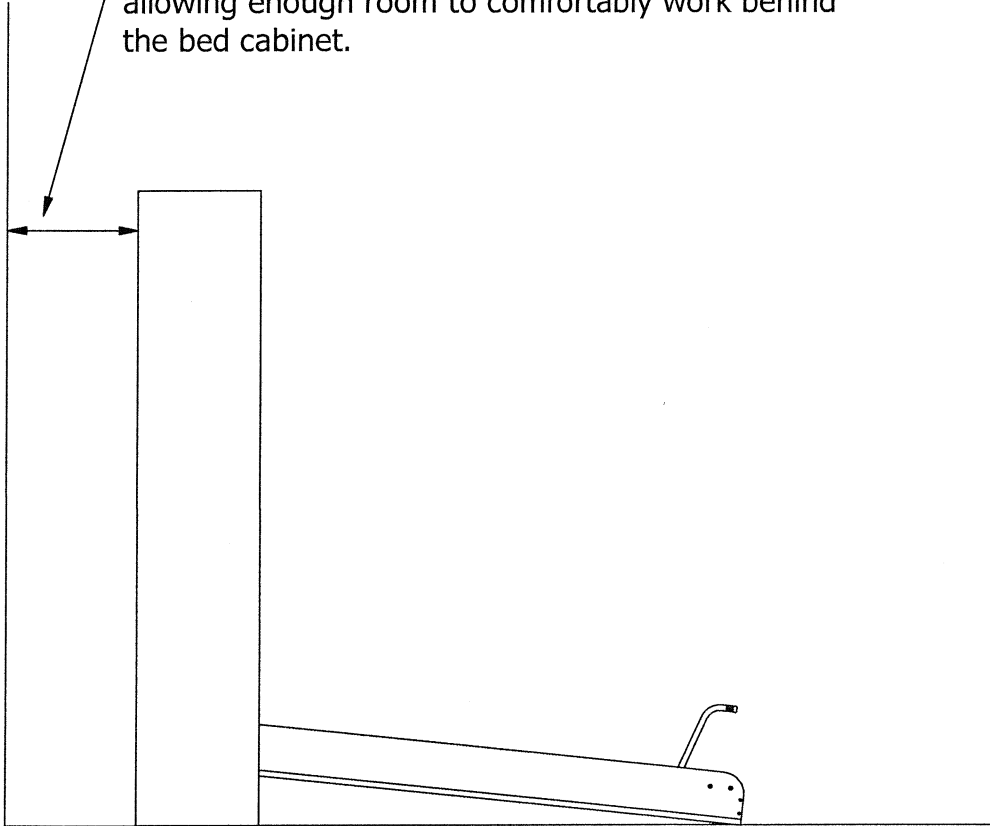

STEP 12:

With a helper holding the bed cabinet, allow the bed to recess back into the cabinet about three (3) inches or more.

At this point, the Gas Spring can be installed. Simply snap the Gas Spring on the bottom (bed frame) end first, then the top (bed cabinet) end. BE SURE TO ORIENT BOTH Gas Springs CORRECTLY by referring to the label on each Gas Spring, ("MOUNT THIS END UP")

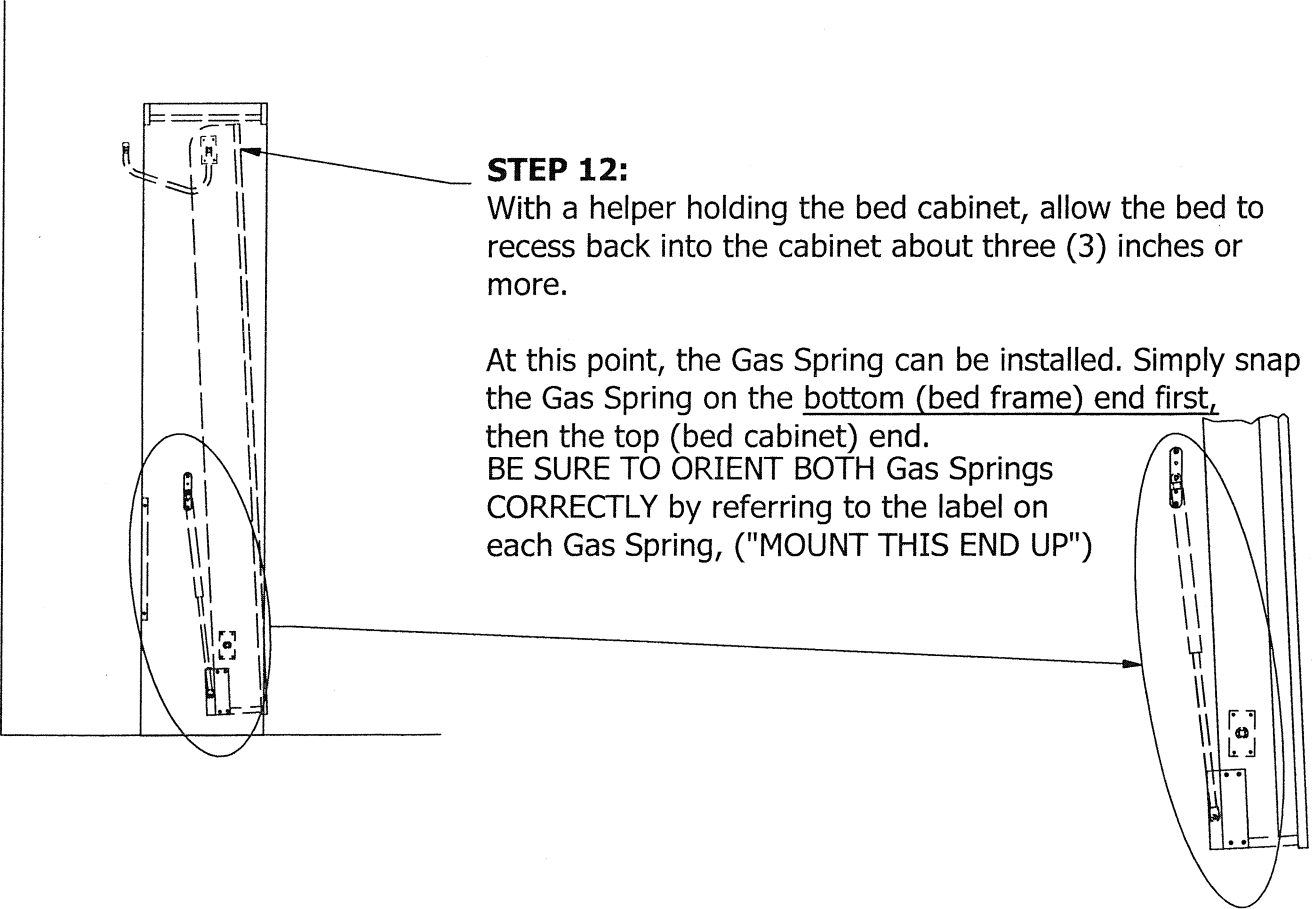

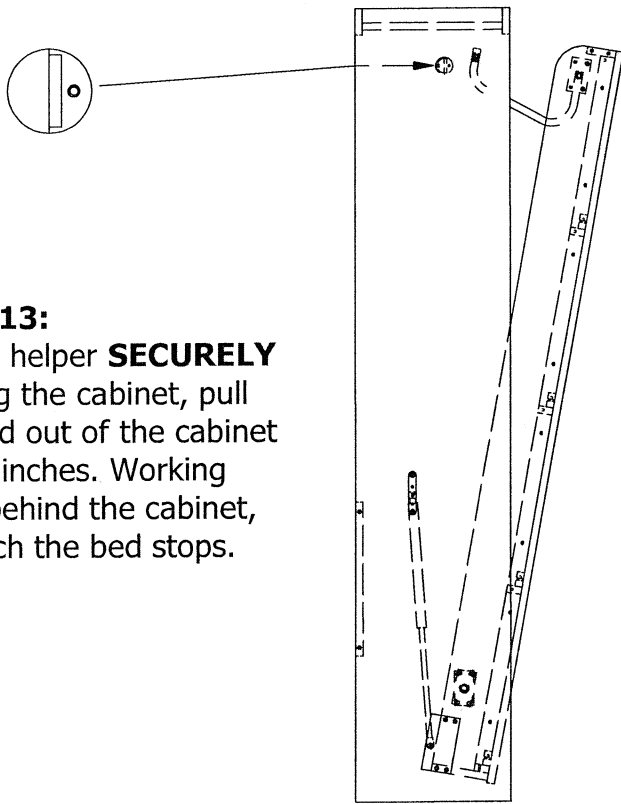

STEP 13:

With a helper **SECURELY** holding the cabinet, pull the bed out of the cabinet 4 to 5 inches. Working from behind the cabinet, reattach the bed stops.

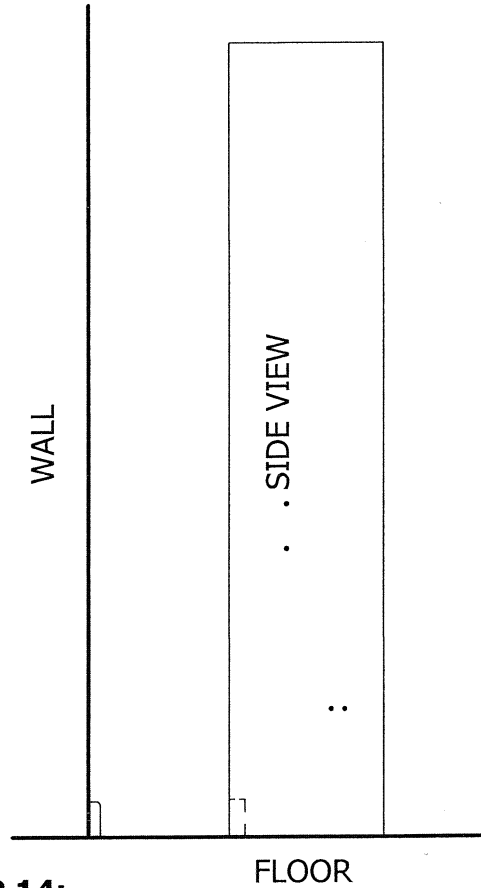

STEP 14:

If the room has existing base molding, make a cut at the bottom rear of the cabinet verticals to accommodate the existing base molding. If room does not have base molding, simply place cabinet flush against wall.

STEP 15:

After assuring that the top and bottom of the bed cabinet are against the wall, center the face panel between the verticals by placing a piece of folded cardboard between the face panel and each of the two verticals as illustrated.

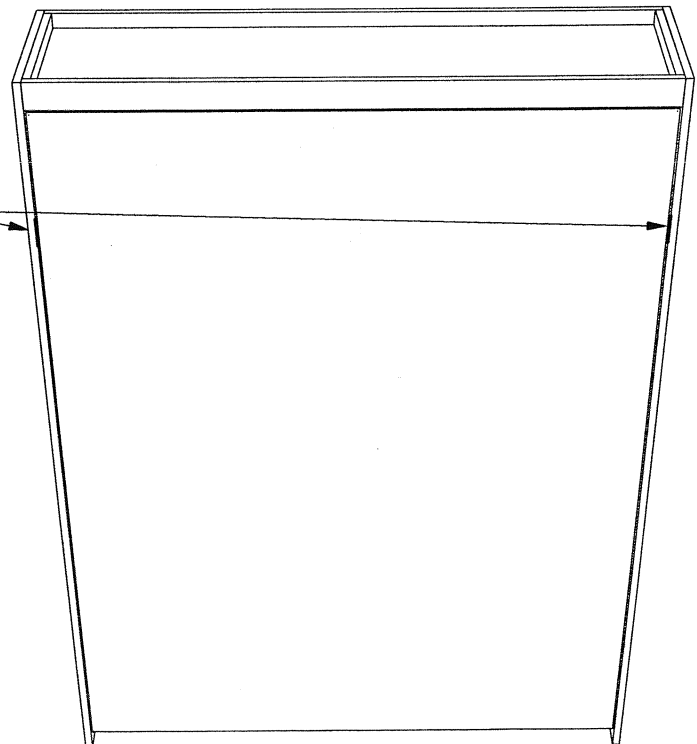

STEP 16 IS VERY, VERY IMPORTANT!!! YOUR BED MUST BE SECURELY AND CORRECTLY ANCHORED TO THE WALL to assure proper operation and to avoid possible injury.

NOTE: When the bed is lowered, it wants to pull the bed cabinet down with it, so the bed cabinet **MUST** be securely anchored to the wall using the correct fasteners for your type of wall.

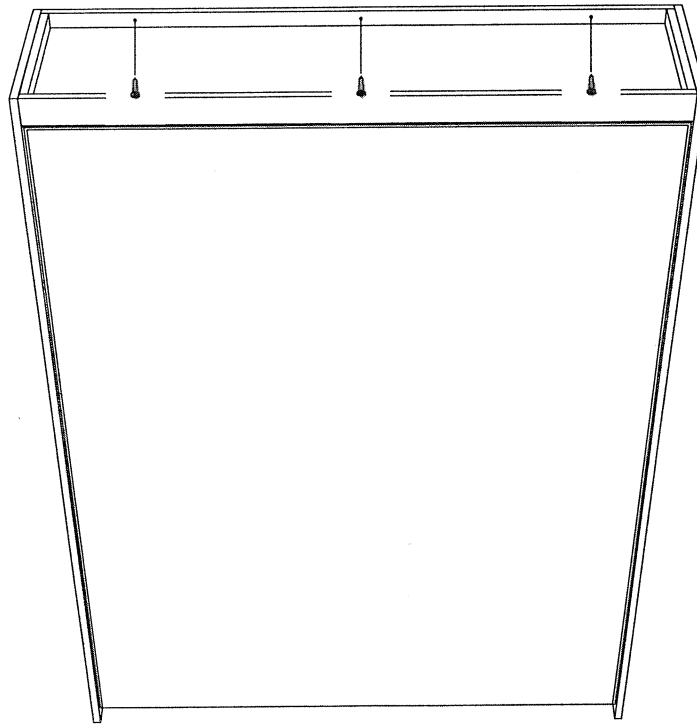

See STEP 16 on PAGE 10 for Anchoring Instructions —→

STEP 16: MOUNTING THE BED CABINET TO THE WALL

If the wall has **WOOD** studs, use 3" COARSE THREAD drywall screws or 3" lag screws:

Locate and mark the centers of the studs in desired wall location using a good studfinder.

Drill three (3) pilot holes through the rear rail of the Bed Header into the wall for a twin or full size bed and four (4) for a queen size bed.

Drive three (3) 3" drywall screws or lag screws through the rear rail of the Bed Header into the studs for a twin or full, and drive four (4) screws for a queen size bed.

If the wall is **CONCRETE, MORTAR OR BRICK** construction, use masonry screws:

Drill three (3) pilot holes through the rear rail of the Bed Header into the wall for a twin or full size bed and four (4) for a queen size bed.

Using a 5/32" 4" concrete drill bit, drill through the pilot holes into the wall two (2) inches deep. Anchor the bed by screwing 3/16" x 2-1/4" masonry screws through the rear rail of the Bed Header into the wall.

If the wall has **METAL** studs, use 3/16" x 4" toggle bolts:

Locate and mark the centers of the studs in desired wall location using a good studfinder.

Drill three (3) pilot holes through the back rail of the Bed Header into the wall for a twin or full size bed and four (4) for a queen size bed.

Using a 9/16" drill bit, drill holes at the pilot holes through the metal studs. Be sure you drill through the studs. Insert the toggle bolt screws through the pilot holes in the rear rail of the Bed Header. Now thread the toggle wings on the screws. Fold the wings back completely and push the wings through the metal studs until the wings spring open. Pull the Header Rail back to hold the wings against the inside of the stud and tighten the screws with a screwdriver.

NOTE: See STEP 18 PAGE 11 for instructions on how to adjust your bed to balance correctly.

STEP 17:

Holding the BED FACE PANEL in the down position, place the mattress on the bed and secure with ELASTIC RETAINING STRAPS.

STEP 18: When lowering the BED FACE PANEL with the mattress, it may seem very difficult. If the bed has too much lifting power, i.e. - wants to close - you can easily decrease the bed's lifting power by using a socket wrench or driver.

Turn the Hex Head to the right to move the ball stud to a smaller number - from five to four, or four to three. Be sure to adjust BOTH SIDES equally.

If your BED FACE PANEL hangs out of the CABINET when the bed is closed, turn the Hex Head to the right to move the ball stud to a smaller number as described above, making sure that you adjust BOTH SIDES equally.

REMEMBER: SMALL adjustments make **BIG, BIG** differences in your bed's lifting power.

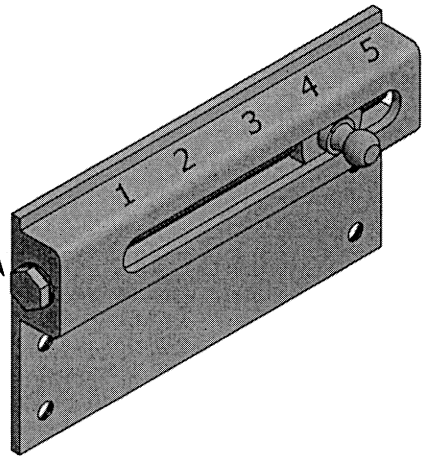
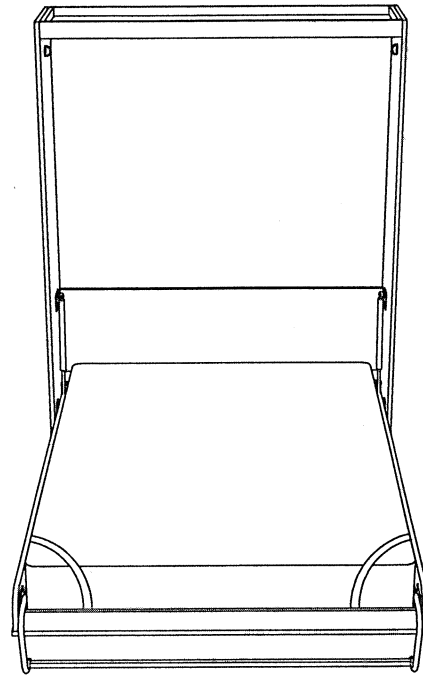

Narrowest Gap

STEP 19:

Close bed. If the gap around the bed is uneven, push or gently kick the base of the CABINET on the side with the **NARROWEST** gap until desired gap is obtained.

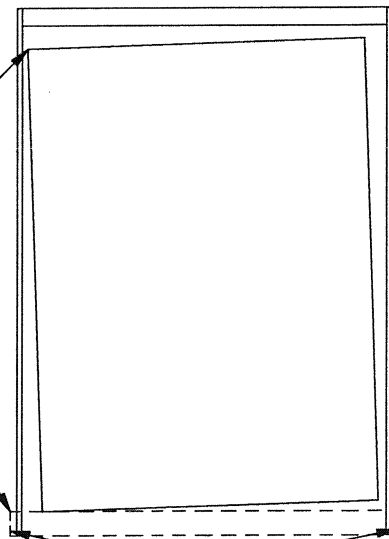
**STEP 20:**

Close bed. Apply base molding (if applicable) from outside of vertical to outside of vertical.

PROBLEM SOLVING

Q: The gas spring won't hand-compress... has it "frozen up?"

A: The design and construction of the gas spring's internal parts won't allow it to "freeze up." Each gas spring contains a significant amount of pressure, so they cannot be compressed by hand. Please refer to ASSEMBLY BOOKLET, page 7 - step 12.

Q: The bed is very hard to open and it wants to spring closed.

A: When lowering the **BED FACE PANEL with the MATTRESS**, it may seem very difficult. If the bed has too much lifting power – i.e. – wants to close – you can easily decrease the bed's lifting power by using a socket wrench or driver. Turn the Hex Head to the right to move the ball stud to a smaller number – from five to four, or four to three. Be sure to adjust BOTH SIDES equally.

Q: I've assembled the bed and attached it to the wall, but the bed face panel sags out of the cabinet... What do I do now?

A: If your BED FACE PANEL hangs out of the CABINET when the bed is closed, turn the Hex Head to the right to move the ball stud to a smaller number. Small Adjustments make BIG, BIG, differences in your bed's lifting power. Be sure to adjust BOTH SIDES equally.

REPLACING THE COUNTER BALANCE GAS SPRING

DO NOT ATTEMPT to remove the gas spring by any other means than the one described in the step below.

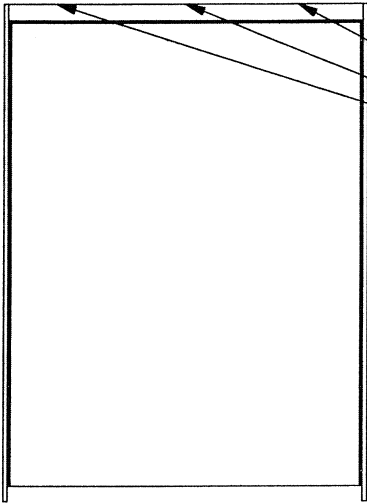

STEP 1.

Remove the mattress and with the bed in the upright closed position, remove the anchor screws from the top of the bed cabinet. **Do not** remove the anchor screws with the bed in the open position.

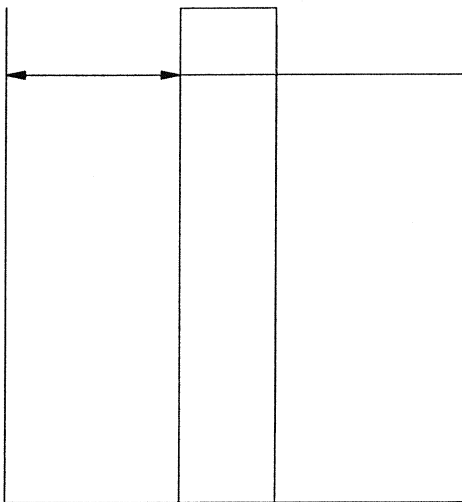

STEP 2.

Place the bed cabinet 2 to 3 feet away from the wall, allowing enough room to comfortably work behind the bed cabinet.

STEP 3.

With a helper **SECURELY** holding the bed cabinet, lower the bed 4 to 5 inches out of the cabinet.

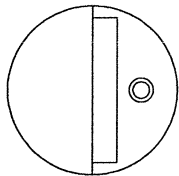

STEP 4.

Working from the back of the bed, remove the screws and bed stops.

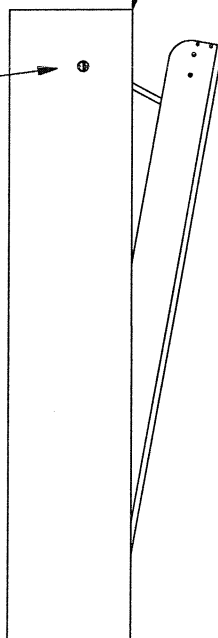

STEP 5.

With your helper **STILL HOLDING THE BED CABINET**, allow the bed to pull back into the bed cabinet. It will recess about 3 inches into the bed cabinet.

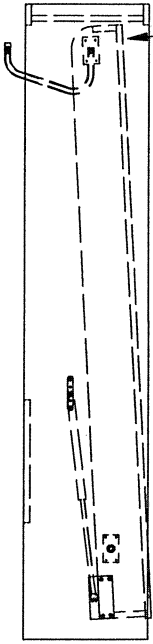
**STEP 6.**

At this point, the gas springs can be removed and replaced **ONE AT A TIME**.

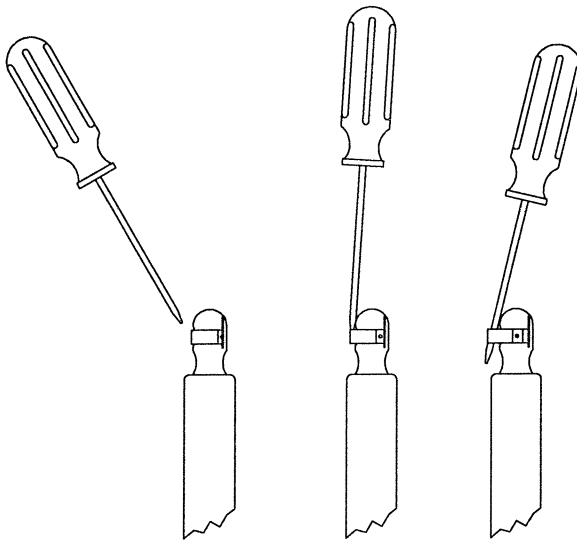
**STEP 7.**

With the tension off of the gas spring - i.e. - with the gas spring fully extended - use a flat blade screwdriver to gently pry up on the spring clip located around the plastic head of the gas spring. Now just pull the gas spring off. **REMEMBER:** the spring clip isn't removed, just opened.

STEP 8.

At this point, the new gas spring can be installed. Simply snap the new gas spring on the lower ball stud located on the bed rail - then the upper ball stud located on the bed vertical. **BE SURE TO ORIENT THE GAS SPRING CORRECTLY** by referring to the label on the gas spring. ("MOUNT THIS END UP")

STEP 9.

Repeat on the other side of the bed.

STEP 10.

Replace both bed stops and screws.

STEP 11.

Place the bed cabinet back against the wall and replace the screws, **MAKING SURE THE BED IS SECURELY FASTENED TO THE WALL.**

