

Note: All baths in Australia come standard **without** an overflow.

Shropshire SHR-N-SW-NO

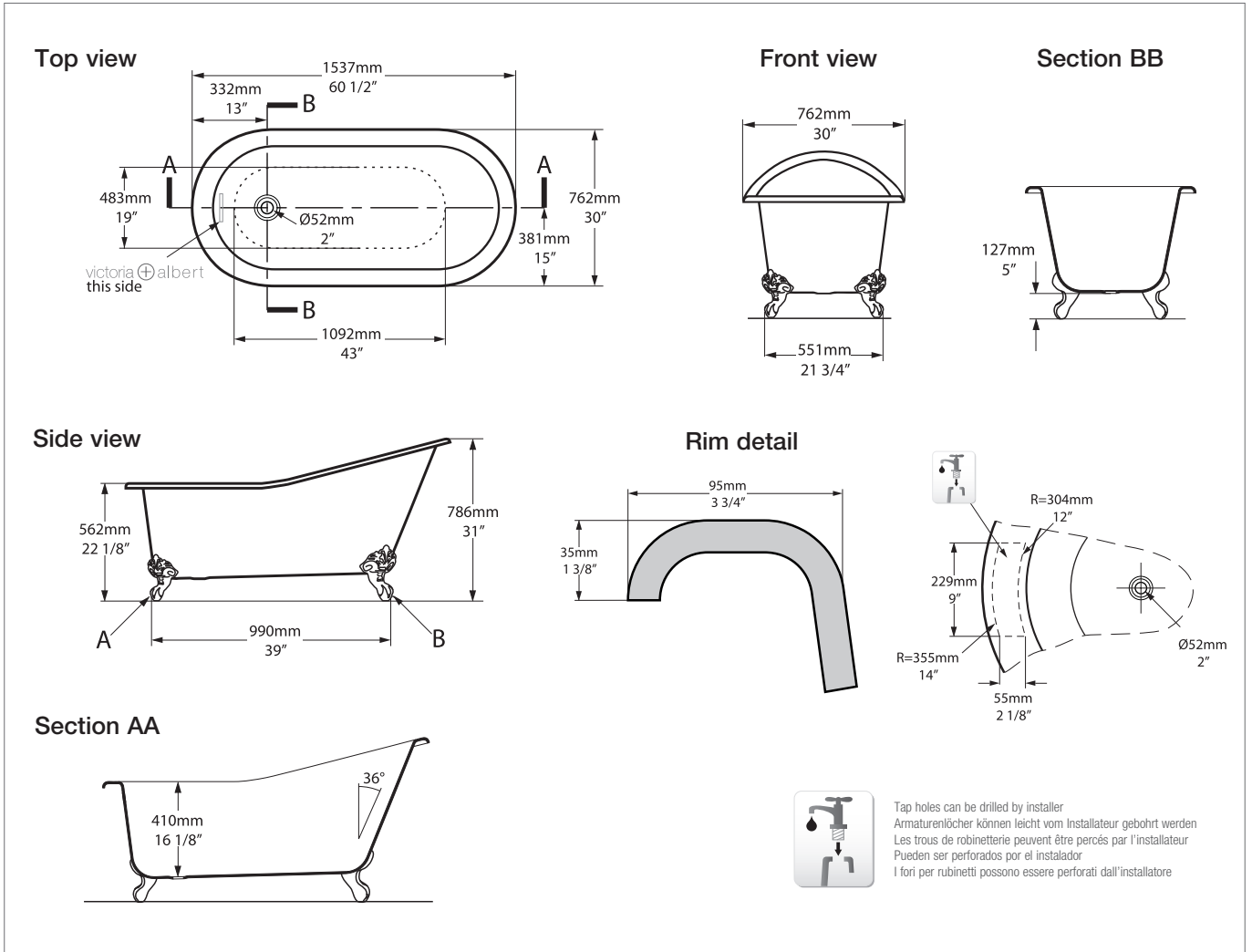

Bath shown with optional K50 waste kit



- WH White Metal, Metall Weiß, Métal Blanc, Metal Blanco, Metallo Bianco
- PC Polished Chrome, Chrom Poliert, Chrome Poli, Cromado brillante, Cromo Lucidato
- PB Polished Brass, Messing Poliert, Laiton Poli, Latón Pulido, Ottone Lucidato
- BN Brushed Nickel, Nickel Gebürstet, Nickel Brossé, Niquel Satinado, Nickel Spazzolato
- PN Polished Nickel, Nickel Poliert, Nickel Poli, Niquel Brillante, Nickel Lucidato
- SW QUARRYCAST™ White, QUARRYCAST™ Weiß, QUARRYCAST™ Blanc, QUARRYCAST™ Bianco, QUARRYCAST™ Bianco

Feet are supplied in the same colour as bath as standard.
 Standard werden die Füße in der gleichen Farbe wie die Wanne geliefert.
 Les pieds fournis seront de la même couleur que la baignoire.
 Como estándar, los pies se suministran en el mismo color que la bañera.
 I piedini sono forniti nello stesso colore della vasca.

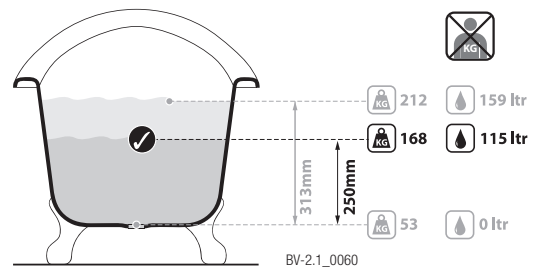

Recommended wastes: K-12-xx / K-50-xx

*All measurements subject to +/-5% tolerance

25 years

Guaranteed for residential use for 25 years*
 25 Jahre Garantie bei privater Nutzung
 25 ans de garantie pour un usage domestique
 Garantía de 25 años para uso domestico
 La sicurezza garantita per uso residenziale per 25 anni

8 years

Guaranteed for commercial use for 8 years*
 8 Jahre Garantie bei gewerblicher Nutzung
 8 ans de garantie pour un usage commercial
 Garantía de 8 años para uso comercial
 La sicurezza garantita per uso commerciale per 8 anni

- QUARRYCAST™ white products only. Paint finish exterior guaranteed for 2 years.
- Nur auf weiße QUARRYCAST™ Produkte. Auf Aussenlackierung gibt es 2 Jahre Garantie.
- Uniquement pour les produits en QUARRYCAST™ blanc. Pour les finitions extérieures peintes la garantie est de 2 ans.
- Solo sobre productos en QUARRYCAST™ blanco. Acabados de pintura exterior tienen una garantía de 2 años.
- Solo per prodotti bianchi in QUARRYCAST™. Finitura esteriore dipinta garantita per due anni.



Massachusetts Code: Approved
 cJPC listing by IAPMO: File No. 6574