

FLOOR TO CEILING TOWEL RAIL

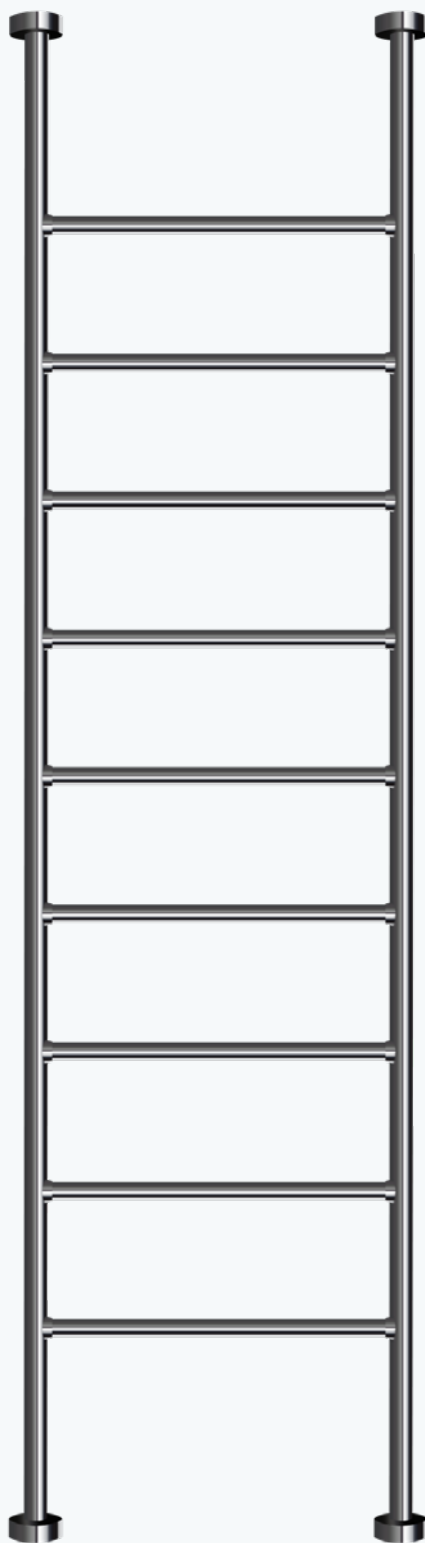

HYDROTHERM
TOWEL RAILS

ver. 2021-3

FLOOR TO CEILING TOWEL RAIL

Hydrotherm's signature series, the Floor to Ceiling range is a bold symbol of class, supremacy and style. A centrepiece for designer bathrooms, these models signify superior luxury, whilst generating clean radiant warmth. The ultimate bathroom accessory...

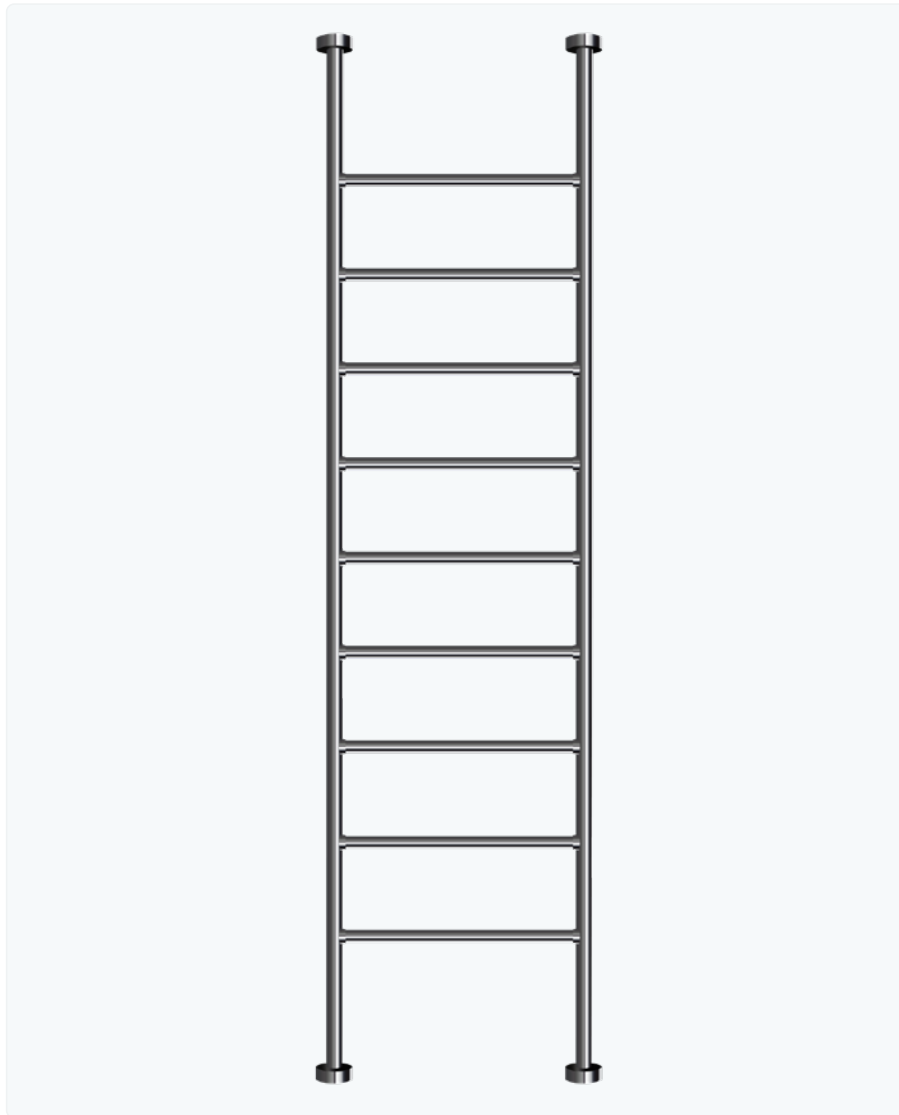

FC MODEL

Maximum Height

3000mm

Available Widths

500mm, 600mm, 700mm 800mm

Wattage

250 - 300 Watt

KEY FEATURES

Replaceable Element

Heating element easily replaced

Classic Design

Centrepiece for designer bathrooms, signifying superior luxury, while generating clean radiant warmth

Copper Tube

Ensures ultimate thermal conductivity and radiant heat

Local Product

100% Australian owned and manufactured

STANDARD SPECIFICATIONS

Tube Diameter

Vertical 38mm /
Horizontal 25mm

Materials

Copper tube with
brass fittings

Element

Low wattage, water
element replaceable

Power Cable

Floor / Ceiling

Safety Rating

IPX5 (allows for installtion
in zone 1 & 2 of bathrooms)

FINISHES & POWDER COAT OPTIONS



Polished Chrome



Matt Black



Brushed Nickel

Custom Colours available upon request



**PROUDLY AUSTRALIAN
MADE AND OWNED**

Widths measured from centre to centre of vertical tube. Allow an extra 75mm in total when measuring total width of unit mounted.

FC MODEL Electric or Non-heated

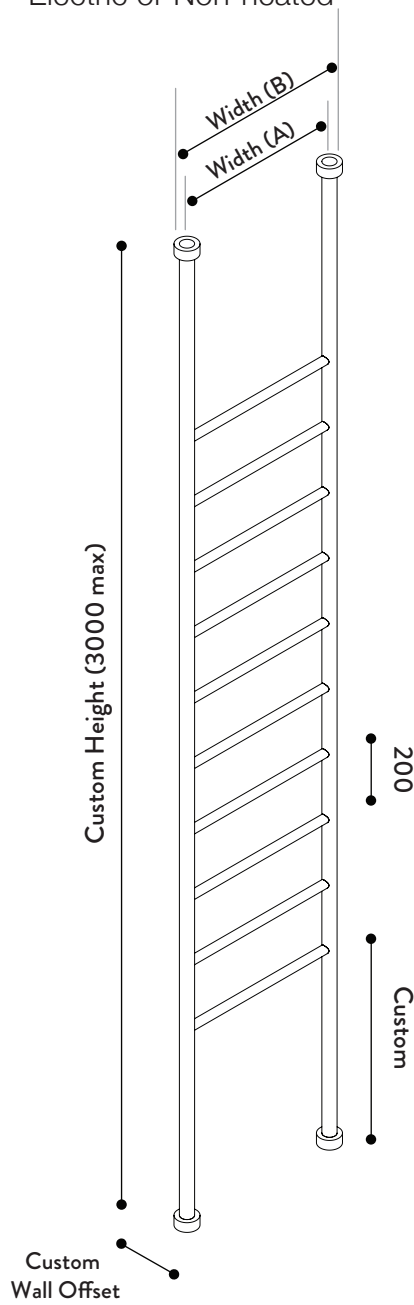

SPECIFICATIONS

Maximum Height

3000mm

Available Widths

500mm, 600mm, 700mm 800mm

Tube Diameter

Vertical 38mm / Horizontal 25mm

Safety Rating

IPX5 (allows for installation in zone 1 & 2 of bathrooms)

Finishes

Electroplate / Powder Coat

Output

250 - 300 Watt

Materials

Copper tube with brass fittings

Standards

AS/NZS:3350

KEY FEATURES

Replaceable Element

Heating element easily replaced

Classic Design

Centrepiece for designer bathrooms, signifying superior luxury, while generating clean radiant warmth

Copper Tube

Ensures ultimate thermal conductivity and radiant heat

VARIATIONS

Electric	Height	Width (A)	Width (B)	Chrome Wattage	P/Coat Wattage
FC/500	Custom	500mm	540mm	200 Watts	300 Watts
FC/600	Custom	600mm	640mm	250 Watts	300 Watts
FC/700	Custom	700mm	740mm	250 Watts	300 Watts
FC/800	Custom	800mm	840mm	300 Watts	300 Watts



PROUDLY AUSTRALIAN
MADE AND OWNED



3 YEAR
ELECTRIC ELEMENT
MANUFACTURERS WARRANTY



10 YEAR
CONSTRUCTION & FINISH
MANUFACTURERS WARRANTY

INSTALLING BRACKETS

STEP 1 - PRE-DRILLING

1. Position flanges onto rail and place on floor/ceiling. Mark Screw holes with pencil
2. Remove rail and pre-drill screw holes with drill.

STEP 2 - POSITIONING RAIL

1. Slide flange cover plates over legs at top and bottom.
2. Relocate rail in desired position with flanges connected (loose).
3. Using screwdriver/drill secure screws in pre-drilled holes. Both top and bottom.
4. Screw in grub screws with allen key provided.
5. Push Down on cover plates at either end to secure into place.
6. Towel Rail is now ready to be connected by licensed electrician.

Please note:

All Hydrotherm Floor to Ceiling Towel Rails are supplied pre-filled with water.

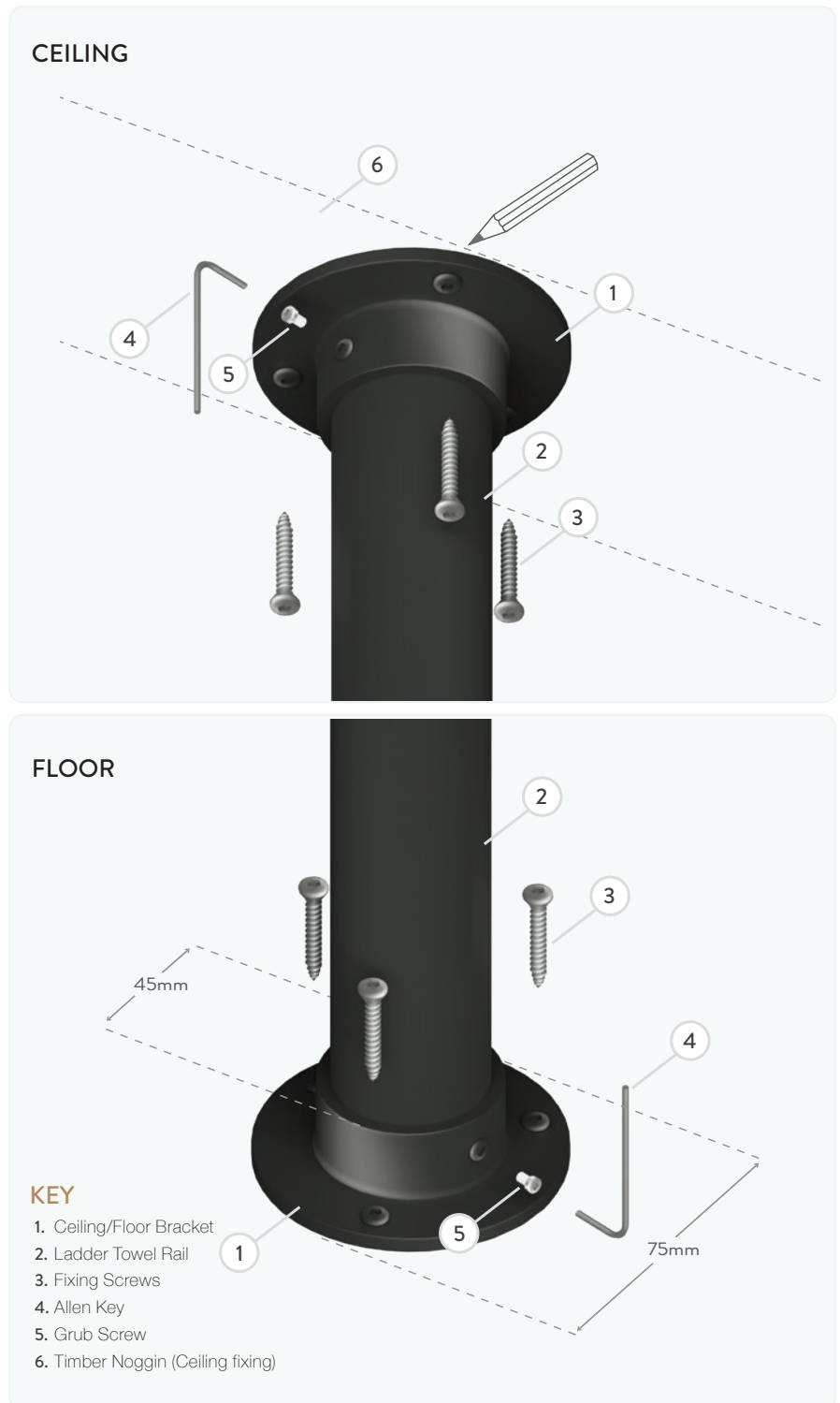

WARNINGS

TOWEL RAILS MUST ALWAYS BE INSTALLED WITH THE ELECTRIC ELEMENT POSITIONED AT THE BOTTOM OF THE UNIT FOR CORRECT HEAT TRANSFER

Hydrotherm take pride in the fact that all rails are individually hand made. Due to this fact some measurements may not be exact. **PLEASE READ INSTRUCTIONS CAREFULLY** and do not force towel rail into bracket if position of wall flange is not accurate.

In order to avoid hazards for young children, this appliance must be installed so that the lowest rung is at least 600mm from the floor.

WIRING OPTIONS

The Hydrotherm FC - Series Electric Towel rails come pre-filled with water, and with electric elements already fitted.

CONCEALED CONNECTION - (FLOOR / CEILING)

The electric element can be recessed up inside the vertical leg of the towel rail with its cable protruding from either the top, or bottom of the unit. The connection can be made by a qualified electrician in either the ceiling cavity, or under the floor if access is available. **Refer Concealed Wiring page of this specification for further detail.**

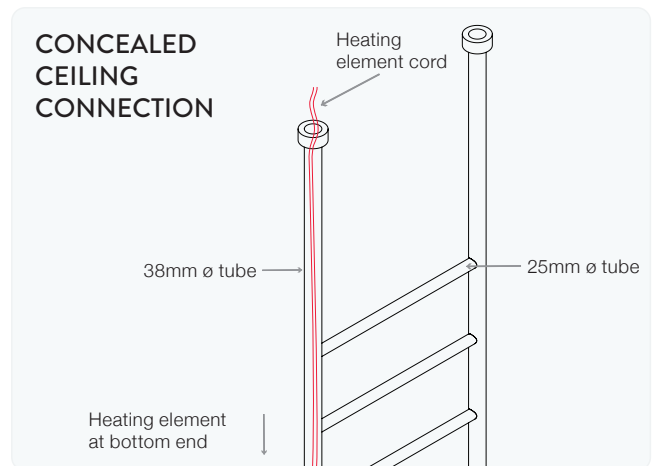
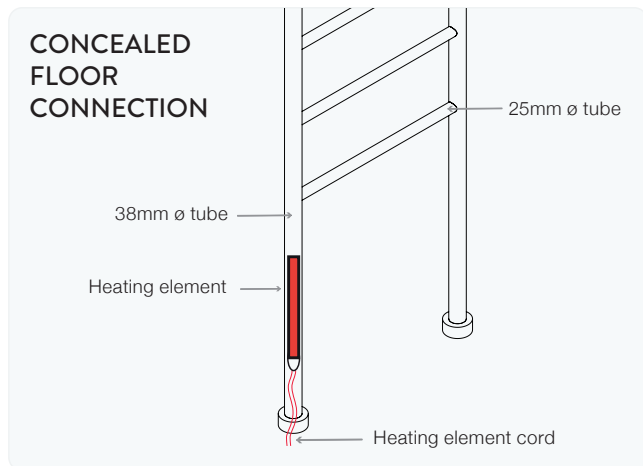

HARD WIRING

Heating element must always be positioned at the bottom of the unit for correct water flow, and heat transfer.

Hydrotherm recommends that all hard-wired heated towel rails be connected to a light switch or timer. Connecting hard-wired heated towel rails to a light switch or timer will prolong the life of the electric element and reduce energy consumption.

Contact your local hardware store, electrical wholesale outlet, or a qualified electrician to discuss what timers and switches may suit your specific needs best.

All Hydrotherm Elements carry the following approvals.



Elements have a built in thermostat and internal cut out ensuring safety and energy efficiency. All Hydrotherm electric elements can be supplied as 240v or 110v. All electric elements are replaceable and can be easily changed over.

CONCEALED IN FLOOR WIRING

A custom option is available to have the element installed inside the bottom leg of the towel rail. This can be made to order on the Floor to ceiling series. **THIS OPTION MUST BE SPECIFIED ON ORDER.**

Wiring through the floor must be organised prior to laying floor tiles. A cable flex connected to an isolating switch or timer must be bought up through a 10mm hole in the floor for connection in the bottom leg of the towel rail.

DO NOT MAKE THE HOLE IN TILES LARGER THAN 20mm.

It is recommend that the wiring be connected to an RCD and silicon applied to the leg of the rail after wiring connection has been made.

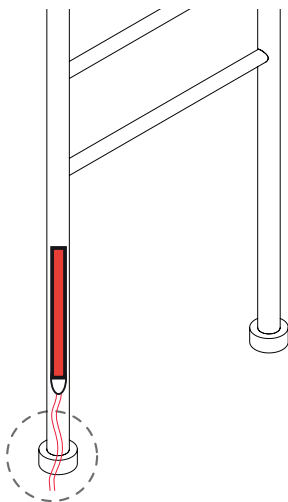

INSTALLING ON A CONCRETE SLAB

If your home is on a concrete slab, a 20mm conduit line must be run from the isolating switch to the towel rail. This can be placed underneath tiling or between mesh.

It is essential that the electrician leaves some slack in the cord inside the bottom leg of the towel rail for disconnection in the future

For further information please contact Hydrotherm.

KEY

1. Heating Element inside 38mm tube.
2. Electric cable connection inside tube (Allow extra slack)
3. Finished surface (eg. Tile)
4. Floor slab
5. 8mm ø Power cable (1.5m long).
Bring up cable flex through 10mm hole in floor tiles to make internal connection.*
6. 20mm conduit between tile and slab*

***Note.** Connection to an isolation switch or timer must be laid prior to installing floor tiles



WARNING

Heating element must always be positioned at the bottom of the unit for correct water flow, and heat transfer.

HYDROTHERM ELEMENTS

The Hydrotherm thermostatic electric element is specially designed with a built in safety device that switches it off to avoid overheating.

The element is placed in either the left or right (vertical rail), at the bottom of the towel rail. It must always be placed at the bottom end of the towel rail for correct water flow and heat transfer.

The element is designed to reach an internal temperature of approximately 55 degrees celcius, and to switch off or cool down, so as to maintain the internal water temperature.

Depending on the size of the model, Hydrotherm Towel Rails will require approx. 20min - 60min to reach their max. heat output

CHANGING ELEMENTS



WARNING

Rail must be disconnected by qualified electrician.

Please note: Due to the size and weight of this unit, it is advisable that two people carry out the below process

1. Using an allen key remove rail from floor and ceiling mounts.
2. Lay rail on its side so element (cord) is facing upwards (see drawing)
3. Remove old element by loosening hex nut and unscrewing with 18mm x 19mm tube spanner.
(Have towel and bucket accessible to collect any spilling water).
4. Replace new element by screwing in firmly with spanner.
5. If your towel rail is a ceiling connection, you will need to pull existing element cable through rail to remove. Then re-thread new element cable when replacing.
6. If any water has been lost during process, simply unscrew top cap with flat head screw driver and fill to appropriate level (see drawing)

All Floor to Ceiling Towel Rails are supplied pre - filled with water.

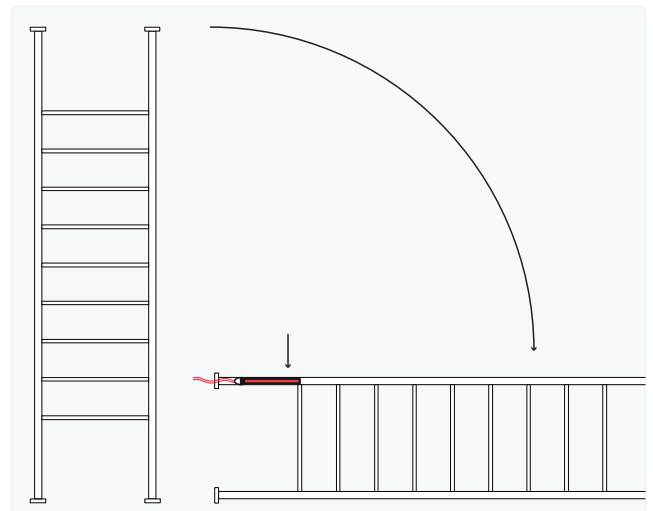

Lay Towel Rail on its side

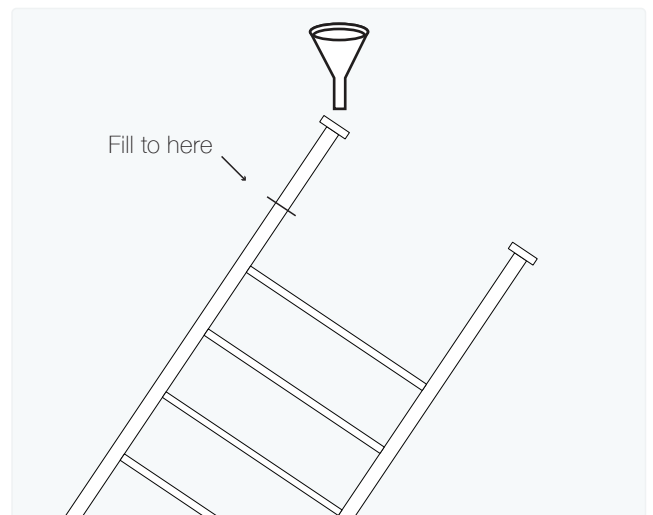

Refilling Towel Rail

CARING FOR YOUR TOWEL RAIL

Guidelines for the Cleaning and Care of your Towel Rail



INSTALLATION

Damage to tapware and bathroom accessory surfaces is often caused by the installation/removal process. So it is highly recommended that you thoroughly inspect your products out of the box, before they are installed. Ensure your tradespeople take special care when handling and installing, using clean hands or gloves and washing off any plumbing product.



Under NO circumstances should a silicone sealant be used when fitting or handling. If such sealants come into contact with the product, the sealant residue MUST be thoroughly washed immediately.

Once installed, the fittings need protection until the job is finished. Cover the surfaces to avoid splatters from paint or commercial cleaning products.

CARE AND MAINTENANCE

Please follow these cleaning and care instructions to best maintain the finish of the product you have selected.

The ideal care for all fittings is to dry them with a soft cloth after each use, which will prevent mineral deposits.

Fittings should be regularly cleaned with warm water or a mild pH-neutral liquid soap and water and polished with a clean soft cloth.

A Microfiber cloth is gentle and effective for cleaning without scratching and needs only to be dampened to clean the product. Residue left by personal hygiene products such as liquid soap, tooth paste, shampoo and shower gel can cause damage. Always rinse these off the fittings with clean water immediately after use.



Under no circumstances should harsh cleaning agents containing acidic, caustic or abrasive components or citrus, bleach or alcohol based substances be used to clean these fittings and should not be allowed to remain on metal finishes.

Avoid dripping or over spraying such cleaning agents by covering the fixtures with a cloth or towel, metal finishes splashed with these products should be immediately rinsed with clean water and dried. Do not use abrasive cloths, scouring pads, scrub sponges, steel wool etc.

HOMEOWNERS GUIDE TO PLATED FINISHES

NOTE: Scouring, steel wool, Scotchbrite, powder or abrasive cleaners should not be used on any plated finishes. This does not apply to uncoated bare brass.



CHROME: The most durable of the electroplated finishes, cleaning as per the guidelines above.



BLACK CHROME: High Gloss electroplated finish, not as resistant to scratching or scuffing as standard chrome. Cleaning and care as per guidelines above.



MATTE BLACK CHROME: Low Gloss electroplated finish with a microscopically rough surface which gives the matte appearance. Cleaning as per guidelines above. Avoid the use of waxes or polishes as they will fill the surface and give the part a polished look.



NICKEL AND BRUSHED NICKEL: Electroplated finishes known as "living finishes" which over time will develop an individual patina, giving it a distinctive classical look, however nickel finishes do require regular care. It is important to clean nickel finishes after use to prevent tarnishing. Water should be dried off and prevented from building up and forming hard water spots (which if left can be difficult to remove). It is highly recommended to clean your tapware regularly as per the guidelines above.



GOLD: Products should be only cleaned with a microfiber cloth, warm water and pH neutral liquid soap as per guidelines above.



UNCOATED BARE BRASS: As a living finish, un-lacquered brass will mature over time to develop a patina and unique character, typical of old brassware. Always have clean hands when handling brassware. All uncoated bare brass can be cleaned with mild soap and water which will not alter the aging process. Polished uncoated bare brass that has been buffed to a shiny finish; over time the polished brass will garner a patina and the surface lose some of its brightness. Brass fittings can be cleaned routinely with mild soap and water which will not alter the patina development. If desired the shine can be restored with a very mild abrasive cleaner like Brasso.



SATIN UNCOATED BARE BRASS: Has a brushed surface which reduces the gleam on the surface. A brushed finish is more susceptible to staining or marks from chemicals or acids as the surface has small 'scratches' which pick up the stain. Therefore, establish a simple routine of rinsing off the tap with warm water and drying it, if it is splattered with cooking acids or chemicals such as toothpaste. If uneven staining occurs, this finish can be refurbished when dry with a gentle abrasive cloth – such as a non-scouring cleaning pad (eg. Scotchbrite). If the surface is polished with a metal polish this will reduce the brushed effect.



LACQUERED FINISHES: This is an acrylic lacquer topcoat applied to provide additional protection to soft or low corrosion resistance coatings such as rose gold. Simply wiping and drying with a soft cloth will maintain the finish. Never use abrasives of any nature as these will scratch and wear the coating. Follow guidelines as set out above.

ANTIQUÉ FINISHES: Refer to specific guidelines.

THE HYDROTHERM WARRANTY

Our warranty covers the repair or (At Hydrotherm's discretion) the replacement of any items flawed through impaired workmanship or materials. Hydrotherm Towel Rails possess a 10 year guarantee on the integrity of their construction and finish. The internal heating element carries a 3 year warranty only.

Warranty period commences from date of purchase. Please ensure proof of purchase information is preserved. All warranty issues are to be initiated through original point of purchase, so that an official service call can be lodged through the appropriate channels. From here our After Sales Service Team will act accordingly.

IMPORTANT INFORMATION

All Hydrotherm Heated Towel Rails are supplied with water, unless otherwise specified. This unit is not designed to be used as a ladder. No responsibility will be taken by Hydrotherm Australia Pty. Ltd for incorrect installation. All warranty will be void if instructions are not followed.

ELECTRIC MODEL

Electric connection must be installed by a qualified electrician. All Hydrotherm Towel Rails carry an IPX5 rating for use in wet areas. If the electrical cable is damaged, the entire element must be replaced. When connecting, element must be positioned at the bottom of the towel rail. If installed incorrectly, Towel rail will not operate effectively and may cause damage to the element.

WARRANTY WILL BE VOIDED FOR THE FOLLOWING REASONS

- Failure to provide adequate proof of purchase or similar documentation.
- Hard wired towel rails not installed by a licensed electrician.
- Towel Rails not installed in accordance with State and or National standards.
- Failure to install towel rail in accordance with manufacturers instructions.
- Product used for incorrect applications.
- Service, repairs or alterations undertaken without manufacturers written approval.
- Damage to finish which arise from installation or post installation.
- Failure to adhere to manufacturers care and cleaning directions.



3 YEAR
ELECTRIC ELEMENT
MANUFACTURERS WARRANTY



10 YEAR
CONSTRUCTION & FINISH
MANUFACTURERS WARRANTY

HYDROTHERM 100% AUSTRALIAN MADE AND OWNED

Vogue Spas & Bathrooms



**PROUDLY AUSTRALIAN
MADE AND OWNED**