

Products Warranty - Australia

For warranty details see our website:

<https://www.faucetstrommen.com.au/warranty/>

Installation Guide **IG 017**

Release Date: 15.02.23

Progressive Wall Mixers



Suits Models:

30908, 30948, 33730, 33880, 33887, 35346, 35360

Important requirements:



Must be fitted in accordance with AS/NZS 3500 by qualified plumber



Mains 500kpa regulator must be fitted



Maximum hot water temp. 65°C



Water lines must be flushed prior to connection



Only clean municipal water supply. No bore, dam or hard water without filtration & treatment

Cleaning

Clean only with a soft microfiber or similar cloth and warm clean water. Ensure that the cloth is clean and free of any grit or chemical. Dry tap off with a soft clean cloth. Ensure that your tap is not subject to any chemicals, building grit or any type of abrasive or polish. For care of special finishes please visit our website.

Maintenance

Aerators may need to be flushed from time to time if flow diminishes or stream pattern deteriorates. For Pegasi & Cascade mixers, use the aerator key provided to unscrew the aerator, you will notice a "castle" pattern around the edge of the aerator, the key engages with this enabling you to unscrew the insert easily. For Zeos models, use the aerator key to unscrew the aerator housing, you will then be able to pop the insert out the top of the housing. Rinse off the upper face of the insert with running water and gently brush clean with an old toothbrush to remove any debris before refitting the aerator.

Rough In

1. Ensure that the in-wall nogging depth is correct and that the nogging is plumb. Position the noggin such that the front face of the noggin is **62mm** behind the **front face** of the **finished tiled surface**. (note that there is a maximum of **± 8mm adjustment** at fit off). [See diagram A](#)
2. Fix the body to the stud with the **outlet facing upwards**, Cold inlet to the right & hot inlet to the left. Mount the plate level. [See diagram B](#)
3. Connect the Hot supply to the inlet port on the left marked "H" and the Cold supply to the right side Inlet marked "C" and connect the outlet line to the top outlet port.
4. Once plumbing is all connected pressure test the system. **Do not exceed 500kpa pressure testing** whether dynamic or static. Testing over 500 kpa will void the warranty for this product.
5. The body is fitted with a black shroud (also a tile guide). This should always remain in place. The red dust cover may be removed for testing, but otherwise should remain in place.
6. Wall sheeting and tiling can be laid **close to the shroud** and waterproofing membrane and grout can be adhered to the shroud.
7. An indicator on the end of the shroud shows the range that can be accommodated at fit off for the finished tile face position.
8. When tiling, note that the dress ring is **51mm diameter**, so be sure to tile close to the shroud so there are no gaps showing after fit off. [See diagram C](#)

Fit Off

1. Remove excess tile grout from around the shroud to allow a flush fitment of the cover ring.
2. Remove the red dust cap and use a sharp knife to cut away the black shroud that protrudes past the finished tile surface and ensure that the area around the shroud is flat and free of protrusions.
3. Place the red fiber washer onto the locking sleeve and screw the sleeve onto the body until up against the tiles. Nip up gently being careful not to damage or crack the tiles. [See diagram C](#)
4. Note that there are **2 splined adaptors** supplied. For shallower installations use the shorter adaptor, for deeper installations use the longer adaptor. (tip, if you had to cut off more than 8mm of black plastic shroud, use the short adaptor, if you cut off less than 8mm of shroud use the long adaptor)
5. Note that the valve spline and the adaptor spline have **un-splined segments** it is important that these **properly mesh** and align when the adaptor is fitted.
6. Ensure that the valve is in the off position (all the way anticlockwise), then fit the adaptor to the valve spline such that one of the **milled slots is facing up** and the other to the left.
7. Ensure that the adaptor is oriented such that the grooved face is facing out, [See diagram D](#)
8. Press the adaptor all the way on and fasten in place with the hex drive screw provided.
9. Note that the dress ring includes indication markings. Place the ring over the locking sleeve and position such that the "I" symbol is facing the top, then loosely fit the 3 attachment screws.
10. To ensure that the dress ring is perfectly concentric to the valve, we have supplied a round plastic **Concentricity spacer**. Slide this over the adaptor and locate it into the cover ring, then fasten the ring in place ensuring the "I" symbol is to the top.

11. Remove and discard the concentricity spacer.
12. Note that there is a pre inserted grub screw in the handle that just protrudes into the bore.
13. Place the black **slip ring** onto the step machined in the back of the handle then press the handle onto the tap with the **wave form** to the **top**. The handle should slide over the adaptor with the grub screw engaging in the slot.
14. The handle should slide on until it presses smoothly up to the dress ring, square and flat.
15. **To fasten**, rotate the handle through **90 degrees clockwise** until the waveform passes over the small **fastening hole** in the dress ring. Insert the allen key through the hole and tighten the handle by fastening the grub screw onto the adaptor.
16. The handle should now operate smoothly and freely to control the tap through 180 degrees (half a turn)
17. Progressive valves open clockwise, over the first 90 degrees of rotation the cold water opens to full flow, then from 90-180 degrees the valve goes from warm to hot.
18. Thoroughly check operation and seek assistance from Faucet Strommen should anything not be functioning to expectation.

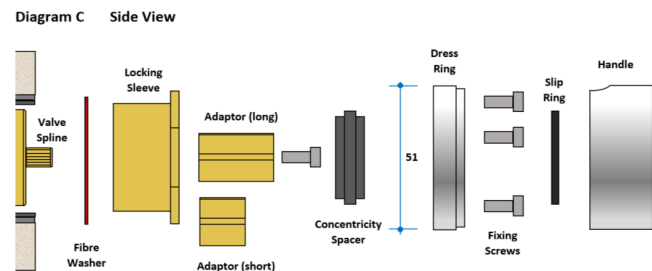
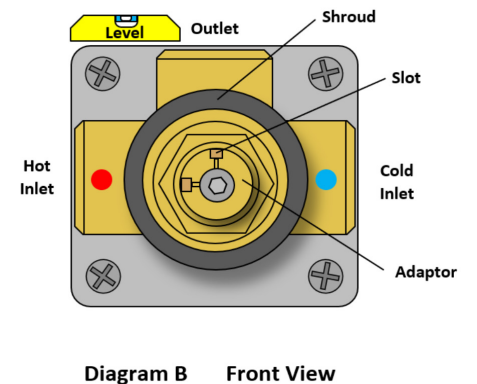
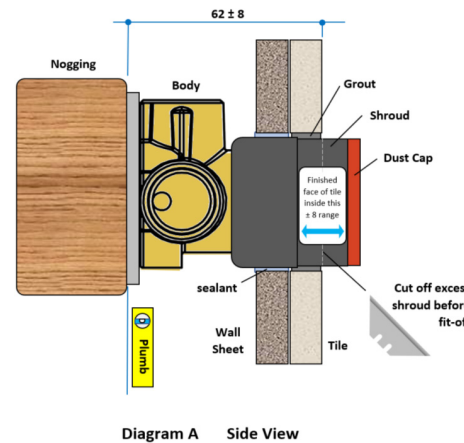

Diagram D

