

Silkstone Baths & Basins

Handling, Installation and Care



Congratulations on your purchase of a fine Silkstone Bath or Basin. This is a life investment and these instructions will help you to enjoy decades of service and enjoyment from your product.

It is important to read and understand these instructions before moving or installing your new Silkstone Bath.

Carrying & Handling a Silkstone Bath.

Engineered stone baths are heavy and should be handled in such a way as to avoid any physical injury or bath damage. A strong plywood crate is used to protect the Silkstone bath during transit. This ensures that the bath arrives in perfect condition. Each bath is thoroughly inspected before packaging at our Victoria Warehouse prior to despatch. Please ensure that the crate is not damaged in any way prior to opening it. Advise Faucet Strommen Immediately if any damage exists. (call 1800 505 116).

Take the crate to a suitable unload area using a trolley or pallet truck. Ensure the crate is kept dry and does not remain outdoors in the sun or rain. To open, remove the screws around the base of the crate and carefully lift off the entire crate sides & lid being carefully not to knock or damage the bath. Thoroughly check the bath for any damage before removing the attachment strapping. In case of any damage or defects please report immediately to Faucet Strommen on 1800 505 116. To prevent damage in handling leave the plastic wrapping on the bath until it is in position in the bathroom. Clean your hands before touching the Silkstone bath surface to avoid leaving marks.

Silkstone baths weight between 99 and 135 kg depending on the model. Ensure you have sufficient access space to move the bath into position without causing damage or injury. Lifting aids, a piano trolley or a few people may be required to move the bath into position. Please take care. Straps have been provided and may be used to assist in handling. Please ensure that the straps are in good order and that they are properly tied around the bath feet before use.

Preparing the space for the bath to stand

Carefully plan the bathroom layout before bringing the bath into position. Make sure it has suitable space to allow easy access and that the plumbing is in the correct position. Silkstone baths should be

placed on a clean, dry and robust floor. These baths can weigh 400kg when filled with water. If in doubt as to the strength of the floor contact your builder before installation.

Note that the grey areas on the drawings included on pgs 3 & 4 show the boundaries inside which the drain should be located to allow suitable connection. Silkstone baths come with a neat pop up waste and a built in overflow. The waste should be connected to the drain by a qualified plumber.

Use the adjustable feet to level the bath. Ensure that each foot is touching the floor and taking weight evenly. The bath may be lowered close to the ground, but the sides should not touch the ground or take weight. Fasten feet with the counter nuts once they are set. The small gap around the bottom may be sealed with silicone, but only after the waste is connected and it have been checked for water tightness.

Cleaning and Care for Baths & Basins

This Silkstone product should only need to be cleaned with warm water , some hand dishwashing liquid and a soft cloth. Clean directly after use and dry after cleaning to prevent soap or lime scale buildup.

Occasionally you may like to clean the bath with a suitable surface spray. Only use surface spray that is approved and tested for “solid surface baths”.

Warning – Unsuitable Chemicals/Exposure

- Do not place a silkstone bath where it will receive direct sunlight or UV.
- Do not subject Silkstone products to extremely hot surfaces of water over 60 degrees Celsius
- Do not drop sharp or heavy objects onto Silkstone baths or basins

There are some chemicals and solvents that should never be used on a Silkstone Bath. If unsure please contact Faucet Strommen before use as damages caused by use of unsuitable substances will void warranty. These include:

- Strong Chlorinated Solvents: Chloroform, Chlorobenzine
- Nail polish and paint removers: Methylene Chloride, Acetone, Turpentine, Ethyl Acetate, Furfural.
- Strong Acids
- Ketones, Phenols, Ethers
- Drain cleaners, Toilet Cleaners
- **Salts, Oils, Milks** and other chemical bathwater additives
- Other non-approved liquids or chemicals.

Rejuvenating the Silkstone surface

Extreme damages, scratched or wear may mean that the surface needs to be re-polished to P1500 to achieve a brand new looking surface of silky smoothness. This is a simple process and can be done insitu by a home handyman. This must only be done following Faucet Strommen’s guidelines available on request.

Henge Bath Floor Waste Position (Model 30812)

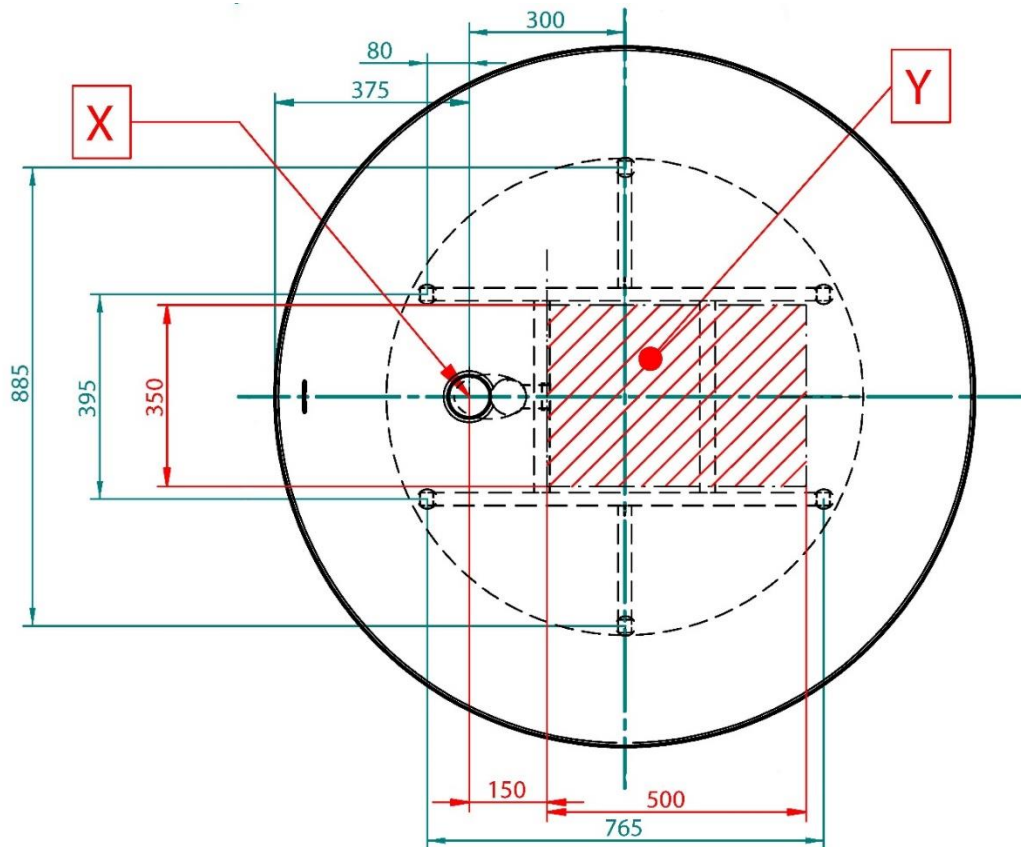

X - Bathtub drain centre
 Y - Floor waste position

Monz Apartment Bath 1500 Floor Waste Position (Model 30807)

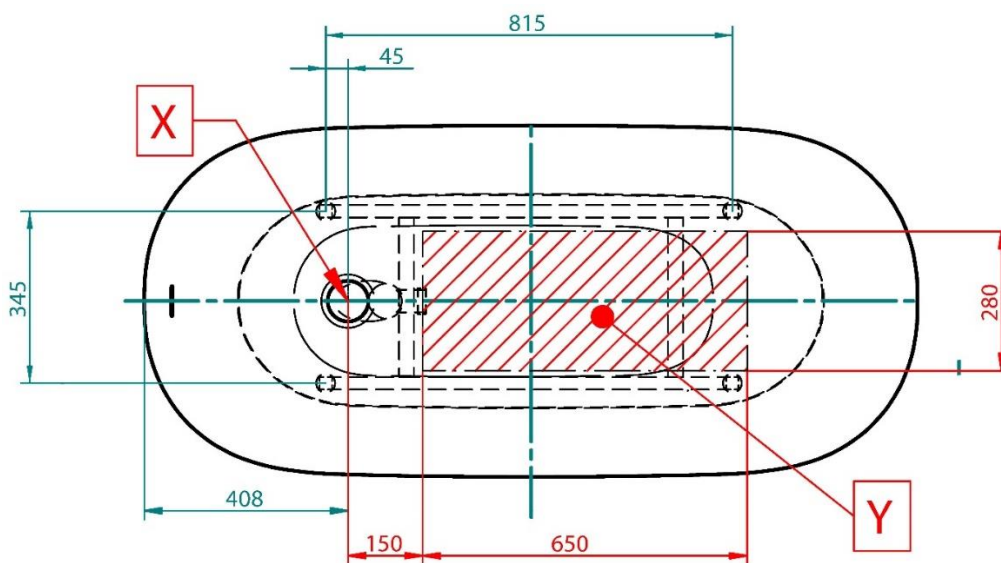

X - Bathtub drain centre
 Y - Floor waste position

Monz Apartment Bath 1400 Floor Waste Position (Model 30809)

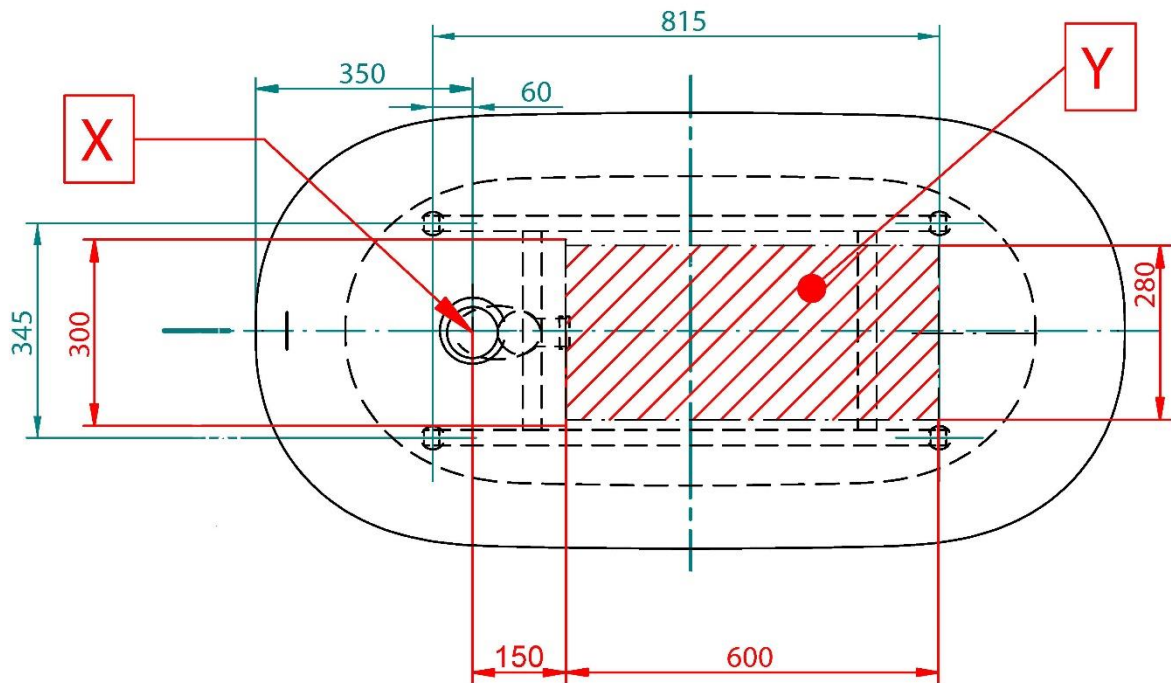

X - Bathtub drain centre
 Y - Floor waste position

Hague Back to Wall Floor Waste Position (Model 30808)

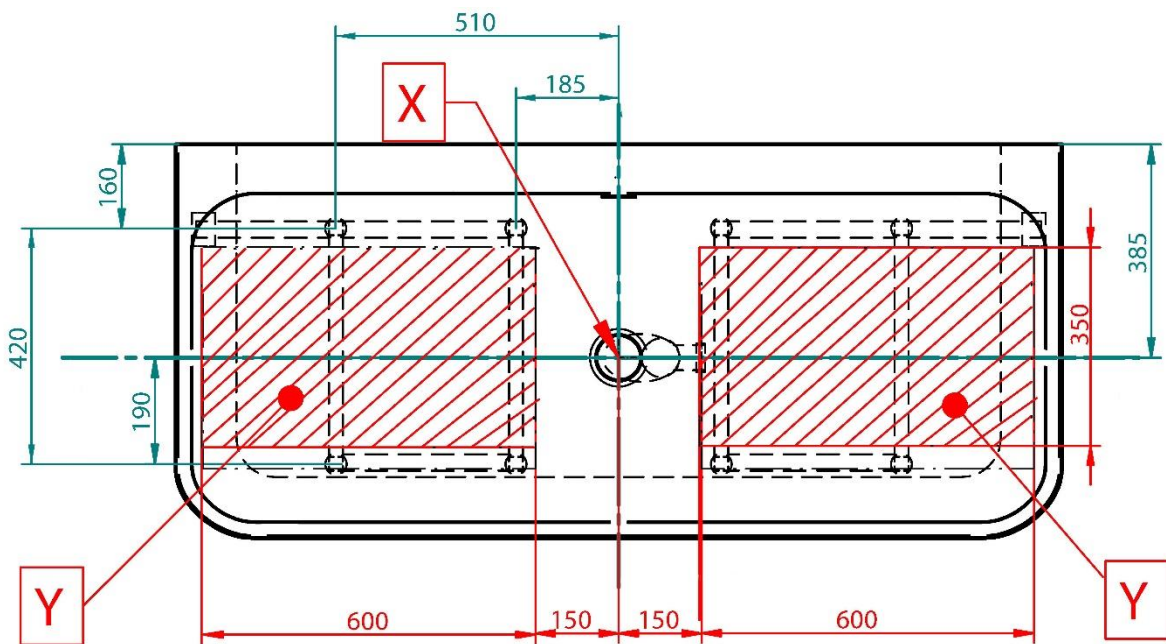

X - Bathtub drain centre
 Y - Floor waste position

Norsk Bath Floor Waste Position (Model 30811)

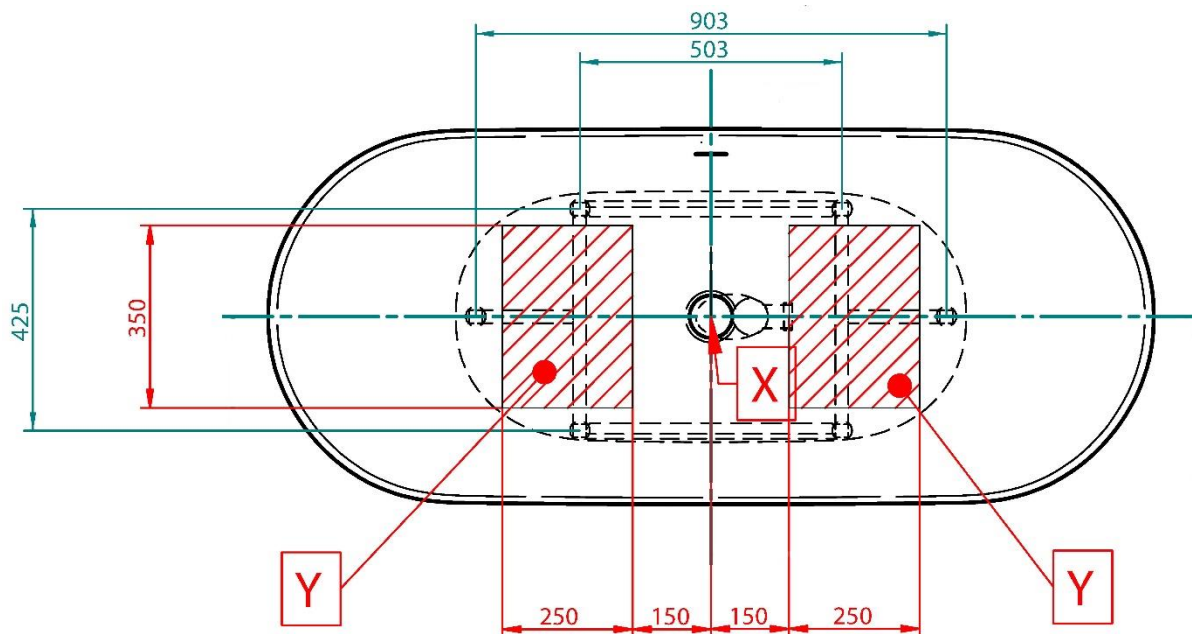

X - Bathtub drain centre
Y - Floor waste position

Calais Bath Floor Waste Position (Model 30804)

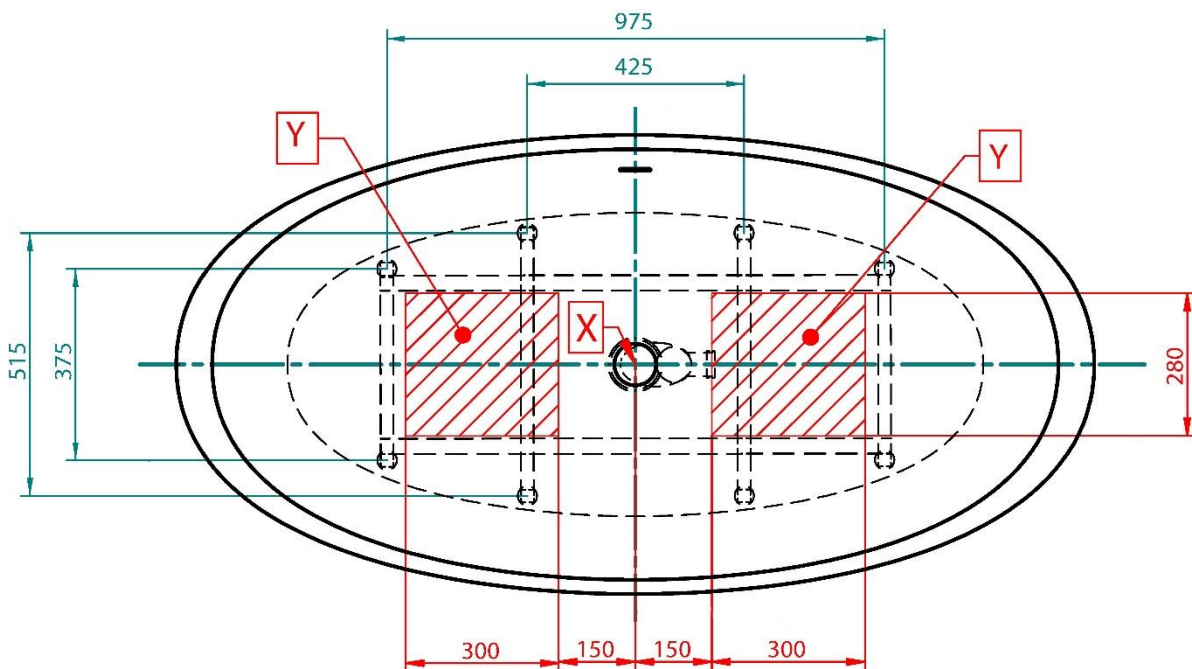

X - Bathtub drain centre
Y - Floor waste position

Fjord Bath Floor Waste Position (Model 30810)

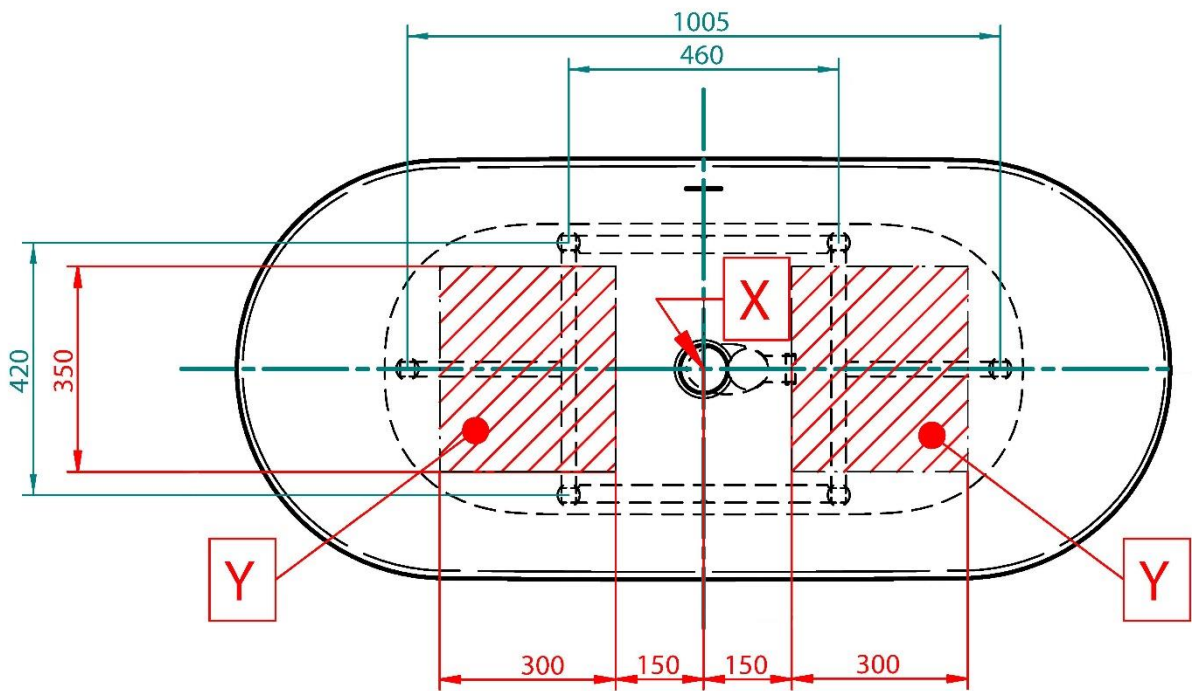

X - Bathtub drain centre
Y - Floor waste position

Elbe Bath Floor Waste Position (Model 30800)

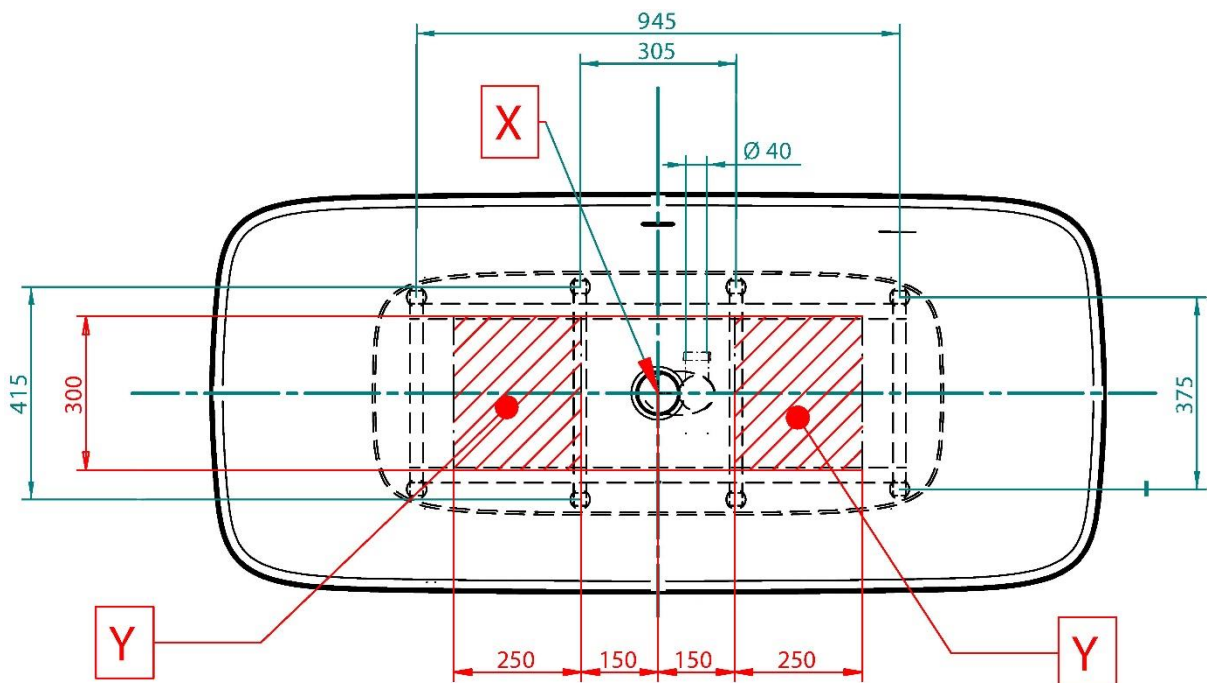

X - Bathtub drain centre
Y - Floor waste position

Danube Bath Floor Waste Position (Model 30806)

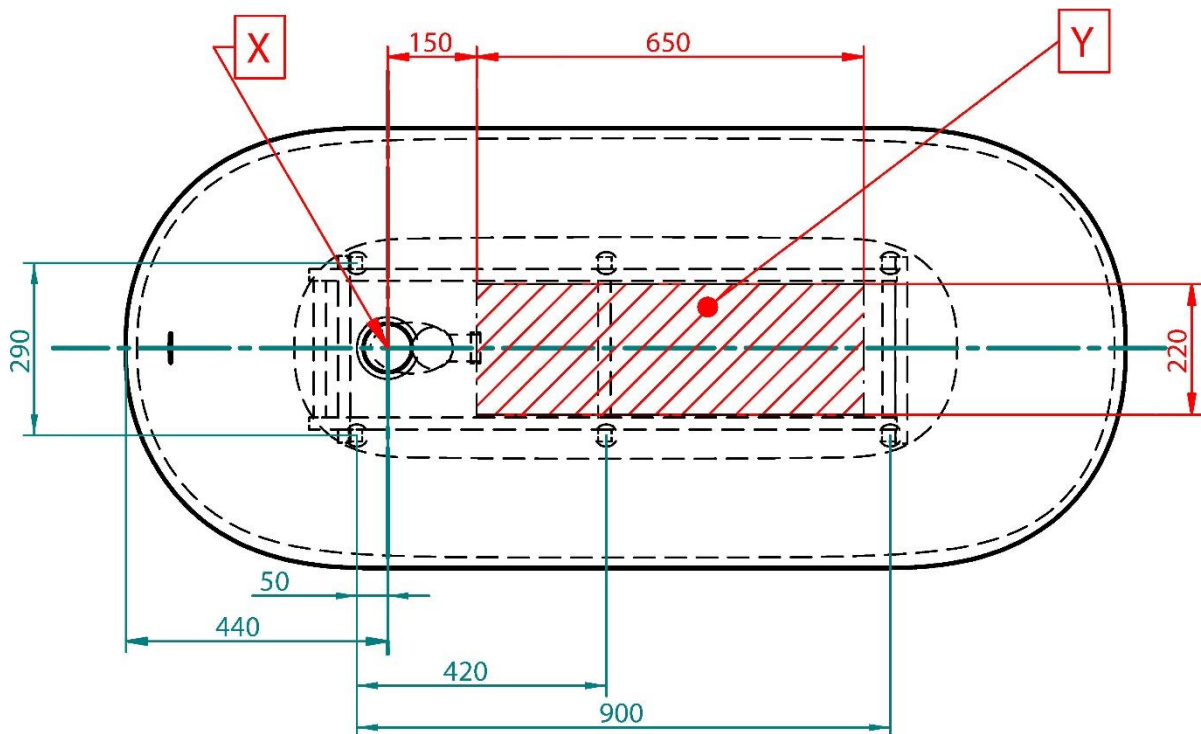

X - Bathtub drain centre
Y - Floor waste position

25
YEARS

25 Years Silkstone Baths & Basins Warranty

Terms & Conditions of Warranty

Faucet Australia Pty Ltd warrants this Engineered Stone bath or basin for 25 years for domestic use from date of purchase.

The liability under this warranty is limited to the repair or replacement of the product. This warranty covers faults in the product construction, material and assembly. Products which are within 25 years from the date of purchase, found upon inspection by an authorized Faucet Strommen representative, to be defective in construction, material or assembly, will be repaired or exchanged with an equivalent product free of charge. Replaced items become Faucet Strommen's property. The labour for replacing or repairing product to which this warranty applies will be supplied by Faucet Strommen for the first 5 years from date of purchase. This warranty does not cover labour for products that are in a position where they cannot be readily removed.

Our goods come with guarantees that cannot be excluded under the Australian Consumer Law. You are entitled to a replacement or refund for a major failure and for compensation for any other reasonably foreseeable loss or damage. You are also entitled to have the goods repaired or replaced if the goods fail to be of acceptable quality and the failure does not amount to a major failure.

The warranty may be invalid if any of the following circumstances exist:

- The product was installed improperly
- The product was used improperly
- The product was exposed to harmful chemicals or acids or extreme environmental conditions.
- The product was used in an application other than domestic
- Proof of purchase is not supplied
- Inadequate maintenance

For Commercial applications including Schools, Hotels, Hospitals, retirement Villages etc these baths are limited to a 2 year warranty including replacement or repair and labour.

Claims must be accompanied with a proof of purchase and made directly to.