

# GENERAL TAPWARE INSTALLATION INSTRUCTIONS

---

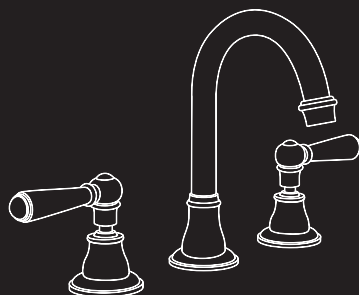
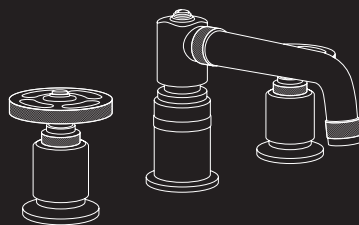

# IMPORTANT INFORMATION

---

## PRE-INSTALLATION NOTES:

- All tapware and showers to be installed by a licensed plumber and to Australian Standards. Fit tempering and pressure reduction valves where required. Flush water lines before fitment to avoid damage to valve.
- Water temperature is not to exceed 50°C as per AS3500
- Water pressure is not to exceed 500kPa as per AS3500
- Pressure difference: Hot - Cold water pressure difference is not to exceed 150kPa. This product is designed to work on high pressure systems only.



**ALL PLUMBING MUST BE TESTED BEFORE CONCEALING / SHEETING OFF AS PER AS3500**

## SHOWERS

---

When installing wall showers ensure that the male connecting threads do not damage the flow controller.

# CERAMIC DISC CARTRIDGE INSTRUCTIONS

---

For use in tap bodies made to Australian Standard AS3500.

1. Note that water inlet temperature not to exceed 50° C and water pressure not to exceed 500 kpa.
2. Important - Flush water lines on new installations to avoid damage to the valves
3. If retro fitting into existing plumbing, the tap seat must be cleaned up with a seating tool to ensure there is a uniform flat surface, square to the tap body.
4. Unscrew and separate cartridge locknut from cartridge body.
5. Remove locknut and install cartridge body with 15mm ring or tube spanner until cartridge comes to a firm stop Do not over-tighten or use multi-grips. Do not tighten cartridge using the spindle.
6. Fit washer over cartridge body and screw down locknut against face of tap body using a 25mm or 1" ring or tube spanner. Do not use multigrips.
7. Fit flange. Fit handle using Hex Allen key supplied.
8. Lever handle taps with ceramic disc cartridge rotate anticlockwise "on" for hot and clockwise "on" for cold. When fitting lever handle cartridges, it is important to first check the position of the lever handle. Lever handles should be fitted so that whilst they point away from each other, they should be parallel. This is done by trial fitting the handles before fitting the locknuts. The cartridge can then be slightly tightened or slightly backed off if needs be to ensure handles are parallel.
9. Seal around bodies to prevent water penetration into wall.
10. Extended cartridges and locknuts available on request at extra cost.

## SEPARATE BEFORE INSTALLING BODY

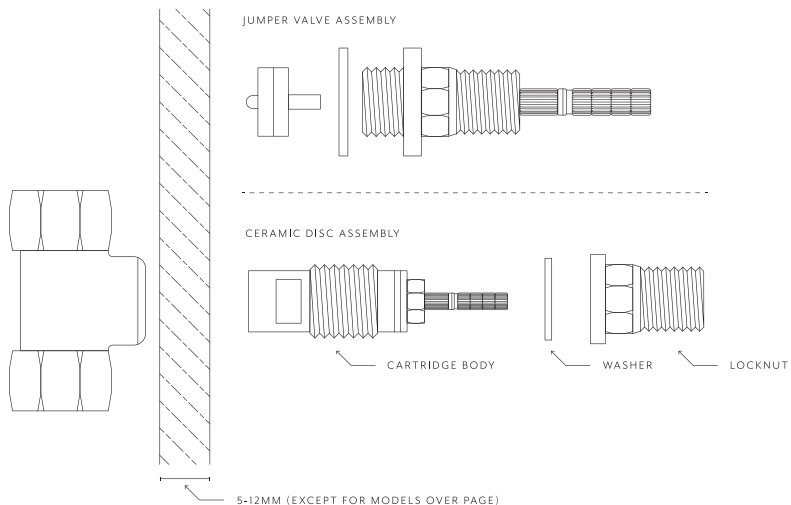

# BASIN SET INSTALLATION INSTRUCTIONS

---

1. Important – Flush water lines on new installations before fitment to avoid damage to valve and blocking of filter or aerator.
2. Measure basin tap hole centres and cut "T" piece to length.
3. Install centre outlet with fibre washer on underside of basin.
4. Remove handles and flanges from taps and fit the spindle assembly to body (see over for installation of ceramic disc cartridge).
5. Connect the "T" piece to bodies - tighten nuts, - push assembly into position connecting "T" piece to centre outlet.
6. Seal around tap bodies with putty or similar.
7. Fit top locknut and washer (where supplied) so that it is flush with top of tap body.  
Note - not all models use top locknuts. Screw down flanges.
8. Fit handles using the Hex Allen key supplied.
9. Tighten all nuts.

Note: If benchtop thickness exceeds 25mm, an extended basin body pack (sold separately) will be required.

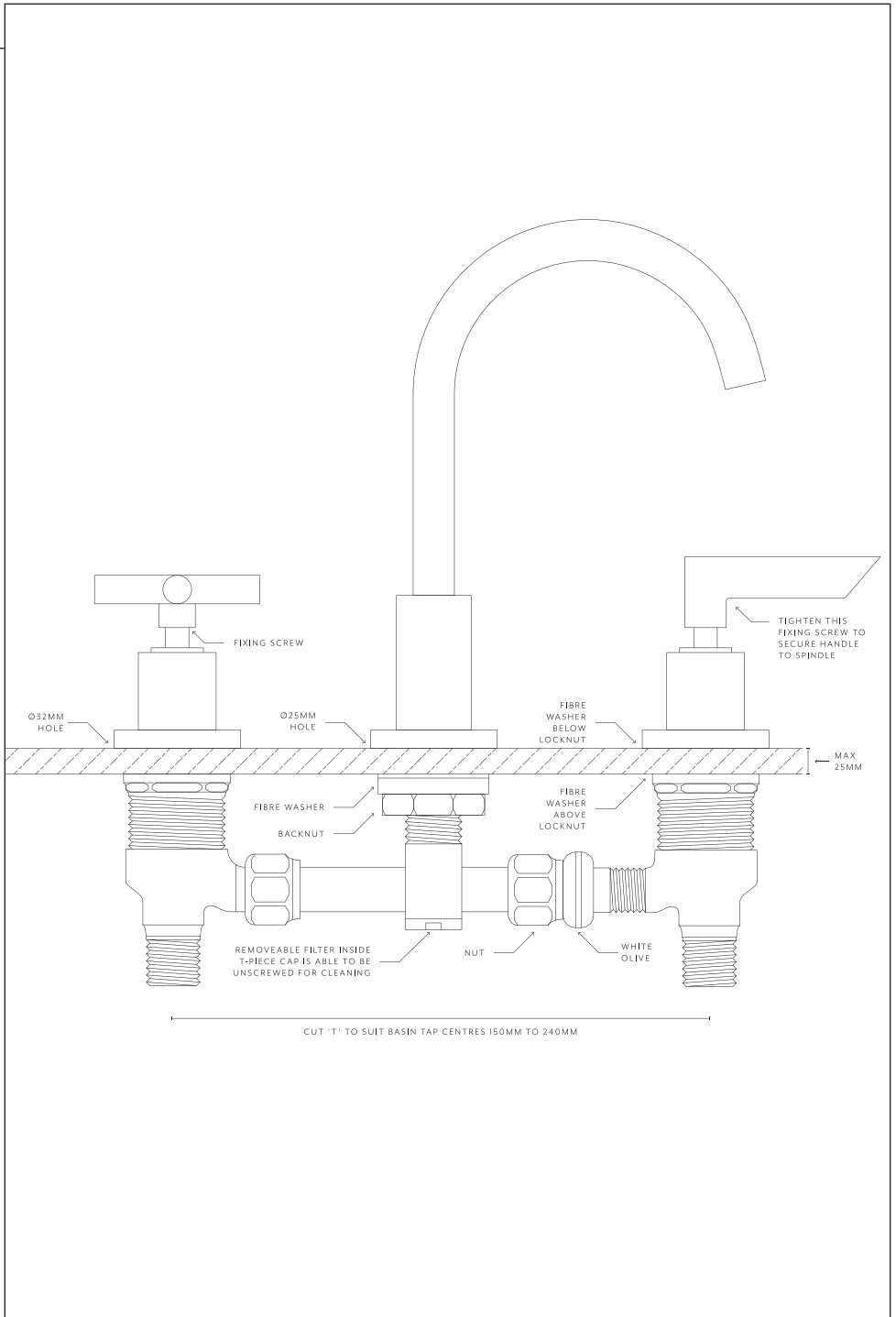

# ADDITIONAL INSTRUCTIONS FOR 1.9206.00, 1.7305.03 & 1.7349.02 WALL SETS

---

## **INSTALLATION DETAILS TO BE READ IN CONJUNCTION WITH CERAMIC DISC INSTRUCTIONS**

For use in tap bodies made to Australian Standard AS3500.

1. Note that water inlet temperature not to exceed 50° C and water pressure not to exceed 500 kpa.
2. Important - Flush water lines on new installations to avoid damage to the valves
3. If retro fitting into existing plumbing, the tap seat must be cleaned up with a seating tool to ensure there is a uniform flat surface, square to the tap body.
4. Unscrew and separate cartridge locknut from cartridge body.
5. Remove locknut and install cartridge body with 15mm ring or tube spanner until cartridge comes to a firm stop Do not over-tighten or use multi-grips. Do not tighten cartridge using the spindle.
6. Fit washer over cartridge body and screw down locknut against face of tap body using a 25mm or 1" ring or tube spanner. Do not use multigrips.
7. Fit flange. Fit handle using Hex Allen key supplied.
8. Lever handle taps with ceramic disc cartridge rotate anticlockwise "on" for hot and clockwise "on" for cold. When fitting lever handle cartridges, it is important to first check the position of the lever handle. Lever handles should be fitted so that whilst they point away from each other, they should be parallel. This is done by trial fitting the handles before fitting the locknuts. The cartridge can then be slightly tightened or slightly backed off if needs be to ensure handles are parallel.
9. Seal around bodies to prevent water penetration into wall.
10. Extended cartridges and locknuts available on request at extra cost.

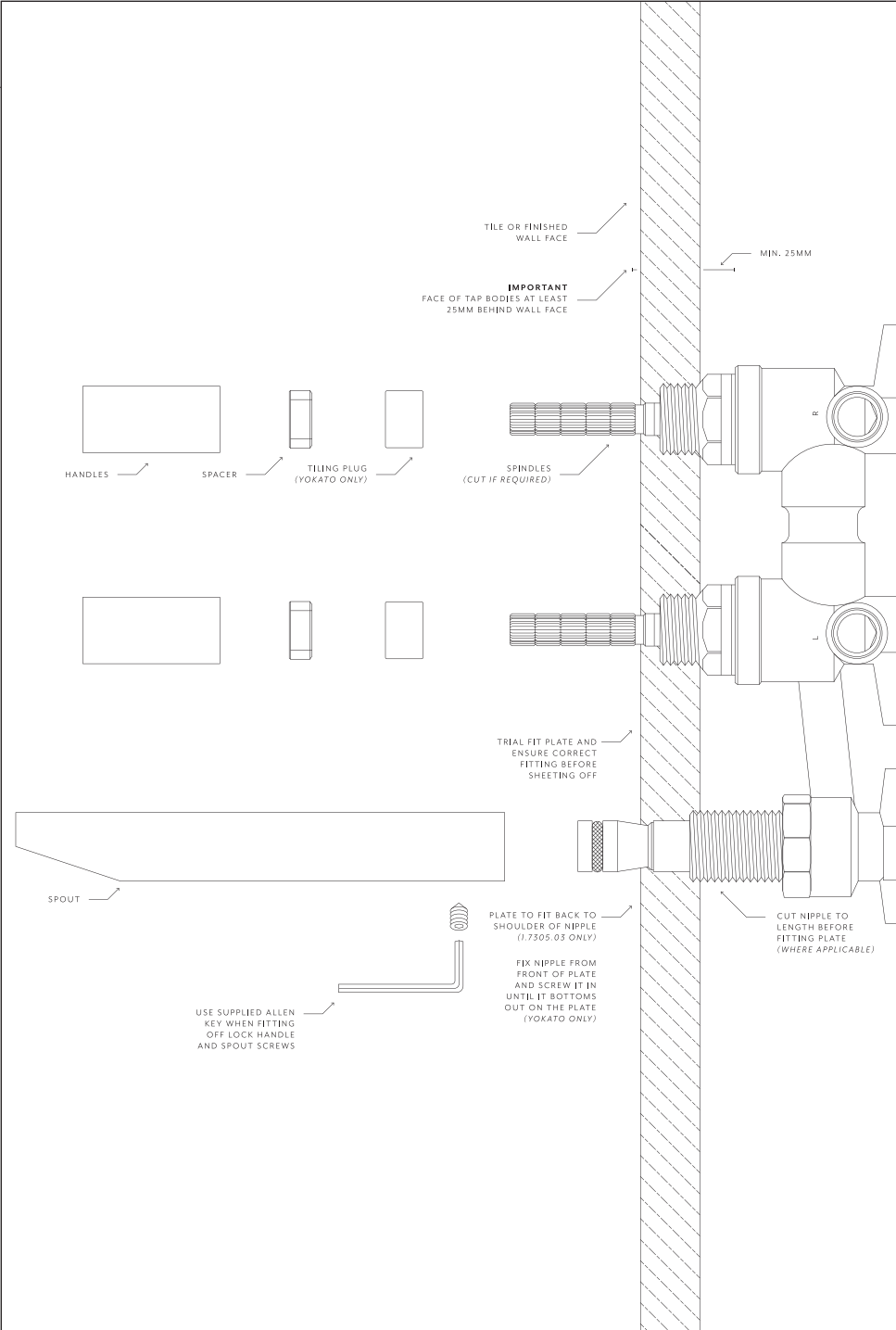

# ADDITIONAL INSTRUCTIONS FOR NANOBAR AND YOKATO

---

## BASIN SET TAPS

Fix handle to spindle by tightening screw with hex key.  
Position fixing screw to rear so it is not seen from the front.

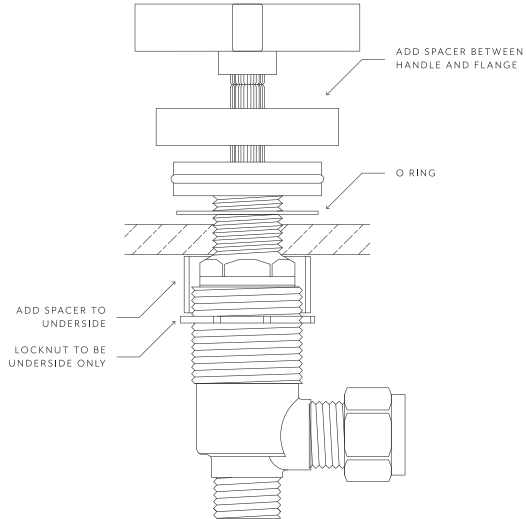

## RECESS TAPS

Important: Front face of inwall body to finished wall face must be min. 16mm to 25mm.

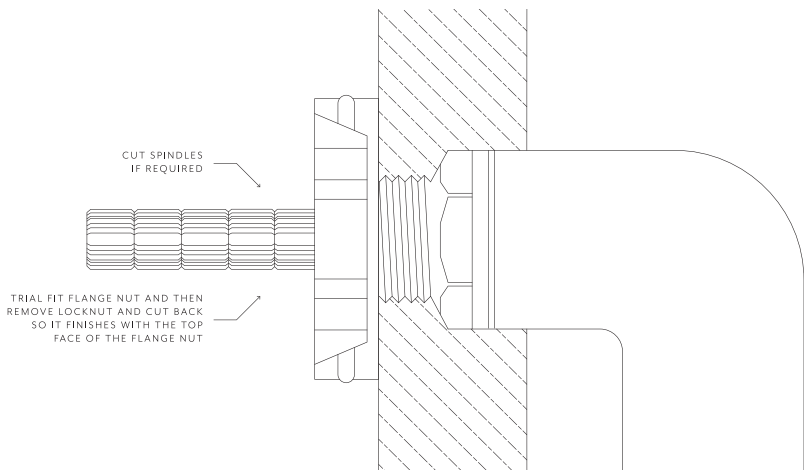



# ADDITIONAL INSTRUCTIONS FOR SQ73, SQ LUX, HALO AND MINIM

## BASIN SET TAPS

Fix handle to spindle by tightening screw with hex key.  
Position fixing screw to rear so it is not seen from the front.

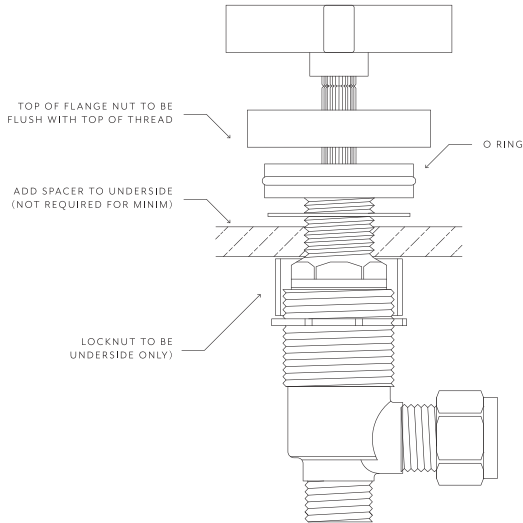

## RECESS TAPS

Important: Front face of inwall body to finished wall face must be min. 16mm to 25mm.

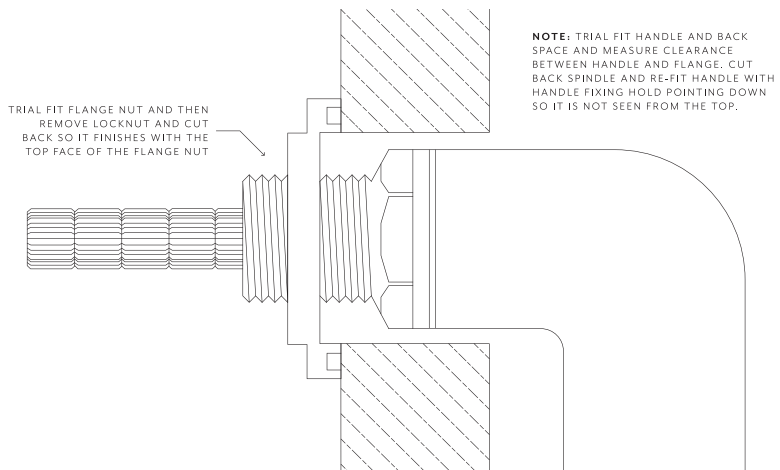

**INSTALLATION DETAILS TO BE READ IN CONJUNCTION WITH CERAMIC DISC INSTRUCTIONS**

# FLOOR MOUNTED 1.7507.30.0.XX

---

1. Install G1/2 thread (not supplied) to finish 65mm above finished floor level.  
Centre and fix fixing flange to floor.  
Fit flange trim and then fit spout base, secure spout base to flange with grub screws.
2. Screw connection hose to G1/2 thread and secure spout to spout base with cap screws, using allen key supplied.
3. If the floor is not level. The adjustment screws in the fixing flange can be adjusted to ensure the spout is vertical.

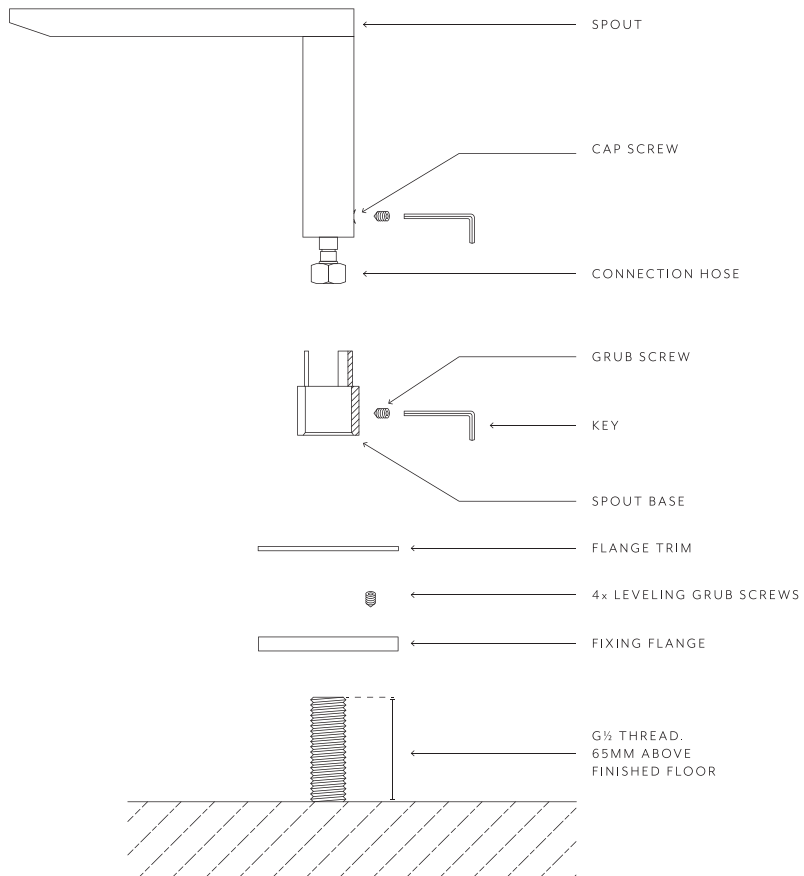

# CITY & MINIM TAPWARE WITH BACKPLATES

---

Important: Front face of inwall body to finished wall face must be min. 12mm to 20mm max.  
Cut spindles and threaded locknut on Minim tapware to suit body depth.

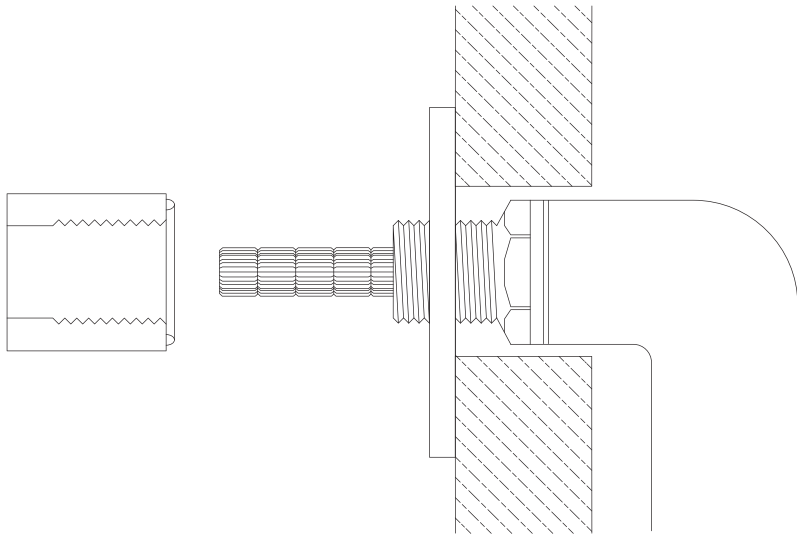

**Vogue** Spas & Bathrooms