

NOTES:

1. ALL DIMENSIONS ARE IN MILLIMETERS.
2. TO ENSURE PROPER FIT A MINIMUM OF 3.0MM CLEARANCE IS REQUIRED, RECCOMENDED CLEARANCE IS 5MM.
3. MUST BE PRINTED ON 8.5X11 PAPER FOR PROPER SCALING, VERIFY SCALE BY CONFIRMING AT LEAST TWO DIMENSIONS.
4. CUT ALONG "CUT LINE" DIMENSIONS FOR 3MM CLEARANCE TO WHEEL

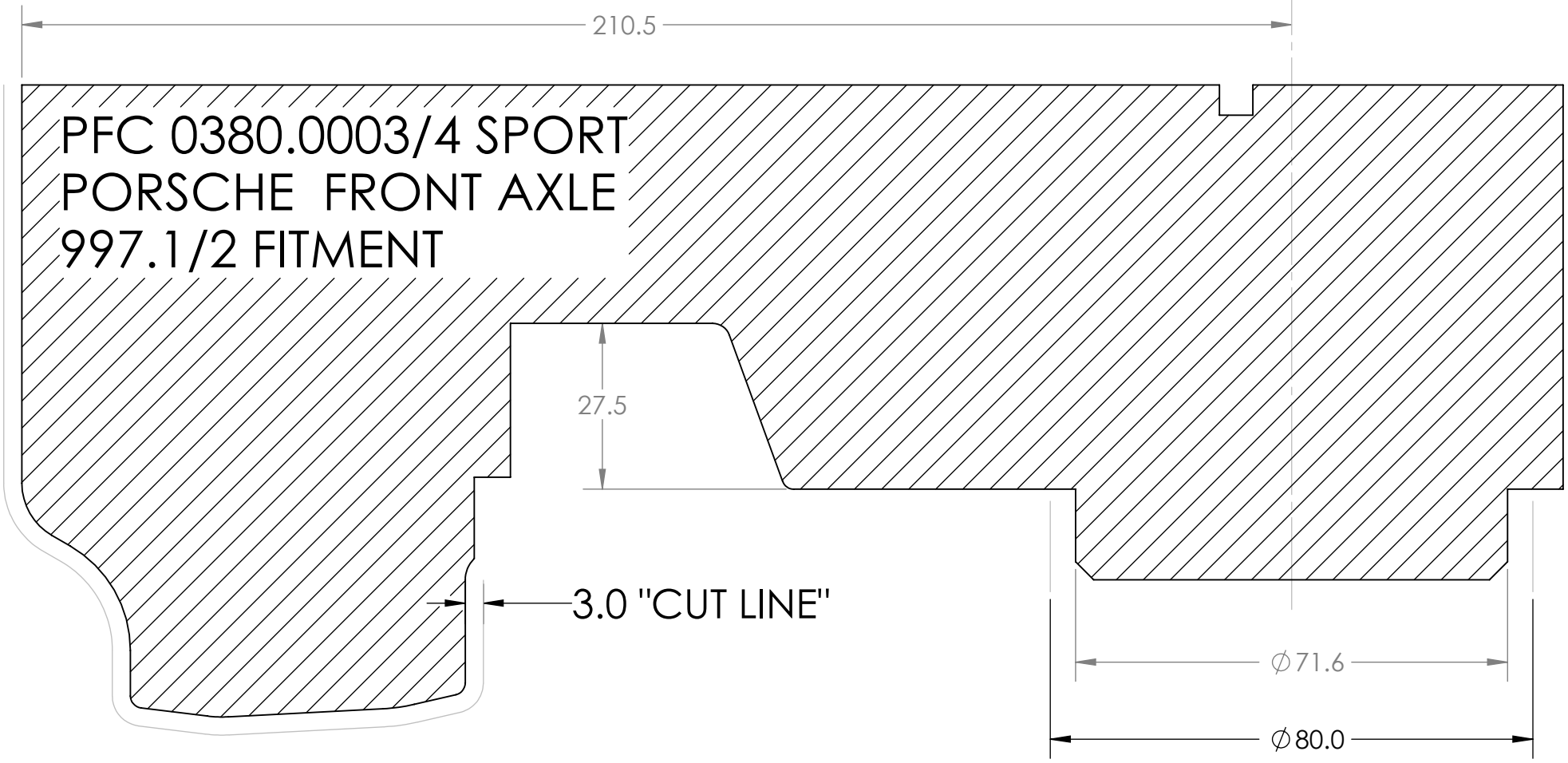

PFC PART NO.	FILE NAME	CREATED DATE	DRAWN BY	PERFORMANCE FRICTION CORP 83 CARBON METALLIC HIGHWAY CLOVER, SC 29710
NA	ZR95 PROFILES - PORSCHE	01/07/22	J. BORNER	



NOTES:

1. ALL DIMENSIONS ARE IN MILLIMETERS.
2. TO ENSURE PROPER FIT A MINIMUM OF 3.0MM CLEARANCE IS REQUIRED, RECCOMENDED CLEARANCE IS 5MM.
3. MUST BE PRINTED ON 8.5X11 PAPER FOR PROPER SCALING, VERIFY SCALE BY CONFIRMING AT LEAST TWO DIMENSIONS.
4. CUT ALONG "CUT LINE" DIMENSIONS FOR 3MM CLEARANCE TO WHEEL



PFC PART NO.	FILE NAME	CREATED DATE	DRAWN BY	PERFORMANCE FRICTION CORP 83 CARBON METALLIC HIGHWAY CLOVER, SC 29710
NA	ZR95 PROFILES - PORSCHE	01/07/22	J. BORNER	

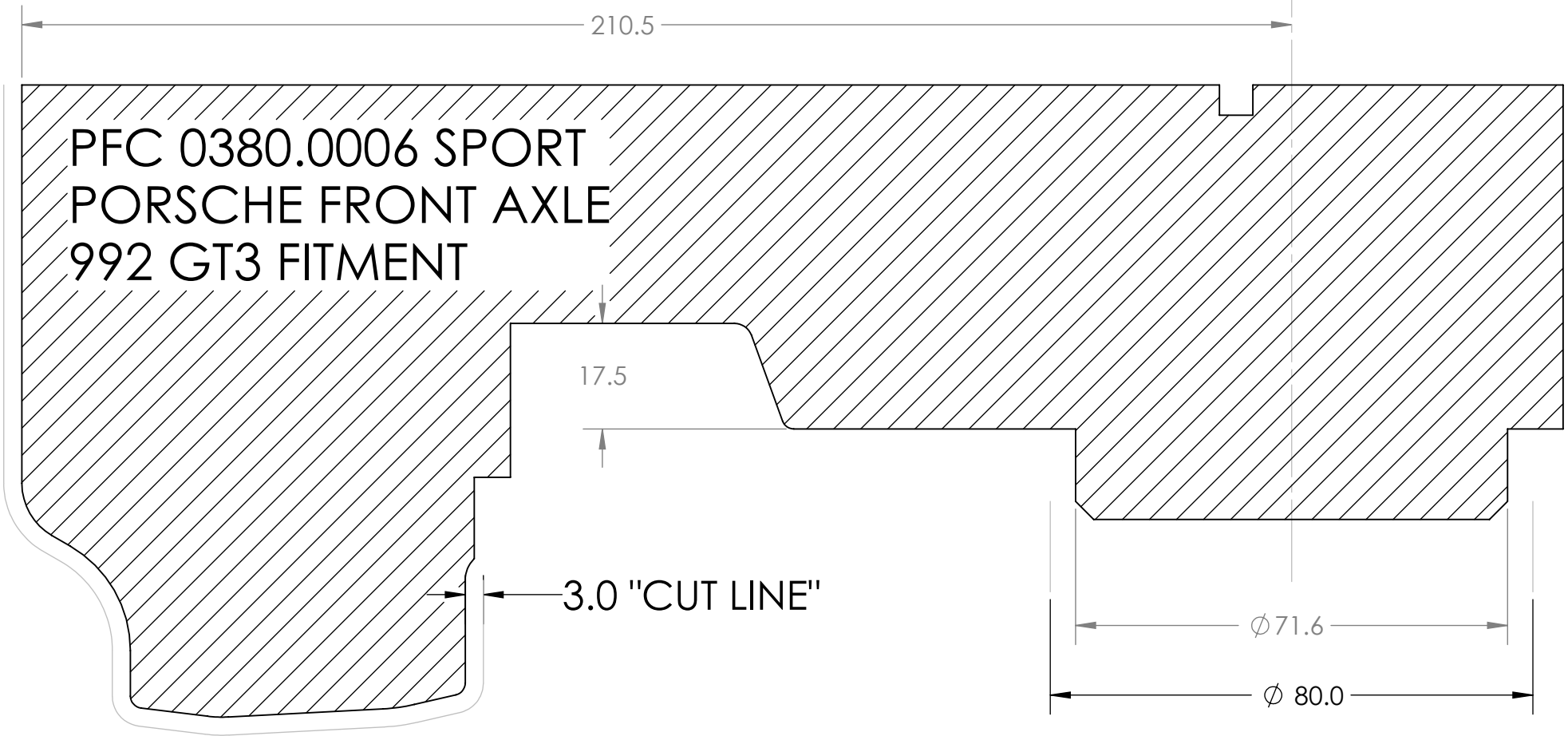

NOTES:

1. ALL DIMENSIONS ARE IN MILLIMETERS.
2. TO ENSURE PROPER FIT A MINIMUM OF 3.0MM CLEARANCE IS REQUIRED, RECCOMENDED CLEARANCE IS 5MM.
3. MUST BE PRINTED ON 8.5X11 PAPER FOR PROPER SCALING, VERIFY SCALE BY CONFIRMING AT LEAST TWO DIMENSIONS.
4. CUT ALONG "CUT LINE" DIMENSIONS FOR 3MM CLEARANCE TO WHEEL



PFC PART NO.	FILE NAME	CREATED DATE	DRAWN BY	PERFORMANCE FRICTION CORP 83 CARBON METALLIC HIGHWAY CLOVER, SC 29710
NA	ZR95 PROFILES - PORSCHE	01/07/22	J. BORNER	

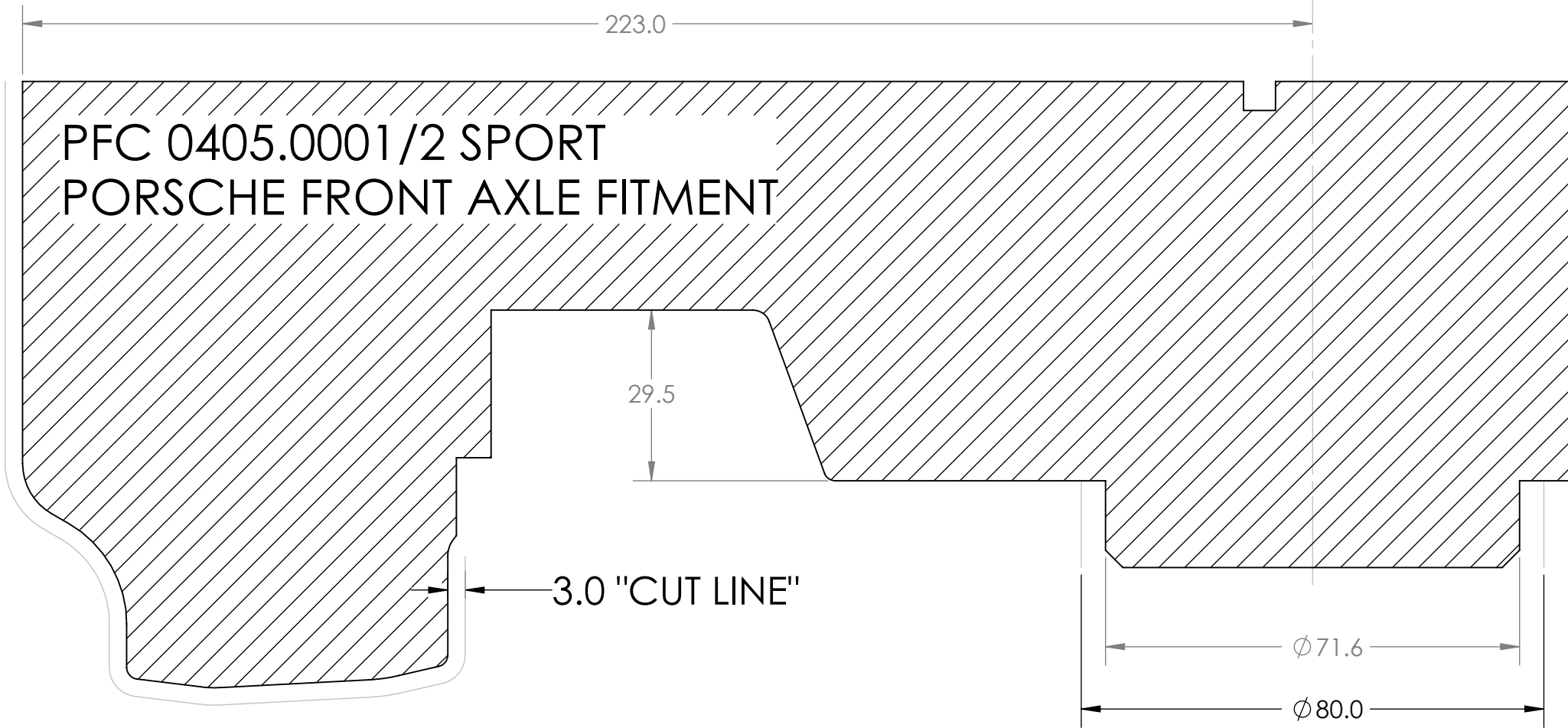

NOTES:

1. ALL DIMENSIONS ARE IN MILLIMETERS.
2. TO ENSURE PROPER FIT A MINIMUM OF 3.0MM CLEARANCE IS REQUIRED, RECCOMENDED CLEARANCE IS 5MM.
3. MUST BE PRINTED ON 8.5X11 PAPER FOR PROPER SCALING, VERIFY SCALE BY CONFIRMING AT LEAST TWO DIMENSIONS.
4. CUT ALONG "CUT LINE" DIMENSIONS FOR 3MM CLEARANCE TO WHEEL



PFC PART NO.	FILE NAME	CREATED DATE	DRAWN BY	PERFORMANCE FRICTION CORP 83 CARBON METALLIC HIGHWAY CLOVER, SC 29710
NA	ZR95 PROFILES - PORSCHE	01/07/22	J. BORNER	

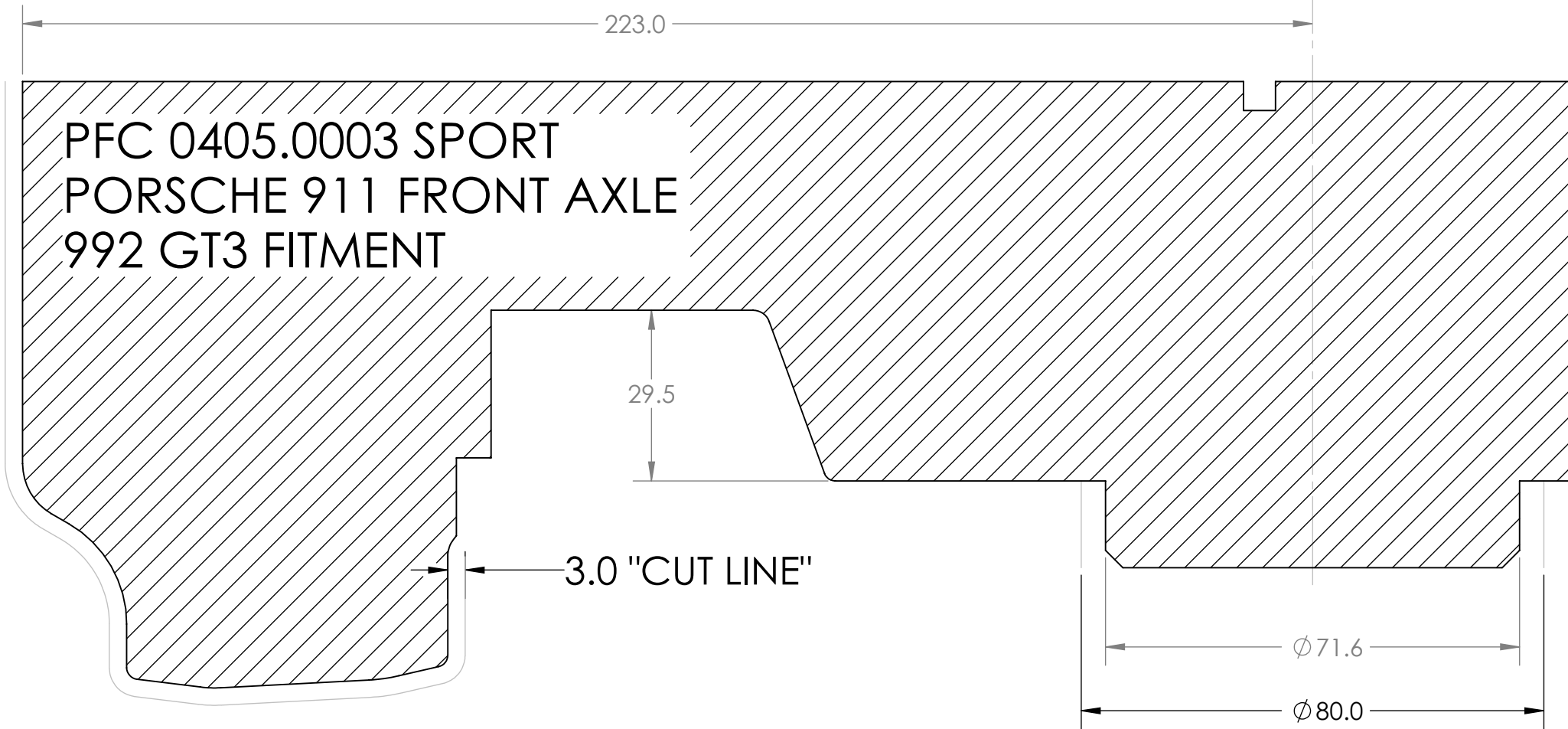

NOTES:

1. ALL DIMENSIONS ARE IN MILLIMETERS.
2. TO ENSURE PROPER FIT A MINIMUM OF 3.0MM CLEARANCE IS REQUIRED, RECCOMENDED CLEARANCE IS 5MM.
3. MUST BE PRINTED ON 8.5X11 PAPER FOR PROPER SCALING, VERIFY SCALE BY CONFIRMING AT LEAST TWO DIMENSIONS.
4. CUT ALONG "CUT LINE" DIMENSIONS FOR 3MM CLEARANCE TO WHEEL



PFC PART NO.	FILE NAME	CREATED DATE	DRAWN BY	PERFORMANCE FRICTION CORP 83 CARBON METALLIC HIGHWAY CLOVER, SC 29710
NA	ZR95 PROFILES - PORSCHE	01/07/22	J. BORNER	

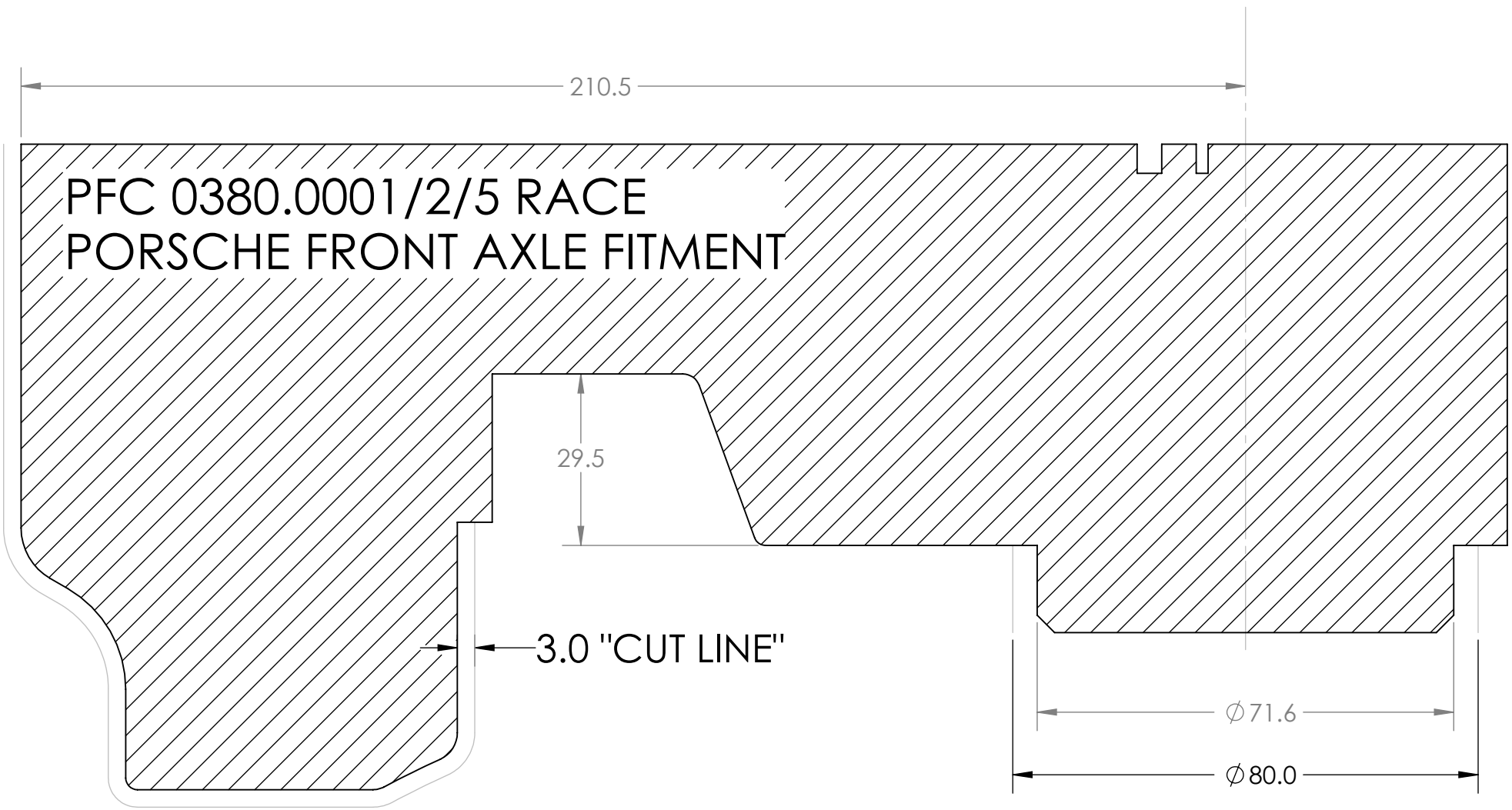

NOTES:

1. ALL DIMENSIONS ARE IN MILLIMETERS.
2. TO ENSURE PROPER FIT A MINIMUM OF 3.0MM CLEARANCE IS REQUIRED, RECCOMENDED CLEARANCE IS 5MM.
3. MUST BE PRINTED ON 8.5X11 PAPER FOR PROPER SCALING, VERIFY SCALE BY CONFIRMING AT LEAST TWO DIMENSIONS.
4. CUT ALONG "CUT LINE" DIMENSIONS FOR 3MM CLEARANCE TO WHEEL



PFC PART NO.	FILE NAME	CREATED DATE	DRAWN BY	PERFORMANCE FRICTION CORP 83 CARBON METALLIC HIGHWAY CLOVER, SC 29710
NA	ZR95 PROFILES - PORSCHE	01/07/22	J. BORNER	

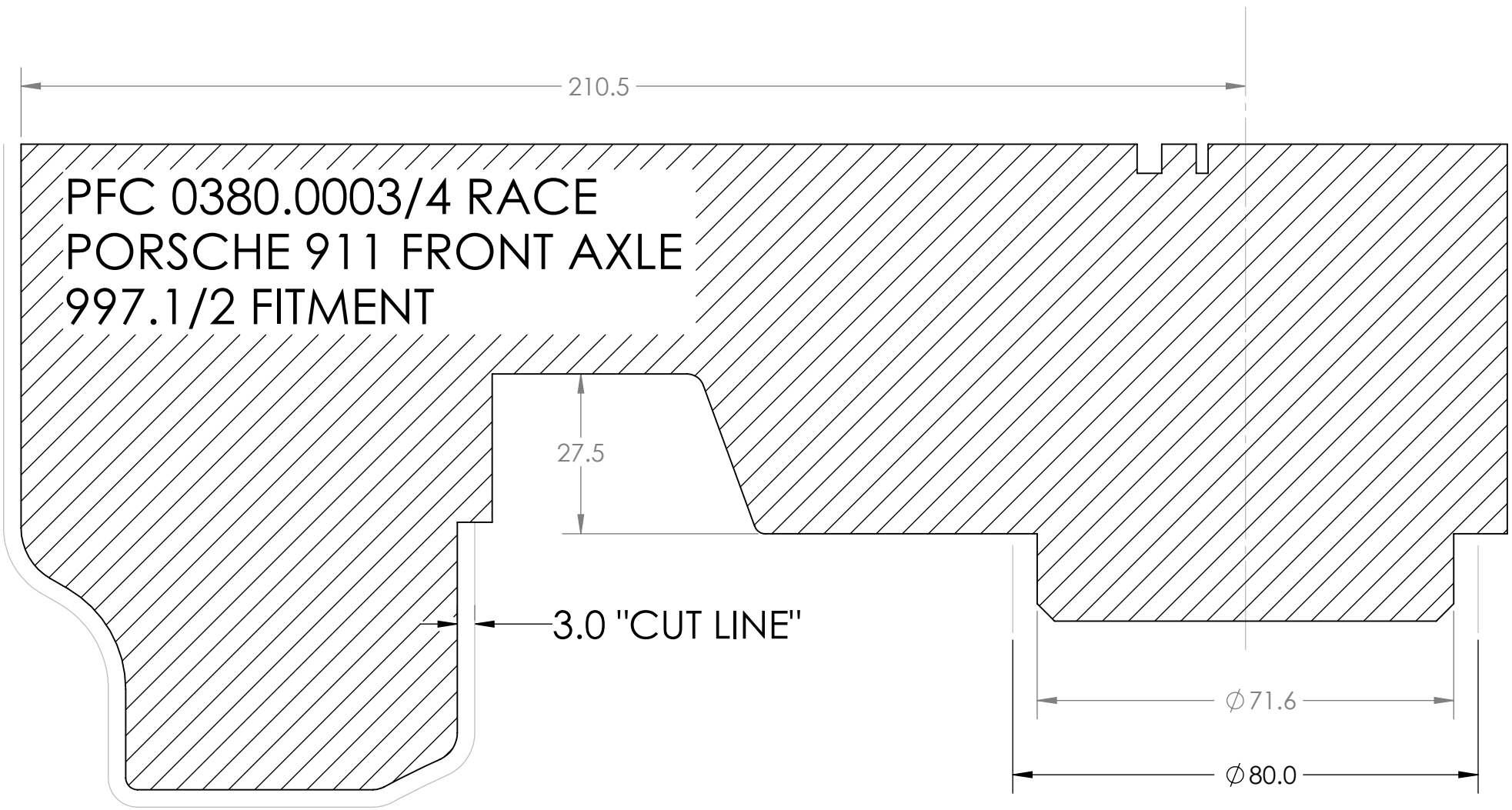

NOTES:

1. ALL DIMENSIONS ARE IN MILLIMETERS.
2. TO ENSURE PROPER FIT A MINIMUM OF 3.0MM CLEARANCE IS REQUIRED, RECCOMENDED CLEARANCE IS 5MM.
3. MUST BE PRINTED ON 8.5X11 PAPER FOR PROPER SCALING, VERIFY SCALE BY CONFIRMING AT LEAST TWO DIMENSIONS.
4. CUT ALONG "CUT LINE" DIMENSIONS FOR 3MM CLEARANCE TO WHEEL



PFC PART NO.	FILE NAME	CREATED DATE	DRAWN BY	PERFORMANCE FRICTION CORP 83 CARBON METALLIC HIGHWAY CLOVER, SC 29710
NA	ZR95 PROFILES - PORSCHE	01/07/22	J. BORNER	

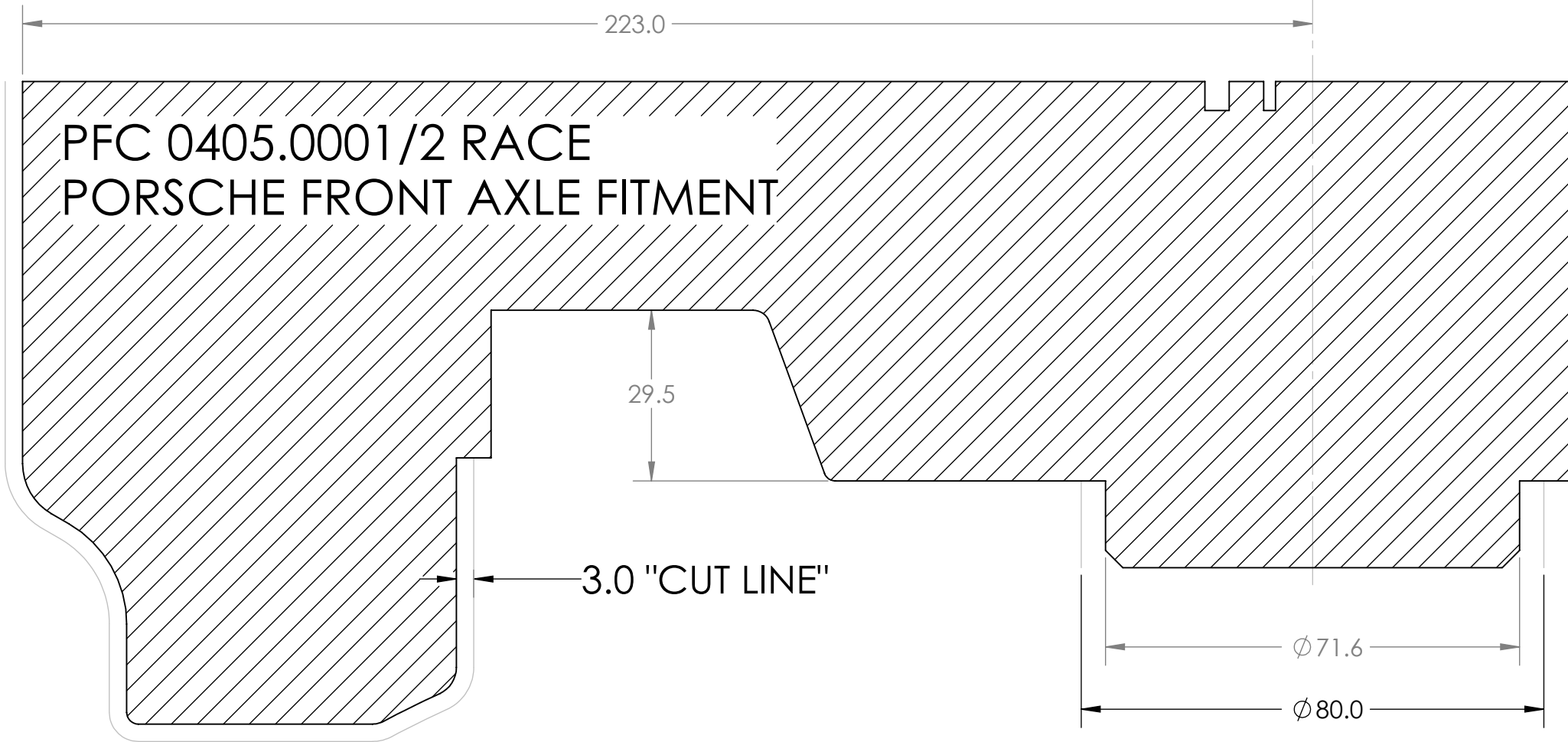

NOTES:

1. ALL DIMENSIONS ARE IN MILLIMETERS.
2. TO ENSURE PROPER FIT A MINIMUM OF 3.0MM CLEARANCE IS REQUIRED, RECCOMENDED CLEARANCE IS 5MM.
3. MUST BE PRINTED ON 8.5X11 PAPER FOR PROPER SCALING, VERIFY SCALE BY CONFIRMING AT LEAST TWO DIMENSIONS.
4. CUT ALONG "CUT LINE" DIMENSIONS FOR 3MM CLEARANCE TO WHEEL



PFC PART NO.	FILE NAME	CREATED DATE	DRAWN BY	PERFORMANCE FRICTION CORP 83 CARBON METALLIC HIGHWAY CLOVER, SC 29710
NA	ZR95 PROFILES - PORSCHE	01/07/22	J. BORNER	