



Quick Installation Guide

AX1800 Wi-Fi 6 Smart WiFi Router

RSD0616

In the box

Wireless router x 1
Power adapter x 1
Ethernet cable x 1
Quick Installation Guide x 1

Quick Installation Guide

Technical Support:
Phone: 1-833-816-6558
(EST 10:00-21:00 from Monday to Friday)
Email: techsupport@rockspace.cc
Website: rockspaceworld.com

I. Connect your router

Hello, welcome to the rock space.

Note:

If this is the first time you are using a router or you are not very proficient in router settings, please skip the Step 1 and start from Step 2.

If you are very proficient in router settings and know what is the PPPoE user name and password, you can refer to step 1 to copy them from your original router to AX1800 WiFi router. It will save you some time.

Step 1: Import your PPPoE user name and password from your original router.

1. Power on your original and new routers.
2. Connect the WAN port of the original router to a LAN port of the new router using an Ethernet cable.
3. When the WAN and LAN LED indicators of the new router turn solid on for 3 seconds after blinking fast, the PPPoE user name and password are imported to your new router successfully.

Quick Setup

The screenshot shows a progress bar with four steps: 1. Time Zone Setting, 2. WAN Connection Setting (highlighted), 3. Wireless Setting, and 4. Finish. Below the progress bar, the 'PPPoE' option is selected. The instruction reads: 'Please enter your PPPoE username and password.' The 'Username' field contains '0307193028111' and the 'Password' field contains 'gd12345'. At the bottom, there are 'Back' and 'Next' buttons.

Note: If the PPPoE user name and password are imported to your new router successfully, this router will auto-fill the ISP User Name and ISP Password when you select PPPoE connection type.

4. Remove the original router.

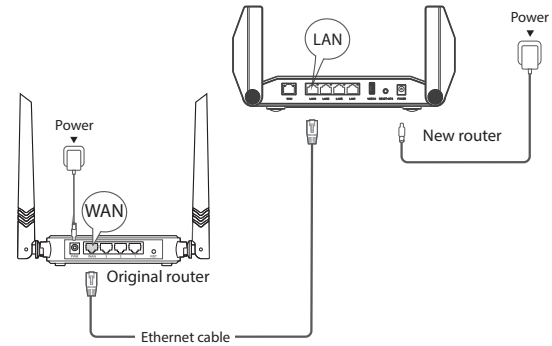

Step 2: Connect your new router to the internet.

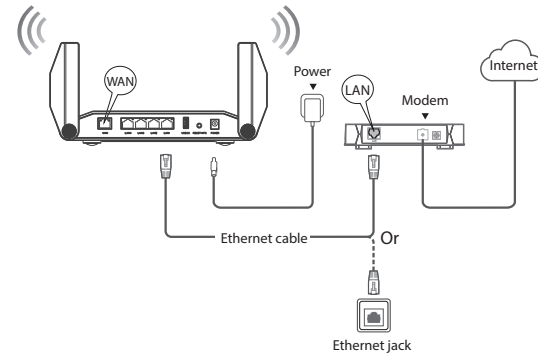

1. Power on the new router.
2. Connect the WAN port of the new router to the LAN port of your modem or the Ethernet jack using an Ethernet cable. The WAN LED indicator lights on.

II. Connect your devices to the new router

Method 1: Connect your WiFi-enabled device (such as a smart phone) to the new router's WiFi network using the SSID (WiFi name) labeled on the bottom of the router. There is no WiFi password by default.

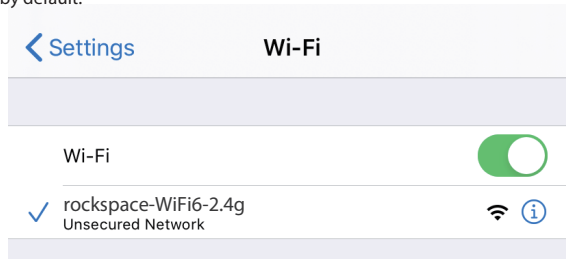

Method 2: Connect your wired device (such as a computer) to a LAN port of the router using an Ethernet cable. The LAN LED indicator lights up.

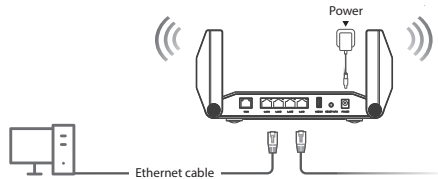

III. Set up the new router for internet access

Step 1: Enter the IP address.

After the connection with your client device is established, the setup page will automatically pop up.

If the setup page doesn't pop up automatically, open your browser on your device and enter 192.168.1.1 in the address bar and press "Start" on the start page.

In the Password field, type the user name(admin)and password(admin)to log into the management interface.

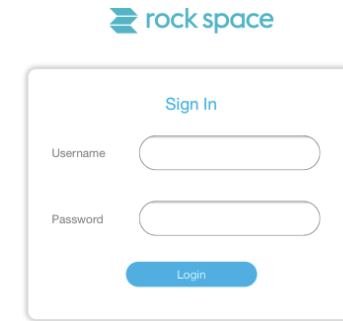

Note: Both the user name and password is "admin". The password you entered in this step is NOT the password for your extended network, it is the password for the extender's management interface. If you cannot log in to the web UI of the router, refer to Q1 in FAQ.

Step 2: Set up the time zone.

Please select your region and time zone. Then click "Next".

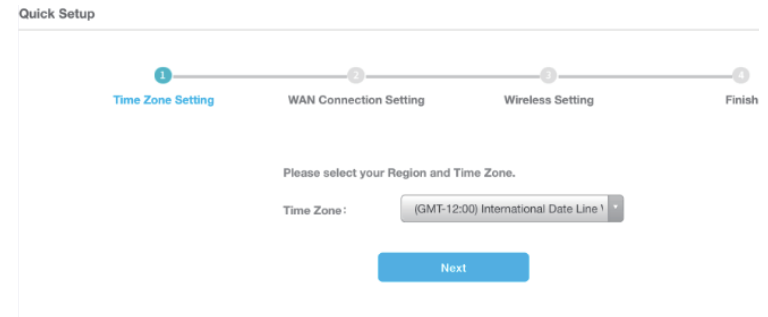

Step 3: Select your Connection Type.

The router supports three connection types: PPPoE, Dynamic IP Address and Static IP Address. And the router will detect your internet connection type automatically. Set required parameters and click "Next".

1 Time Zone Setting 2 WAN Connection Setting 3 Wireless Setting 4 Finish

Dynamic IP
- For Cable/DSL/Broadband connection which makes your computer immediately online without ant setting or signing-in.

Static IP
- You are provided with specified IP parameters by your ISP.

PPPoE
- Usually for ADSL Modem and you are provided with a PPPoE username and password by your ISP.

Back Next

Note: If your internet connection type is Dynamic IP, tap "Next".

Quick Setup

1 Time Zone Setting 2 WAN Connection Setting 3 Wireless Setting 4 Finish

Static IP

Please select your Region and Time Zone.

IP Address

Subnet Mask

Default Gateway

Primary DNS

Secondary DNS

Back Next

Note: PPPoE is used for illustration here. If you migrated your PPPoE user name and password from your original router, this router auto-fills the ISP User Name and ISP Password. Otherwise, you should enter your PPPoE user name and password and tap "Next".

Quick Setup

1 Time Zone Setting 2 WAN Connection Setting 3 Wireless Setting 4 Finish

PPPoE

Please enter your PPPoE username and password.

Username :

Password :

Back Next

Note: If your internet connection type is Static IP, enter your IP address and other information your ISP provides, and tap "Next".

Step 4: The wireless setting.

Customize your Wi-Fi name (SSID) and Wi-Fi password. You can also hide the SSID, and click "Next".

1 Time Zone Setting 2 WAN Connection Setting 3 Wireless Setting 4 Finish

You can change the wireless network name and password.

2.4G Network

Network Name Hide SSID

Password

5G Network

Network Name Hide SSID

Password

Back Next

Note: If you have hidden one or two network name, you should follow the instructions below after finishing the setup.

Turn on the smart phone. Then click "Settings>WLAN>Add Network". And fill in the network name you have hidden. Such as "rockspace-WiFi6-2.4g". Click "Connect", and enter the new password. You will connect the network successfully.

Step 5: Finish setting.

Confirm your network name and password and click "Next".

1 Time Zone Setting 2 WAN Connection Setting 3 Wireless Setting 4 Finish

Check your setup information, if correct, please click Save.

2.4G Network

Network Name *rockspace wifi6 2.4g*

Password *12345678*

5G Network

Network Name *rockspace WiFi6 5g*

Password *12345678*

Back Next

Note: After this setting, the router will reboot again. Go to your Wi-Fi network list and find the SSID named by yourself. The WiFi-enabled devices can connect to the AX1800 router by entering the new password. And the wired devices connected to the router can access the internet directly now. If you want to modify the settings, please log in the management page (IP address is 192.168.1.1) again after completing the initial settings.

Step 6: Customize more functions.

Please log in to the management page again. The IP address is 192.168.1.1. You can customize the functions you need on this page.

Network Map

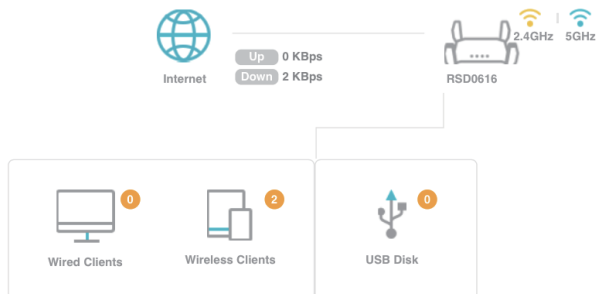

Internet

Internet Status :	Connected	System Runtime :	00:20:32
Connection Type :	DHCP	System Time :	2020-08-18 18:08:49
IP Address :	172.16.12.81	System Time Zone :	(GMT-12:00) International Date Line West
Subnet Mask :	255.255.255.0		
Gateway :	172.16.12.1		
DNS1 :	202.96.134.133		
DNS2 :	0.0.0.0		

Note: Any questions, you can refer to FAQ firstly.

Dual Band Setting

Please log in to the management page. The IP address is 192.168.1.1.

1. Click "Wireless". You could customize your private network name and password here.

Wireless Setting

2.4GHz Network

Network Name :

Hide SSID

Password :

5GHz Network

Network Name :

Hide SSID

Password :

Save

2. Select "Hide SSID". You could hide the 2.4GHZ Network or the 5GHZ Network and click "Save".

Wireless Setting

2.4GHz Network

Network Name : Hide SSID

Password : ✓

5GHz Network

Network Name : Hide SSID

Password :

Save

Note: The router will reboot after changing the network name and password, please reconnect by applying the new network name (SSID) and password.

3. Turn on the smart phone. Then click "Settings>WLAN>Add Network". And fill in the network name you have hidden. Such as "rockspace-WiFi6-2.4g". Click "Connect", and enter the new password. You will connect the network successfully.

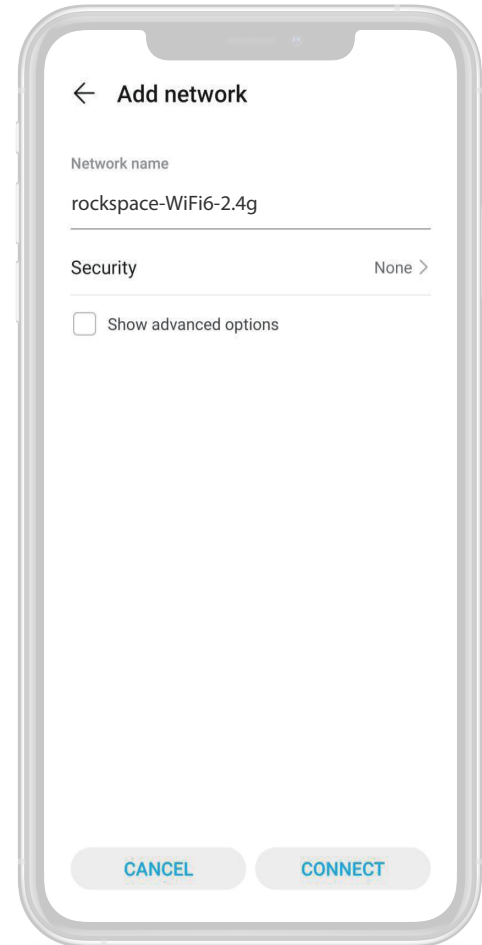

Parental Control

Please log in to the management page. The IP address is 192.168.1.1.

1. Click "Advanced Settings> Network Control>Parental Control". In this interface, you can add the device that you want to set a parental control.

Parental Control <Back

Parental Control + Add

Device Name	MAC Address	Edit
-------------	-------------	------

2. Turn on "Parental Control" and click "Add". You could enter the device name, MAC Address, access time restriction and choose the repeat mode.

Note: Click the "Network Map>Wireless Clients", and you will find all the device name and MAC Address. After this setting, the router will reboot again. Please reconnect to the router.

Access Control

Please log in to the management page. The IP address is 192.168.1.1.

1. Click "Advanced Settings> Network Control>Access Control". In this interface, you can add the device that you want to set an access control.

Access Control <Back

Access Control + Add

Mode: Blacklist Whitelist

ID	Device Name	MAC Address	Edit
----	-------------	-------------	------

2. Turn on "Access Control", choose "Blacklist" or "Whitelist" and click "Add". You could enter the device name and MAC Address.

Note: Click the "Network Map>Wireless Clients", and you will find all the device name and MAC Address. After this setting, the router will reboot again. Please reconnect to the router.

Guest Network

Please log in to the management page. The IP address is 192.168.1.1.

1. Click "Advanced Settings> Guest Network". In this interface, you can set your guest network.

Guest Network

2.4GHz Guest Network

Network Name(SSID) :

Password :

5GHz Guest Network

Network Name(SSID) :

Password :

Save

2. You can turn on one of the "2.4GHz Guest Network" and "5GHz Guest Network" or both of them. Customize your guest network name and password and click "Save".

Guest Network

2.4GHz Guest Network

Network Name(SSID) :

Password :

5GHz Guest Network

Network Name(SSID) :

Password :

Save

Note: After this setting, the router will reboot again. Please reconnect to the router.

More features

In addition to some of the settings described above, there are more functions. Including Virtual Server, DHCP, UPnP, DMZ, DNS and Firewall Security.

Note: Any questions, you can refer to FAQ firstly.

LED indicators

Jack/Port/Button	Description
USB	The USB port is used to connect devices that support USB 3.0, and can also support USB 2.0.
Reset/WPS	Reset : Keep pressing the Reset button for 8 seconds to start the Reset, the product will restore factory settings. WPS : Keep pressing the WPS button for 3 seconds to start the WPS, the product can quickly connect to other devices that support WPS terminals.
LAN 1/2/3/4	The LAN ports can connect wired devices such as computers or switches.
WAN	The WAN port can connect this router to the internet.
Power	The Power port can connect the power.

LED	Description
Power	Solid green: The device is ready. Off: The device does not start or is not powered.
2.4G	Solid green: 2.4GHz Wi-Fi is connected. Off: 2.4G Wi-Fi is not connected. Blinking green: 2.4G Wi-Fi is sending or receiving traffic.
5G	Solid green: 5GHz Wi-Fi is connected. Off: 5G Wi-Fi is not connected. Blinking green: 5G Wi-Fi is sending or receiving traffic.
WPS	Blinking green: WPS is turned on, waiting for terminal device to access. Off: WPS is turned off.

FAQ

1. Q: Why can't I log in to the web UI of the router?

A: Step 1: Please confirm your devices connect to the WIFI6-53B9_2.4G.

Step 2: Please confirm if your IP address is 192.168.1.1.

Step 3: Please confirm both the user name and password is "admin".

2. Q: How can I reset the router?

A: Method 1: Keep pressing the Reset button for about 8 seconds to restore factory settings.

Method 2: Please log in to the management page and click the "Reboot". In this interface, you can turn on WPS.

3. Q: How can I turn on WPS?

A: Method 1: Keep pressing the WPS button for about 3 seconds to start the WPS.

Method 2: Please log in to the management page and click the "Advanced Settings>Wireless>WPS".

4. Q: How to change my admin password?

A: Please log in to the management page (IP address is 192.168.1.1.) and click the "Advanced Settings>System Tools>Admin Password". In this interface, you can change the admin password.

5. Q: How to change my network name and password?

A: Please log in to the management page (IP address is 192.168.1.1.) and click the "Wireless". In this interface, you can change the network name and password.

6. Q: What if I forget the network password of the router?

A: Please reset the router and login in the router to set it up again".

7. Q: How can I select my connection type?

A: Please log in to the management page (IP address is 192.168.1.1.) and click the "Internet". In this interface, you can choose your connection type.

8. Q: What is the function of USB 3.0?

A: First, the router will charge your smart phone. Besides, the USB 3.0 port can connect a USB storage device, which can be either a USB drive or a portal hard disk. The USB storage device connected can function as a FTP or Samba server for file sharing and be accessed with a computer. You can also

manage the resources on the USB storage device with a computer.

9. Q: How can I select the time zone?

A: Please log in to the management page (IP address is 192.168.1.1.) and click the "Advanced Settings>System Tools>Time Settings". In this interface, you can choose the time zone.

10. Q: How can I add a Virtual Server?

A: Please log in to the management page (IP address is 192.168.1.1.) and click the "Advanced Settings>Nat Forwarding>Virtual Servers". In this interface, you can add a new virtual server.

11. Q: How can I turn on DHCP Server?

A: Please log in to the management page (IP address is 192.168.1.1.) and click the "Advanced Settings>Network>DHCP Server". In this interface, you can add a new virtual server.

12. Q: How can I turn on UPnP?

A: Please log in to the management page (IP address is 192.168.1.1.) and click the "Advanced Settings>UPnP". In this interface, you can turn on UPnP.

13. Q: How can I turn on DNS?

A: Please log in to the management page (IP address is 192.168.1.1.) and click the "Advanced Settings>DNS". In this interface, you can turn on DNS.

14. Q: How can I update the firmware?

A: Please log in to the management page (IP address is 192.168.1.1.) and click the "Advanced Settings>System Tools>Firmware Upgrade". In this interface, you can add the firmware file path and upgrade the firmware.

15. Q: How can I turn on DMZ?

A: Please log in to the management page (IP address is 192.168.1.1.) and click the "Advanced Settings>Net Forwarding>DMZ". In this interface, you can turn on DMZ.

