

ELECTRIC RICE COOKER

사용설명서
USER MANUAL

CR-0605F
1.08L(2~6 Persons)

CUCKOO

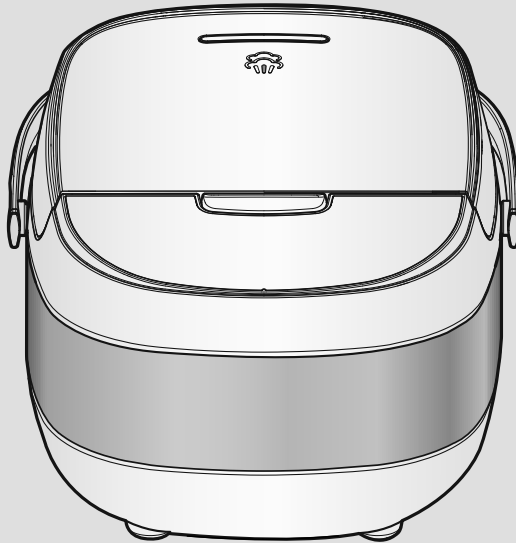

CUCKOO ELECTRONICS AMERICA, INC.

CONTENTS

CONTENTS

IMPORTANT SAFEGUARDS	3
SPECIFICATIONS	5
SAFETY PRECAUTIONS	6~7
PART NAMES	8
PANEL DISPLAY	9
BEFORE COOKING RICE	10
FOR TASTIER RICE	11
HOW TO START COOKING	12~13
HOW TO USE PORRIDGE	14
HOW TO USE CAKE	15
HOW TO USE SLOW COOK	16
HOW TO USE STEAM	17
HOW TO PRESET TIMER FOR COOKING	18
TO KEEP COOKED RICE WARM AND TASTY	19
HOW TO CLEAN AND MAINTAIN YOUR RICE COOKER	20~21

IMPORTANT SAFEGUARDS

When using electrical appliances, basic safety precautions should always be followed including the following:

- ▶ Read the user manual thoroughly.
- ▶ Do not touch hot surfaces. Instead, use the intended handles when adjusting the unit.
- ▶ To prevent electric shock, do not immerse the power cord or plug in any liquid.
- ▶ Close supervision is necessary when this product is used near children. This appliance is not intended for use by young children.
- ▶ Unplug from outlet when not in use and before cleaning. Allow to cool before putting on or taking off parts.
- ▶ Do not operate if the unit, power cord, or plug has been damaged. Return the unit to your nearest authorized service facility for examination and repair.
- ▶ Additional modifications to this unit is not approved and may cause injuries.
- ▶ Do not use outdoors.
- ▶ Do not let the power cord hang over an edge nor touch hot surfaces.
- ▶ Do not place the unit on or near hot gas/electric burner/oven.
- ▶ Extreme caution must be used when moving an appliance containing hot oil or other hot liquids.
- ▶ Always attach the power cord to the appliance, then plug into the wall outlet. To disconnect, turn any control to "off", then remove the plug from the wall outlet.
- ▶ Do not use the appliance for anything other than its intended use.
- ▶ Do not obstruct the steam vent hole with foreign objects.
- ▶ Do not place the inner pot directly over a flame for cooking.

SAVE THESE INSTRUCTIONS THIS APPLIANCE IS FOR HOUSEHOLD USE ONLY

ADDITIONAL IMPORTANT SAFEGUARDS

WARNING : This appliance generates heat and releases steam during use.
Use proper precaution to prevent risk of burns, fire, injuries, or damage to property.

1. Take extreme caution when opening the Lid after cooking. Severe burns can result from steam inside.
2. Never open the Lid while the unit is in operation.
3. Do not use without the inner Pot in place.
4. Allow the unit to completely cool down before touching the inner pot or any other heated parts.
This appliance is intended to be used in household and similar applications such as :
 - staff kitchen areas in shops, offices and other working environments;
 - farm houses;
 - by clients in hotels, motels and other residential type environments;
 - bed and breakfast type environments.

SHORT CORD INSTRUCTIONS

NOTE:

- A. A short power cord has been provided to reduce the likelihood of potential hazards.
 B. Longer power cords or extension cords are to be used with care as written below.
 C. Longer power cords or extension cords may only be used if:
 (1) the marked electrical rating of the power cord or extension cord is greater than or equal to that of the product
 (2) the power cord or extension cord is a grounding-type 3-wire cord
 (3) the power cord or extension cord is positioned so that it does not drape over the countertop or tabletop where it can easily be pulled or tripped over

CAUTION:

Preheating of the appliance is not necessary.
 During and shortly after use, the rice cooker's internal parts, steam vent, and the area around the steam vent are hot.
 Use caution when handling the appliance, and keep out of reach of children to avoid possible injury.





SPECIFICATIONS / 제품규격

Model Name / 모델명		CR-0605F
Power Supply / 정격전압		AC 120V(AC Only), 60Hz
Power Consumption / 소비전력	Cooking / 취사	600W
	Keeping Warm / 보온	235W
Cooking Capacity / 취사용량	백미 / WHITE	1~6 Persons
	백미쾌속 / QUICK	1~4 Persons
	현미 / 잡곡 / BROWN/MIXED	0.5~2.5 Persons
	자스민 / 장립미 / JASMINE / LONG GRAIN	1~6 Persons
	오토밀 / STEEL CUT OATS	0.5~2 Persons
	퀴노아 / QUINOA	0.5~2 Persons
	냉동보관밥 / STORED RICE	1~6 Persons
	죽 / PORRIDGE	0.5~1 CUP
Power Cord Length / 파워코드 길이		4 ft (1.2 m)
Dimensions / 제품의 크기		14.6(L) x 10.6(W) x 8.3(H) (inches) 370(L) x 268(W) x 210(H) (mm)
Weight		8.4 lbs (3.8 kg)

SAFETY PRECAUTIONS

CAUTION FOR SAFETY

- The following precautions must be applied in order to use the product safely and prevent dangerous situations.
- The definition of "Warning" and Caution are as follows:

 Warning	Failure to adhere to a warning may result in severe injury or death.	 • This symbol used to prevent the user from actions that may cause problems with the unit.
 Caution	Failure to adhere to a warning may result in injury or damage to property and/or the unit.	 • Means the following is prohibited.
		 • Means the following is an instruction.

Warning **Do Not**

Do not place the rice cooker near hot objects such as stoves, heaters, or direct sunlight.

- Failure to do so may result in electric shock, fire, unwanted changes to the unit and its function, and/or discoloration.
- Check the condition of the power cord frequently to ensure safe use.

This device is not intended for use by people who lack physical, sensory, and/or mental abilities needed to follow instructions and ensure safe use.

- Keep the unit out of reach of children.
- When used incorrectly, this device may result in electric shock, burns, and/or other injuries.

Do not repeatedly plug and unplug the power cord.

- Doing so may result in a fire.

Keep bodily parts away from the steam vent.

- Failure to do so may result in burns.
- Keep out of children's reach.

Do not bend, tie, or pull the power cord by force.

- Doing so may result in electric shock and may cause the unit to short circuit, further resulting in a fire.
- Check the condition of the power cord/plug frequently to ensure safe use.

Do not sprinkle water on the rice cooker.

- Doing so may cause electric shock and/or fire.
- If the unit comes in contact with water, separate the power cord from the unit and contact the dealer/service center.

Keep water and any chemicals away from the rice cooker.

- Failure to do so may result in electric shock and/or fire.

Do not open the lid while the unit is heating or cooking.

- Doing so may result in burns.

Use a single outlet with a current rating over 15A.

- Combining the rice cooker with other output sources in one outlet may cause overheating, resulting in a fire.
- Only use extension cords with a current rating over 15A.
- Check the condition of the power cord frequently to ensure safe use.

Do not use inner pots that are not designed for this rice cooker. Additionally, do not use the product without the inner pot.

- Doing so may result in electric shock and/or fire.

Do not insert foreign objects (other than food) into the unit.

- Doing so may result in electric shock and/or fire.

SAFETY PRECAUTIONS

CAUTION FOR SAFETY

 Warning  Do Not

Do not use it without the inner pot.

- Doing so may cause electric shock and/or unit malfunction.
- If rice or water gets inside the product, do not attempt to remove it by turning the unit over or shaking it. Instead, contact the dealer/service center.

Do not alter, disassemble, reassemble, or repair the product.

- Doing so may result in electric shock and/or injury.
- For repair, contact the dealer/service center.

Do not place the product near dusty areas or in the vicinity of chemical substances.

- Do not place the product near combustible gas/inflammables. Doing so may result in explosion and/or fire

Do not change, extend, or reconnect the power cord.

- This may result in electric shock and/or fire.

Do not move the unit by grabbing onto the power cord

- This may result in electric shock and/or fire.

Do not use the product if the power cord or plug is damaged. Do not plug the product into a loose outlet.

- Doing so may result in electric shock and/or fire.
- Check the condition of the power cord frequently to ensure safe use.
- If any mentioned part is damaged, contact the dealer/ service center.

Place the product on a secure platform.

- Do not wedge the power cord between a tight space. Doing so may result in electric shock and/or fire.
- Do not use the unit on furniture. Doing so may result in electric shock, fire, and/or property damage due to the automatically released steam.

Do not place on an angled platform.

- Doing so may result in electric shock, fire, and/or unit malfunction.
- Install the power cord in an open area.

Do not apply insecticide on the rice cooker.

- Doing so may result in electric shock and/or fire.
- If insects are found inside the rice cooker, contact the dealer/service center.

 Warning  Remember

Do not touch the plug or power cord with wet hands.

- Doing so may result in electric shock.

Be careful not to injure your hand when opening and closing the lid.

- Do not leave the lid opened. Doing so may result in injury.

Do not place heavy objects on the power cord.

- This may result in electric shock and/or fire.
- Check the condition of the power cord frequently to ensure safe use.

Take out the rice scoop before warming.

- Failure to do so may affect the color and smell of the rice.

Be careful not to damage the power cord.

- Do not allow pets near the power cord.
- Do not place sharp metal objects near the power cord.
- Doing so may result in electric shock and/or fire.
- Check the condition of the power cord frequently to ensure safe use.

Remove dust and residue from the power cord/plug with a clean cloth.

- Failure to do so may result in electric shock and/or fire.

Remove dust and foreign residue from the temperature sensor, heating plate and inner pot.

- Failure to do so may result in a fire and/or unit malfunction.

CAUTION FOR SAFETY



Caution



Do Not

Do not touch the metallic surface of the inner pot and/or heating plate during warming/after cooking.

- Doing so may result in burns.

Do not cover the steam vent with a towel, apron, etc.

- Doing so may result in unwanted changes to the unit and/or unit malfunction.

Use the warming function only when cooking white rice.

- Other foods are easily discolored.

Use the rice cooker for its intended use only.

- Failure to do so may result in unit malfunction

Do not drop nor put excessive force on the unit.

- Doing so may result in unit malfunction.

Do not use the product near a wall or furniture.

- Doing so may result in damage or discoloration to surfaces due to automatically released steam.

Do not use the cooker beyond its maximum capacity.

- Doing so may result in overflowing and/or unit malfunction.

Pull the plug out when the unit is not in use.

- Failure to do so may result in electric shock and/or fire.

Do not use the inner pot for other than its intended use.

- Doing so may:
 - affect the color and smell of the rice.
 - cause the inner pot to deform.
 - damage the inner coating.

Contact customer service if the coating on the inner pot peels off.

- The inner pot coating may wear down from extensive use over time.
- When cleaning the inner pot, do not use sharp or abrasive cleaning tools such as a metal brush.



Caution



Remember

Contact the dealer/service center if there is any sign of burning (smell, smoke, etc.).

- First, unplug the unit and separate the power cord from the unit

Keep the steam vent clear.

To prevent burns, wait until the unit has completely cooled down before cleaning.

If the "Cooking" button is not functioning, contact your representative/service center.

Clean the rice cooker after use.

- Failure to do so may affect the unit's performance.

Connect the AC connector to the product properly to ensure stable connection.

- Failure to do so may result in electric shock and/or fire.

PARTS & ACCESSORIES

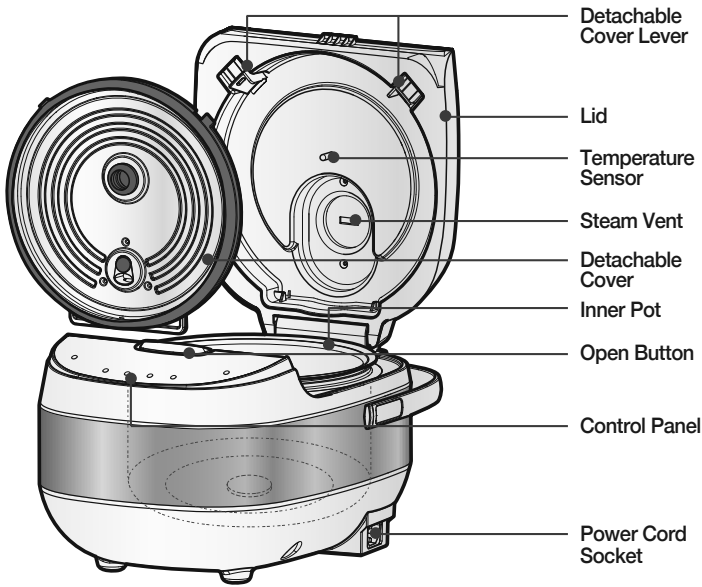

Accessories

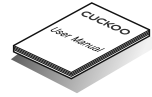

User Manual



Spatula



Measuring Cup

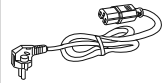

Power Cord

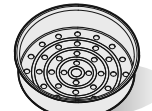

Steam Tray

Detachable Cover

(1) Disassembling the Detachable Cover

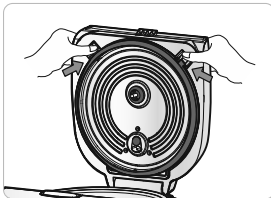

► To disassemble the Detachable Cover, push both Detachable Cover Levers up.

(2) Assembling the Detachable Cover

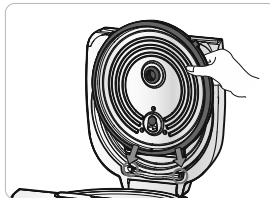

► First, align the bottom of the Detachable Cover with the grooves on the inner lid as shown in the photo above.

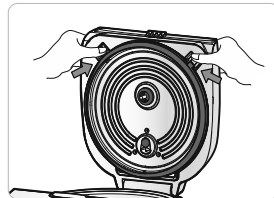

► Next, push lightly on the upper part of the Detachable Cover to lock it in place.

PANEL DISPLAY

Panel Display

WARM/REHEAT

Press to warm or reheat previously cooked food

DISPLAY

MENU

Press to select a cooking mode: STEAM, STORED RICE, PORRIDGE, STEEL CUT OATS, QUINOA, or AUTO CLEAN

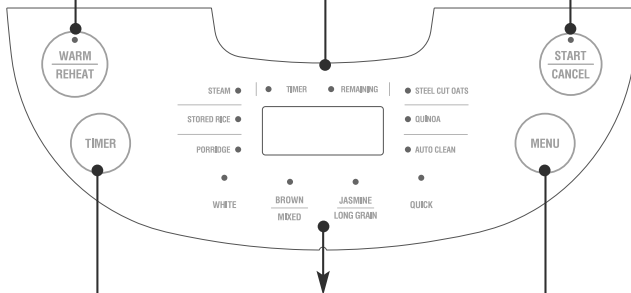

TIMER

Press to select the desired cooking completion time

DIRECT MENU

Press to select a direct menu: WHITE, BROWN/MIXED, JASMINE/LONG GRAIN, or QUICK

MENU

Press to select a cooking mode: STEAM, STORED RICE, PORRIDGE, STEEL CUT OATS, QUINOA, or AUTO CLEAN

- ※ If the unit remains motionless after it has been plugged in, it is on standby until the screen turns on.
(The standby screen may differ due to the user's previous settings)
- ※ If the CANCEL button is pressed while selecting a setting, the unit will go into standby mode.
- ※ Press the buttons until you hear a buzzer sound.
The design of this template may differ from the actual product.



< Standby Mode Screen >

Error Notifications

Error notifications may appear if product is not working properly.



Temperature sensor issue.
(Consult the service center and dealer)

BEFORE COOKING RICE

1 Clean the inner pot and remove all residual moisture.

- ▶ Clean the inner pot with a dry dishcloth.
- ▶ Cleaning with an abrasive material may damage the surface of the inner pot.

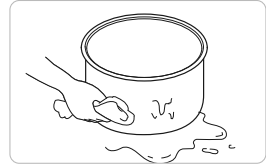

2 Measure the rice with the provided measuring cup. Use the measuring cup accurately as shown in the picture.

- ▶ Recommended serving: 1 full cup of rice per person
(Example: 2 cups for 2 people)



3 Rinse the rice in a separate container until the water runs clear.

4 Add water to the inner pot.

5 Add water to the inner pot.

- ▶ Place the inner pot on a flat, level surface and add water according to the water level lines.
- ▶ Read the water level lines as written below:
 - White Rice, TURBO: Add water to match the "WHITE RICE" water level lines.
 - Thick Porridge: Add water to match the "THICK PORR." water level lines. The maximum capacity for Thick Porridge is 1.5 cups.
 - Thin Porridge: Add water to match the "THIN PORR." water level lines. The maximum capacity for Thin Porridge is 1 cup.
 - WHITE, JASMINE/LONG GRAIN, QUICK, STORED RICE: Adjust water based on 'WHITE RICE' water level line. (Max.6 persons)
 - Porridge: Adjust water level to the water scale for 'PORRIDGE'. (Max.1 persons)
 - BROWN/MIXED: Adjust water based on 'BROWN RICE' water level line. (Max.2.5 persons)
 - STEEL CUT OATS
 - QUINOA

PERSONS	STEEL CUT OATS	Choice 1.	Choice 2.
		WATER	MILK
0.5	67.5g	225ml (about 1+1/4cups)	180ml (about 1cup)
1	135g	360ml (about 2cups)	315ml (about 1+3/4cups)
2	270g	585ml (about 3+1/4cups)	540ml (about 3cups)

PERSONS	QUINOA	WATER
0.5	67.5g	123ml (about 2/3cups)
1	135g	215ml (about 1+1/5cups)
1.5	202.5g	306ml (about 1+2/3cups)
2	270g	397ml (about 2+1/5cups)

※ Please use the measuring cup provided with the product.

- For 6 persons (1.08L) product

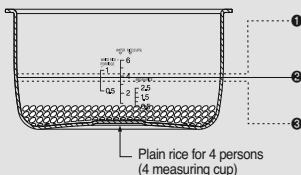

- 1 Add more water than the water level lines when cooking sticky rice or old rice.
- 2 The numbers of the water level lines represent cups of rice added.
- 3 Add less water than the water level lines when the rice has soaked sufficiently or when fluffier rice is desired.
- 4 Results can vary depending on the moisture content of rice (older rice is lower in moisture). Adjust the water level by 1~10% if the rice is undercooked/overcooked.



6 Place the inner pot into the product and completely close the lid.

- Make sure the inner pot has been properly placed into the product.
 - ▶ Rice will not cook properly if there is residue on the bottom of the rice cooker/inner pot.

FOR TASTIER RICE

How to Cook Tastier Rice

► Observe the following instructions for tasty rice:

<p>Measure rice with a measuring cup. Pour water up to the correct water level using the lines of the inner pot.</p>	<ul style="list-style-type: none">•Add the desired amount of rice using the provided measuring cup.•Place the inner pot on a flat, level surface and add water to the correct water level line.	<p>Your rice may be undercooked or overcooked depending on the amount of water that was added.</p> 
<p>Store rice correctly.</p>	<ul style="list-style-type: none">•Purchase rice in small quantities at a time to ensure freshness.•For dry, stale rice, it is recommended to add extra water (about a half water level line more).	<p>If the rice is dry, add more water.</p>
<p>Reduce the duration of Timer Cooking</p>	<ul style="list-style-type: none">•For stale rice, avoid timer cooking if possible and add extra water (same as above).	<p>Using Timer Cooking for over 10 hours with dried rice may cause it to be undercooked, burnt, or cooked unevenly.</p>
<p>Do not exceed 12 hours in “Keep Warm” mode</p>	<ul style="list-style-type: none">•Exceeding 12 hours in “Keep Warm” mode may decrease the quality of your rice. 	<p>Exceeding 12 hours in the “Keep Warm” mode may cause discoloration of the rice.</p>
<p>Keep your pressure cooker clean at all times</p>	<ul style="list-style-type: none">•Clean your pressure cooker frequently. Wipe all residue from the unit after every use.	<p>Not cleaning your rice cooker can compromise the quality of your rice.</p>

HOW TO START COOKING

1 Press the MENU button or DIRECT MENU button to select your desired cooking mode.

- Whenever the FUNCTION button is pressed, the cooking options will be highlighted in sequential order from STEAM, STORED RICE, PORRIDGE, STEEL CUT OATS, QUINOA, AUTO CLEAN.
- Whenever the FUNCTION button is pressed, the cooking options will be highlighted in sequential order from WHITE, BROWN/MIXED, JASMINE/LONG GRAIN, QUICK.

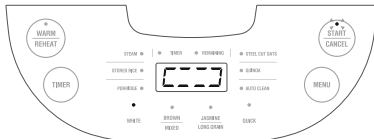

Example) Selection of WHITE

2 Press the START/CANCEL button to start cooking.

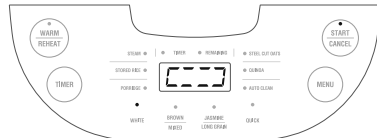

Example) Selection of WHITE

3 Check the remaining cooking time.

- The remaining cooking time can be found on the display. Cooking time may vary depending on the menu.



Example) Remaining cooking time of WHITE

4 Completion

- When the cooking is completed, you will be notified with a beeping sound. WARM Mode is automatically activated after cooking.
- Stir the rice evenly after cooking.
- Unless an emergency occurs, do not press the CANCEL button while cooking.



Cooking Time by Menu

Menu	WHITE	BROWN/MIXED	JASMINE/LONG GRAIN	QUICK	STEAM	STORED RICE	PORRIDGE	STEEL CUT OATS	QUINOA	AUTO CLEAN
Cooking Quantity	1~6 persons	0.5~2.5 persons	1~6 persons	1~6 persons	Refer to Page 14	1~6 persons	0.1~1 cup	0.5~2 persons	0.5~2 persons	Refer to Page 13
Cooking Time	30~54min.	50~63min.	30~53min.	30~49min.		26~40min.	90 min.	20~44min.	48~55min.	

► The cooking time may vary depending on which cooking mode is selected.

HOW TO START COOKING

Cooking Menu

WHITE	For short grain white rice	BROWN/MIXED	For brown or mixed rice
JASMINE/ LONG GRAIN	For jasmine rice and long grain white rice	QUICK	For cooking white rice in a short amount of time
STEAM	For steaming food	STORED RICE	For rice that is intended to be pre-cooked, frozen, and stored
PORRIDGE	For porridge	STEEL CUT OATS	For steel cut oats
QUINOA	For quinoa		

The Searing Effect

The bottom layer of rice may darken in color while cooking as it is exposed to high levels of heat. This does not mean that the rice cooker is defective. This phenomenon is more prevalent when using the TIMER mode.

How to Use AUTO CLEAN

1. Add water to the inner pot to match the water level line 2.
2. Close and lock the lid.
3. Press the AUTO CLEAN button.
4. Press the START/CANCEL button to begin.



HOW TO USE STEAM

1 Press the MENU button until the STEAM LED lights up.

- ▶ When STEAM is selected, the display will show the cooking time as 30 minutes.



2 Press the START/CANCEL button.

- ▶ The cooking will begin after the water is adequately heated.
- ▶ When preheating is complete, the display will show a blinking " : ". This means that the cooking will begin.

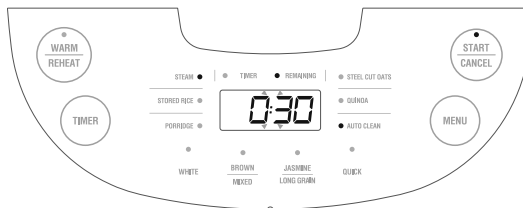

HOW TO USE STORED RICE

What is STORED RICE?

This function is used to make rice that will taste freshly cooked after being frozen and thawed.

How to Use STORED RICE

- 1 Press the MENU button to select STORED RICE.**

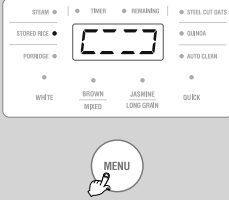

The control panel displays various cooking options: STEAM, THERM, REMAINING, STEEL CUT OATS, STORED RICE (selected), GINGER, POPPADUM, AUTO CLEAN, WHITE, BROWN MIXED, JASMINE LONG GRAIN, and QUICK. A hand icon points to the MENU button below the panel.
- 2 Press the START/CANCEL button to start cooking.**



A circular button with the text 'START' and 'CANCEL' is shown. A hand icon points to the button.
- 3 When cooking is complete, open the lid and stir the cooked rice thoroughly. Next, move the cooked rice into a microwavable container and place it in a freezer to preserve.**



The control panel shows the cooking cycle completed. The display shows '0:00'. The STORED RICE menu is still selected. A hand icon points to the MENU button below the panel.

Precautions When Cooking STORED RICE

- 1** When using the STORED RICE menu, refer to the water level used when cooking white rice. The maximum cooking capacity for STORED RICE is 4 servings.
- 2** When the rice has been completely cooked, open the lid and stir the rice thoroughly.
- 3** Move the cooked rice into microwavable containers in single serving portions (210g), and place them into the freezer for preservation.
- 4** When microwaving your Frozen Stored Rice, open the lid of the microwavable container slightly and heat for 3 min 30 sec (per serving). (Heating time may differ due to amount of rice, size of container, microwave output, etc.)
- 5** Please note that the quality of your rice may be affected as the storage period increases.

Precautions

- Do not cook beyond the maximum capacity.
- Cooking beyond the maximum capacity may result in the overflowing of rice and water.
- Do not remove the detachable cover right after cooking is completed as it may cause burns.

HOW TO USE THE PRESET TIMER

Setting the Preset Timer

1 Select the desired cooking menu.

- ▶ Available Menus : WHITE, BROWN/MIXED, JASMINE/LONG GRAIN, QUICK, STEAM, PORRIDGE, AUTO CLEAN

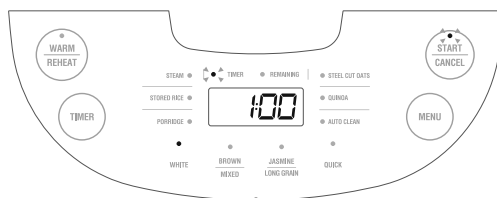

ex) When the preset time is set to 2h on the WHITE Menu

2 Press the TIMER button.

- ▶ The TIMER lamp will begin flashing.

3 Press the TIMER button again to set the timer.

- ▶ The longest available preset time is 24h.
- ▶ TIMER button to change the time increases by 10 minutes unit.
(1:00 → 1:10 → 1:20 → ... → 23:50 → 24:00 → 1:00 → ...)
- ▶ Holding down the TIMER button will allow you to change the time faster.

4 Press the START/CANCEL button.

- ▶ Cooking will be completed at the set time.
(The time of completion may vary slightly depending on a variety of factors, such as the amount of rice cooked and environment.)

Precautions When Using the Preset Timer

1 Please note the following.

- ▶ If the rice you are using is old and dry, using the TIMER may decrease the quality of rice.
- ▶ Add more water by half a water level line if the rice is undercooked.
- ▶ The “searing effect” may be more pronounced when using the Preset Timer for long periods of time.

2 Changing the Preset Time

- ▶ To change the preset time on the TIMER, press the START/CANCEL button and repeat the steps shown above (Setting the Preset Timer).

3 Please refer to the chart below for the appropriate preset times for each menu.

Available Preset Times for Each Menu

MENU	WHITE	BROWN/MIXED	JASMINE/ LONG GRAIN	QUICK	STEAM	PORRIDGE	AUTO CLEAN
Preset Time	1 hour~24 hours	90 min~ 24 hours	1 hour~24 hours	1 hour~24 hours	1 hour~24 hours	90 min~ 24 hours	1 hour~24 hours

HOW TO KEEP RICE WARM AND TASTY

Using the WARM/REHEAT Function

- ▶ To reheat rice that has already been cooked, press the WARM/REHEAT button two times while the rice cooker is on Standby Mode.
- ▶ After selecting WARM/REHEAT, the rice cooker will begin reheating in 5 seconds and will finish in 25 minutes.

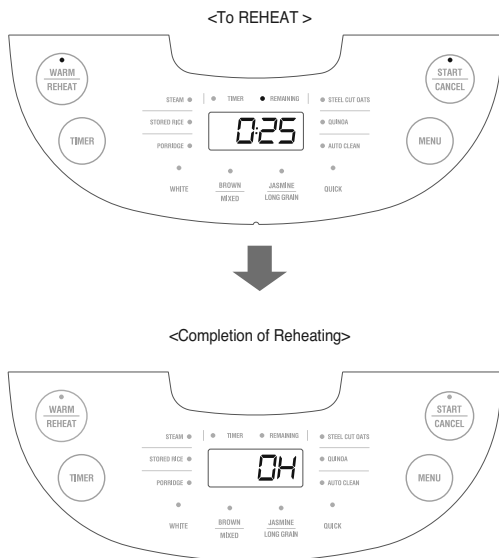

After reheating is completed, the rice cooker will automatically enter WARM mode. The elapsed warming time is displayed on the panel.

- ▶ The frequent use of the REHEAT function may cause the cooked rice to be discolored or dried. Use it once or twice per day.
- ▶ If a separate heating appliance or gas burner is used to cook rice, put the cooked rice into the cooker and press the WARM/REHEAT button to keep the rice warm. At this time, "0:00" is shown on the display. Please note that transferring hot rice to a cold rice cooker may cause the rice to become discolored or develop an odor.

Precautions When Reheating or Warming

Evenly mix the cooked rice after warming. When warming a small quantity of rice, pile the rice at the center of the inner pot.

Do not keep the rice spatula in the inner pot while warming. This may cause bacteria to form.

Do not mix small quantities of leftover rice together to warm. Doing so may result in unwanted odors in the rice.
(Use a microwave instead.)

Keeping rice warm for a long time may cause the rice to be discolored or develop an odor. So, it is recommended to keep warm for less than 12 hours.

After 12 hours of warming, the product will automatically switch from Keep Warm Mode to Standby Mode.

The warming status of mixed/brown rice is worse than plain rice. Do not keep it warm if at all possible. The rice on the edge of the inner pot or the bottom of the steam outlet may turn plain and swollen. In this case, stir and mix the rice.

HOW TO CLEAN AND MAINTAIN YOUR RICE COOKER

Maintaining Your Rice Cooker

The inner pot contains a non-stick fluorocarbon coating in order to prevent rice from sticking to the pot.

- Only use a smooth plastic rice paddle as provided with the unit.
- Do not use any metal utensils or dishware in the product.
- Do not use any commercial cleaner.
- Any residual seasoning or sauce must be washed off the inner pot immediately.
- It is normal for the inner pot to stain after extended use. This does not mean the inner pot needs to be replaced.

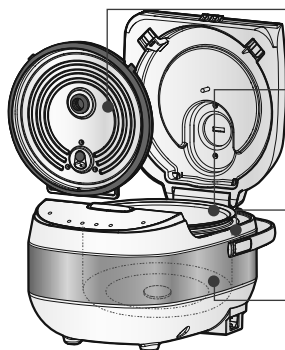

Disassemble and clean the Detachable Cover and the Steam Vent after every use.

When storing the rice cooker or using it to cook or warm, ensure that the outside of the inner pot is completely dry. Residual moisture on the inner pot can lead to staining.

Any moisture that has collected while cooking must be removed. Failure to do so may result in unwanted odors.

Remove any residual food and moisture from the product. Failure to do so may damage the temperature sensor and the heating element.

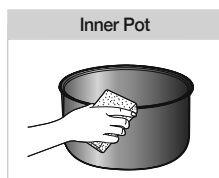

Wipe all residue from the outside of the inner pot. Using an abrasive cleaner may result in the damage of the non-stick coating.

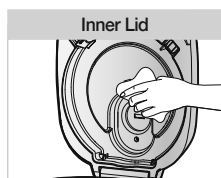

Wipe the residual moisture from cooking with a dry dishcloth. Be careful as the edge of the lid is made of metal.

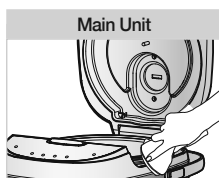

The condensation from cooking will collect where the lid meets the main body. Wipe this area with a dry dishcloth after every use.

※ CAUTION

Do not clean the inner pot with sharp objects such as spoons or chopsticks. Doing so will damage the coating.

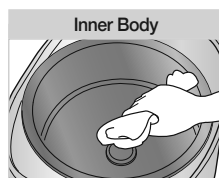

If residual food is stuck to the temperature sensor or on the heating element, remove it by using a moist cloth.

Cleaning the Steam Vent

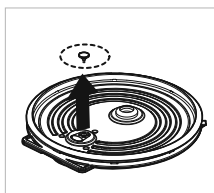

▶ Disassemble the Steam Vent Seal.

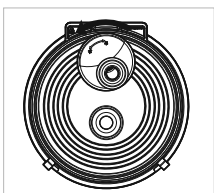

▶ Turn the Steam Vent counterclockwise as shown in the photo above.

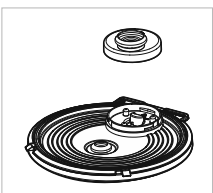

▶ Disassemble the Steam Vent from the Detachable Cover.

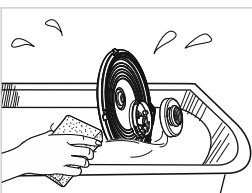

▶ Submerge the Steam Vent and the Detachable Cover in lukewarm water and use a soft cleaner to wash off residue.
▶ To assemble, follow the previous steps in the opposite order.

CUCKOO

