

# HD SERIES

## LOG SPLITTERS



# TIMBERWOLF

FIREWOOD PROCESSING EQUIPMENT



607-307-4029

[www.TimberwolfEquip.com](http://www.TimberwolfEquip.com)



- ▲ The ergonomic design allows operators to split for hours on end without being hunched over
- ▲ Essential for the self-employed operator looking to split more without the extra labor
- ▲ Built with a valve cover and large hydraulic tank for maximum durability
- ▲ Capable of outputting \$450 worth of firewood in just one hour



## FEATURES



### Power

- Choose 4" or 5" bore
- Hydraulic pump flow of 22 GPM
- Valves and hoses protected by cover to increase durability against the elements

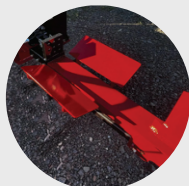

### Splitting Chamber

- Self-centering splitting chamber ensures that logs of any size are perfectly positioned prior to being split
- Creates a safer and more efficient user experience



### Hydraulic System

- Wedge Lift with 8" of vertical range
- Log Lift capable of lifting up to 500 lbs
- 25 gallon tank to maintain cool and filtered fluid



### Table Grate

- 32" long, constructed from heavy gauge pipe and High Steel plate steel
- Cleans out debris from split firewood, and catches logs for resplitting

All HD Series Log Splitters come standard with a 4-Way Wedge, Table Grate, and Hydraulic Log & Wedge Lift.

## SPECIFICATIONS & DIMENSIONS

Base Model	TW-3 HD	TW-5 HD
Engine Power (HP)	PTO (min 32)	12
Pump Flow (GPM)	22	22
Stroke (in.)	26	24
Cylinder Bore (in.)	4 or 5	4
Splitting Force (lbs)	37,700/58,905	37,700/58,905
Average Output (Cord/Hr)	1.5	1.5
Dimensions (H"xW"xL")	30"x46"x90"	41"x46"x90"
Weight (lbs)	1750	1750
Cycle Time (sec)	8/10	8/10

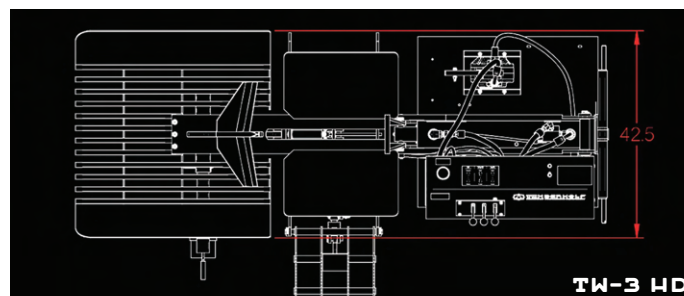
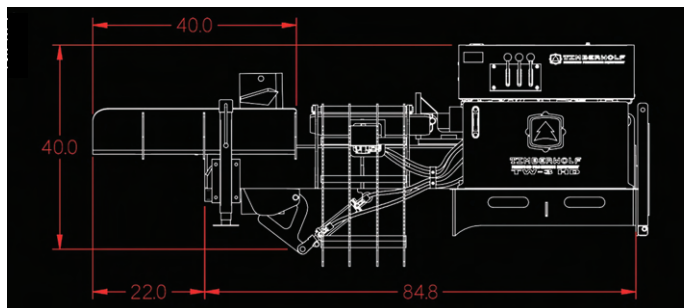

TW-3 HD