

Matrix

HIGH POWER ROCKET KIT

The Matrix kit contains all the parts necessary* to build a flying high power rocket:

- (1) Pre-slotted main airframe
- (1) Pre-slotted motor mount airframe
- (1) Airframe coupler tube
- (1) Coupler bulkplate
- (1) Coupler hardware set
 - (1) Eyebolt
 - (1) Washer
 - (2) Nuts
- (1) Nose cone
- (3) Upper fins
- (3) Lower fins
- (6) Canard fins
- (1) Piston ejection kit:
 - (1) Piston tube
 - (1) Slotted bulkplate
 - (1) Piston strap
 - (1) D-ring
- (1) Parachute
- (1) Motor mount tube
- (1) Airframe to MMT centering ring
- (1) Notched airframe to MMT cent. ring
- (1) Shock cord
- (2) Launch lug
- (1) Decal sheet
- (1) Instruction sheet (this one!)

*Epoxy, paint, and motor not included.



Please read and understand all instructions before building!

The center of pressure (CP) of this rocket is 43 inches from nose tip. After finishing your rocket, permanently mark the center of pressure on the airframe. After loading the rocket with a motor, make sure that the center of gravity (balancing point) is at least one body diameter forward of the center of pressure mark. The center of gravity can be moved forward by adding weight to the nose cone.



Copyright Public Missiles Ltd. 2000

Basic Construction FAQ

The major parts involved in each step are shown shaded at the beginning of that step. Areas where epoxy should be applied are shown as well.

PREP & ASSEMBLY

Read and understand the instruction steps fully before you begin the step.

ALWAYS sand the parts to be bonded with 100-120 grit sandpaper.

We strongly recommend you dry-fit (assemble without gluing) all parts in each step

BEFORE epoxying them together. Sand or adjust fit as needed before gluing.

Most epoxies work fine. Use 5 or 15 minute depending on how quickly you feel you can complete the step. Use longer set-time epoxy if you're unsure.

To make internal fillets to the fins deep up into the airframe, "load up" the end of a dowel with a blob of epoxy, then stick the dowel into the airframe and onto the fin joint you're working on. After depositing enough epoxy in this fashion, you can pull the dowel toward you, making a fillet with the rounded edge of the dowel.

Be sure to follow the "Do's & Don'ts" sheet provided with QT tubing.

Fins do not need to be "shaped". Lightly sand the edges to remove any manufacturing burrs.

PAINTING/FINISHING

Before you paint the fins, scuff the entire surface with 220 grit sandpaper. This is easiest to do before mounting the fins.

Plastic nosecone imperfections can be filled with plastic model kit putty.

Stay with the same brand of paint throughout the process; primer, base color, accent colors, and clear coat. DO NOT skimp on the "shake the can for at least two minutes after the ball rattles" step! For the best finish, let each coat dry overnight and sand lightly with 320 or 400 grit sandpaper.

Apply the last color coat as heavy as possible without running or sagging. Let the paint cure for at least 48 hours before handling!

We recommend a clear coat of some sort to help protect the decals as well as "seal" their edges to help prevent them peeling off. When using any clear coat, put on only VERY thin, light coats, and wait at least 5 minutes between coats. The clear coat can damage your decals or paint if you put it on too heavily or don't wait long enough between coats!

FINAL FITTING/PREPARATIONS FOR FLIGHT

The piston should be a smooth slip-fit in the airframe; this is critical. Sand the piston as needed so it can be easily inserted, and pulled out with just a gentle tug on the shock cord. Keep sandpaper in your range box in case you need to adjust the fit the first few times at the field to deal with differing temperature and humidity.

Couplers should also be sanded to allow easy separation of the rocket.

If the coupler or nosecone is too loose, use masking tape to build it up to a good fit. If the nosecone is too tight, sand the ribs on the shoulder until it fits well. The parts fit properly if the rocket can be held upside down and gently shaken with nothing moving or coming apart.

Ejections will leave a black, gritty residue inside the airframe. Occasionally wipe the tube interior with a damp cloth wrapped around a dowel or broomstick; allow to dry.

See our website FAQ for information about thrust rings and motor retention. Motor recommendation information is available on our website on the Specs Page.

For our complete FAQ, see the FAQ Page on our website at www.publicmissiles.com.

www.publicmissiles.com

The PML Web Store and Knowledge Base

Other items you will need:

One set of epoxy
One sheet each 120 and 220 sandpaper
Ruler and pencil

Masking tape
Cellophane tape

**Please read and understand all instructions before continuing!
All surfaces to be bonded must be scuffed with 120 grit sandpaper.**

Step 1

Dry fit both centering rings into the airframe and dry the motor mount tube. The notched ring can be a little snug in the airframe and on the motor tube. If it is tight, sand the ID and/or OD for a better fit. The standard centering ring should be a little looser in the airframe and over the motor mount tube to aid in later removal. Sand the ID and/or OD for a looser fit if necessary.

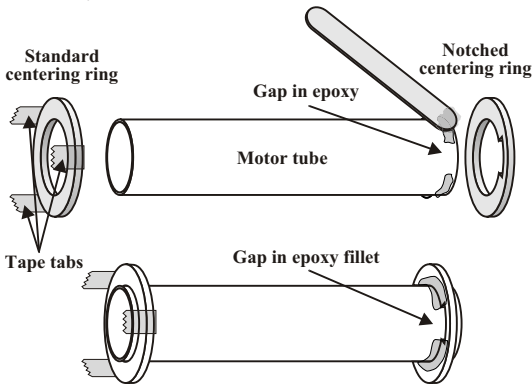

Spread a bead of epoxy around the circumference of one end of the motor tube leaving a 1" gap in the bead for the notch in the centering ring. Slip the notched centering ring over the motor tube with the notch aligned with the gap in the epoxy bead. Be sure the notch in the ring remains clear of epoxy. Locate the ring 1/2" from the end of the motor tube and allow the epoxy to set. Apply an epoxy fillet to each side of the ring still keeping the notch clear.

Slide the standard centering ring over the motor tube until 1/8" of the motor tube is protruding beyond the ring. Make 3 or 4 tabs using cellophane tape as shown above to aid in removing this ring later. Do not use any glue at this time, this centering ring will be removed in a subsequent step.

Step 2

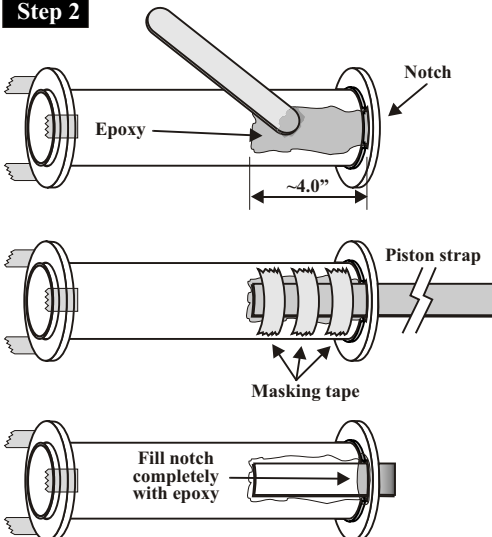

Spread a layer of epoxy about 1" wide and 4" long on the motor tube just below the notch in the upper centering ring. Slip one end of the piston strap (the widest strap in the kit) through the notch in the centering ring. Pull through about 4" of this strap through the notch and press it firmly into the epoxy on the side of the motor tube. Hold the strap in place against the tube with masking tape until the epoxy cures. Remove the masking tape. **Fill the entire centering ring notch with epoxy.** Stuff the free end of the strap into the motor tube to keep it out of the way for the next step.

Step 3

You will need a long stick or dowel for applying epoxy in this step. Just below is a drawing of one good method for creating an extended epoxy applicator. Simply epoxy a dowel or stick to a tongue depressor or popsicle stick.

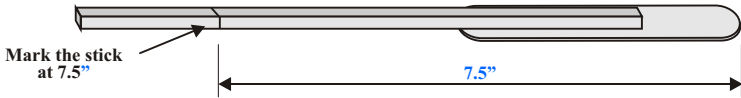

Make a mark on the stick at 7.5" so you can tell how deep the stick is in the airframe when spreading the epoxy. Using your extended epoxy applicator, spread a bead of epoxy around the inside circumference of the airframe 7.5" from the bottom of the airframe.

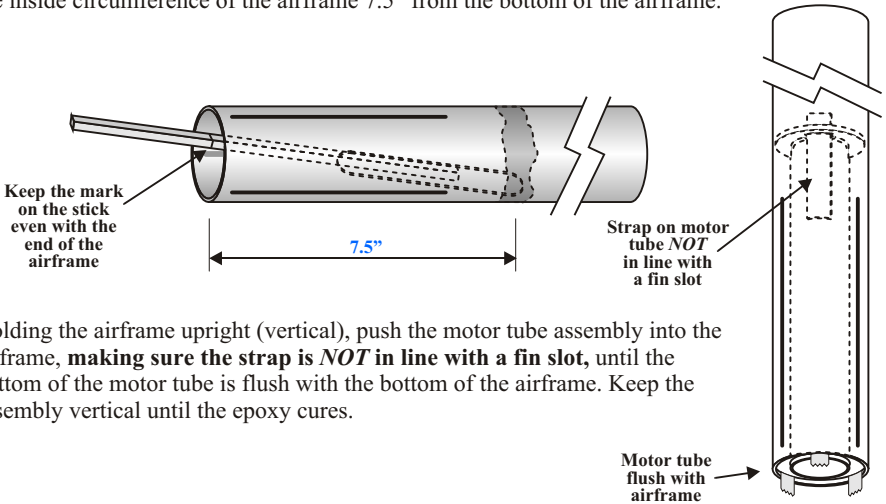

Holding the airframe upright (vertical), push the motor tube assembly into the airframe, **making sure the strap is NOT in line with a fin slot**, until the bottom of the motor tube is flush with the bottom of the airframe. Keep the assembly vertical until the epoxy cures.

Step 4

A) Apply a bead of epoxy to the root edge of one of the lower fins. Push the fin through the slot in the airframe and against the motor mount tube. Make sure that the fin is perpendicular to the airframe. Use tape to hold the fin in position while the epoxy cures. Repeat this process for all three lower fins.

B) Apply a small bead of epoxy to the root edge of one of the upper (long triangular) fins. Set the fin into one of the long dado slots. Make sure that the fin is aligned with the lower fin. Use tape to hold the fin in position while the epoxy cures. Repeat this process for all three upper fins.

C) Apply an epoxy fillet to both sides of each fin. Carefully smooth the epoxy with your finger before it begins to gel. Allow the epoxy to set up before rotating the rocket to do the next set of fins. Once the epoxy has fully cured, you should sand the fillet smooth with fine sandpaper. Sanding will help the primer hold better to the epoxy.

D) Gently pull the centering ring off the end of the rocket by tugging on the tape tabs. Using a stick, apply an epoxy fillet to the fins at the motor mount tube and the inner airframe wall.

E) Remove the tape tabs from the centering ring and permanently epoxy it in the base of the rocket 1/8" in from the bottom of the airframe.

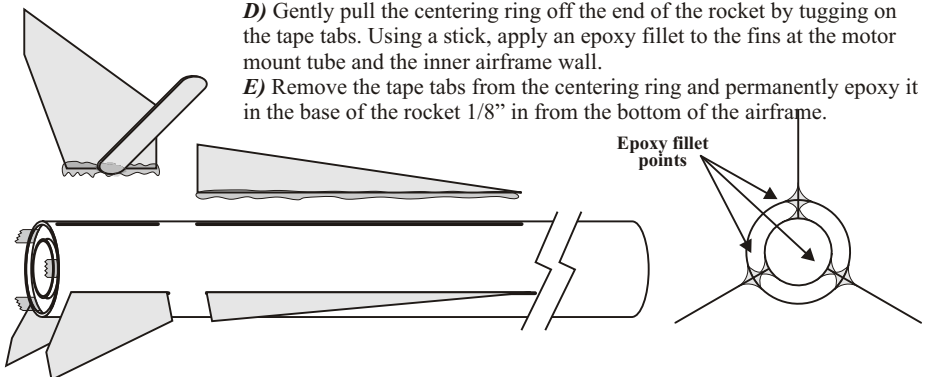

Step 5

NOTE: In this step you will be using the free end of the strap that you mounted to the motor tube assembly.

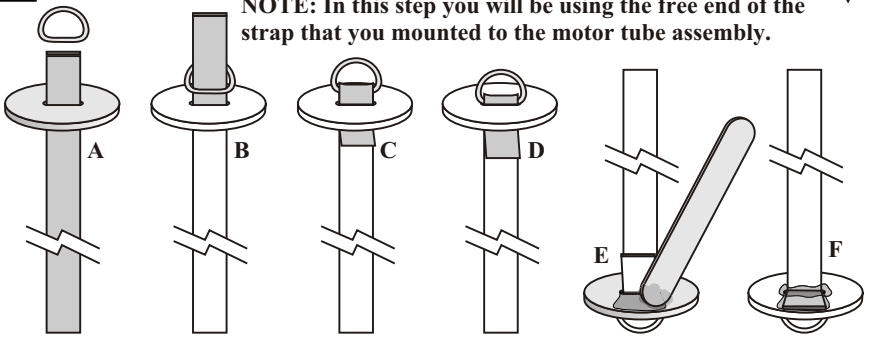

A) Pull the free end of the strap through the slot in the piston bulk plate.

B) Slip the metal "D" ring over the strap.

C) Feed the strap back through the slot.

D) Pull on the strap until the "D" ring is wedged at the slot.

E) Flip the assembly over. Spread a layer of epoxy on the underside of the piston plate as shown. Fold the short end of the strap flat against the piston plate and press it into the epoxy. You can use a clamp to hold the strap in the epoxy while it sets.

F) When the epoxy has cured, pull the strap until the "D" ring is wedged tight at the slot. Apply epoxy to the strap at the "D" ring.

G) Epoxy the piston plate inside the piston body 1/8" from the top.

H) Apply an epoxy fillet to both sides of the piston plate.

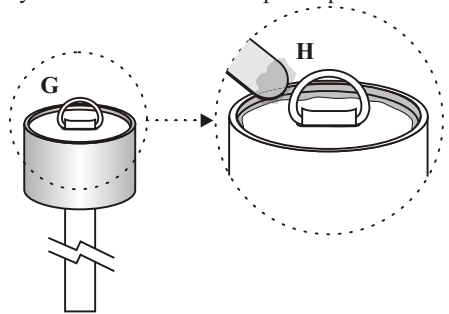

Step 6

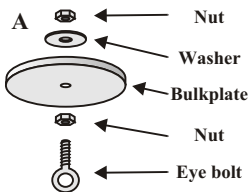

Assemble the bulkhead as shown in the drawing on the left.

A1) Thread a nut onto the eye bolt as far as it will go.

A2) Push the eye bolt into the hole in the bulkplate.

A3) Slip the washer onto the eye bolt.

A4) Thread the second nut on to the eye bolt and tighten it with a wrench.

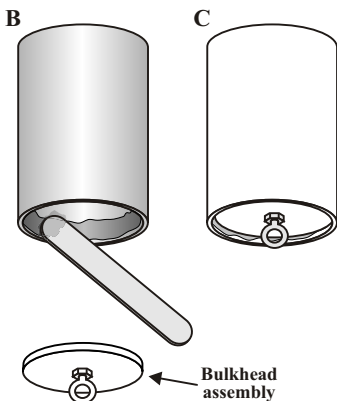

B) Spread a layer of epoxy around the inside circumference of the coupler to a depth of about 1/2".

C) Push the bulkhead assembly into the coupler until it is about 1/4" past the edge. Allow the epoxy to set.

D) Apply an epoxy fillet to both sides of the bulkhead.

E) Draw a pencil mark at the mid-point of the coupler.

Pencil mark
at the mid-point
of the coupler

Step 7

A) Apply a small bead of epoxy to the root edge of one of the canard fins. Set the fin into one of the dado slots on the payload section. Make sure that the fin is perpendicular to the airframe. Use tape to hold the fin in position while the epoxy cures. Repeat this process for all six canard fins.

B) Apply an epoxy fillet to both sides of each fin. Carefully smooth the epoxy with your finger before it begins to gel. Allow the epoxy to set-up before rotating the rocket to do the next set of fins. Once the epoxy has fully cured, you should sand the fillet smooth with fine sandpaper. Sanding will help the primer hold better to the epoxy.

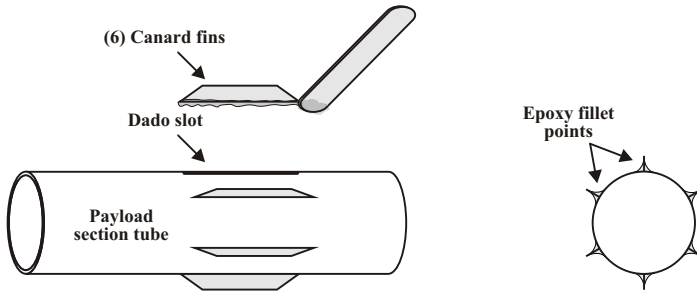

Step 8

Locate the end of the payload section where the canard fins are 4.75" from the end of the tube. At this end, spread a layer of epoxy around the inside circumference of the payload section tube to a depth of 1/2 of the tube diameter. With a slow twisting motion, push the coupler into the payload section tube up to the pencil mark. Allow the epoxy to set.

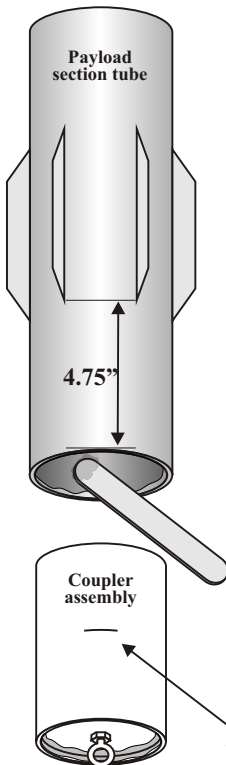

Slip the nosecone into the top of the payload section tube. Secure the nosecone to the payload section with 3 small screws or removable plastic rivets equally spaced around the circumference of the payload section tube about 1" below the top of the airframe. Be sure to pre-drill holes of the appropriate size when using screws. 1/4" long sheet metal screws work well in this application. If you prefer to use PML Removable Plastic Rivets (RVT-24), you will need to drill 5/32" diameter holes. Next drill a 1/8" or 5/32" hole near the base of the payload section tube completely through the coupler. This hole is needed for high speed, high altitude flights to bleed off internal air pressure.

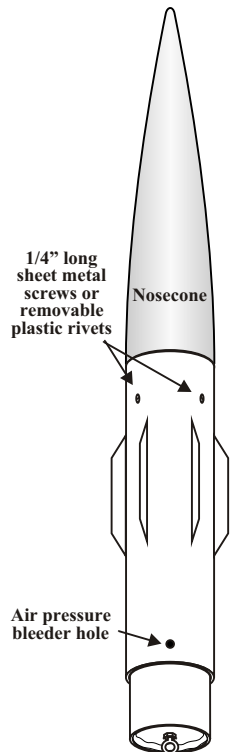

Step 9

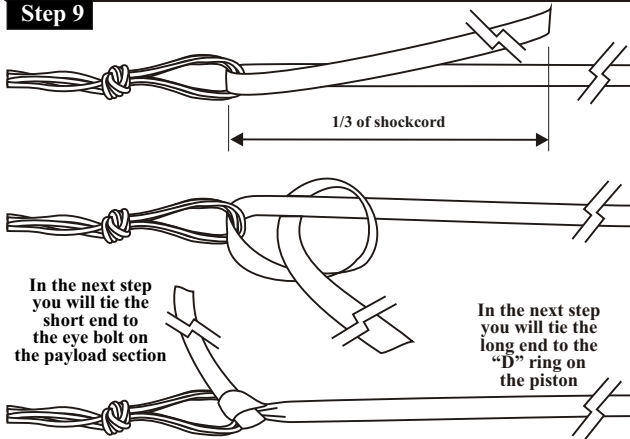

Prepare the parachute per the parachute instructions. Thread the shock cord through the loop you made in the parachute shroud lines and tie it using the knot illustrated on the left. Note that the chute should be attached to the shock cord at about the 1/3 point of the shock cord. Alternatively, you can tie the shock cord to a "kwik-link" and then attach the "kwik-link" to the loop in the shroud lines.

Step 10

Thread the long end of the shock cord through the "D" ring and tie it using the knot illustrated below. Alternatively, you can tie the shock cord to a "kwik-link" and then attach the "kwik-link" to the "D" ring. Use the same knot to attach the other end of the shock cord to the eye bolt on the payload section.

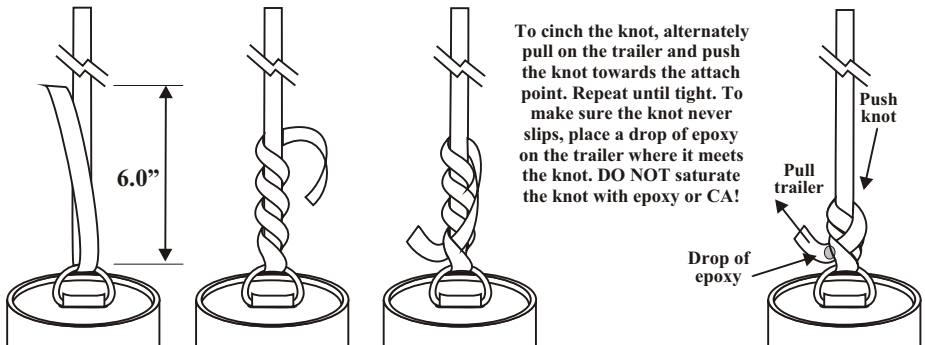

Step 11

The rocket drawn below is generic and may not represent the kit you are building. It is intended to provide a general guideline for mounting launch lugs to this or any rocket.

Sand the entire surface of each launch lug with 100 or 120 grit sandpaper. Epoxy one launch lug in place 1 to 2 inches from the bottom of the rocket and the other launch lug at about the CG (balancing point) of the rocket (without motor installed). If the rocket you are building has a tailcone or boattail, then mount the first lug just above it. Be sure the lugs are perfectly in line with each other, parallel to the airframe and not in line with a fin. Apply an epoxy fillet to both sides of each lug.

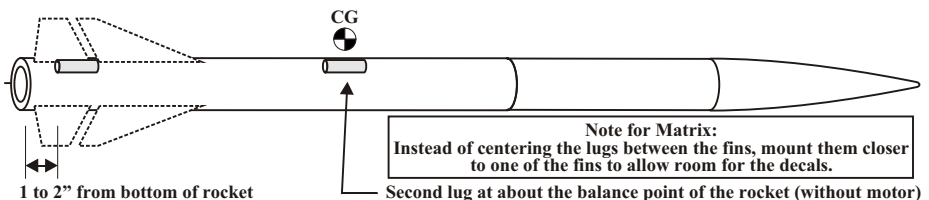

**Decal placement for Matrix kit
repeated three times around
circumference of rocket.
White airframe and nosecone
with black fins and canards.**

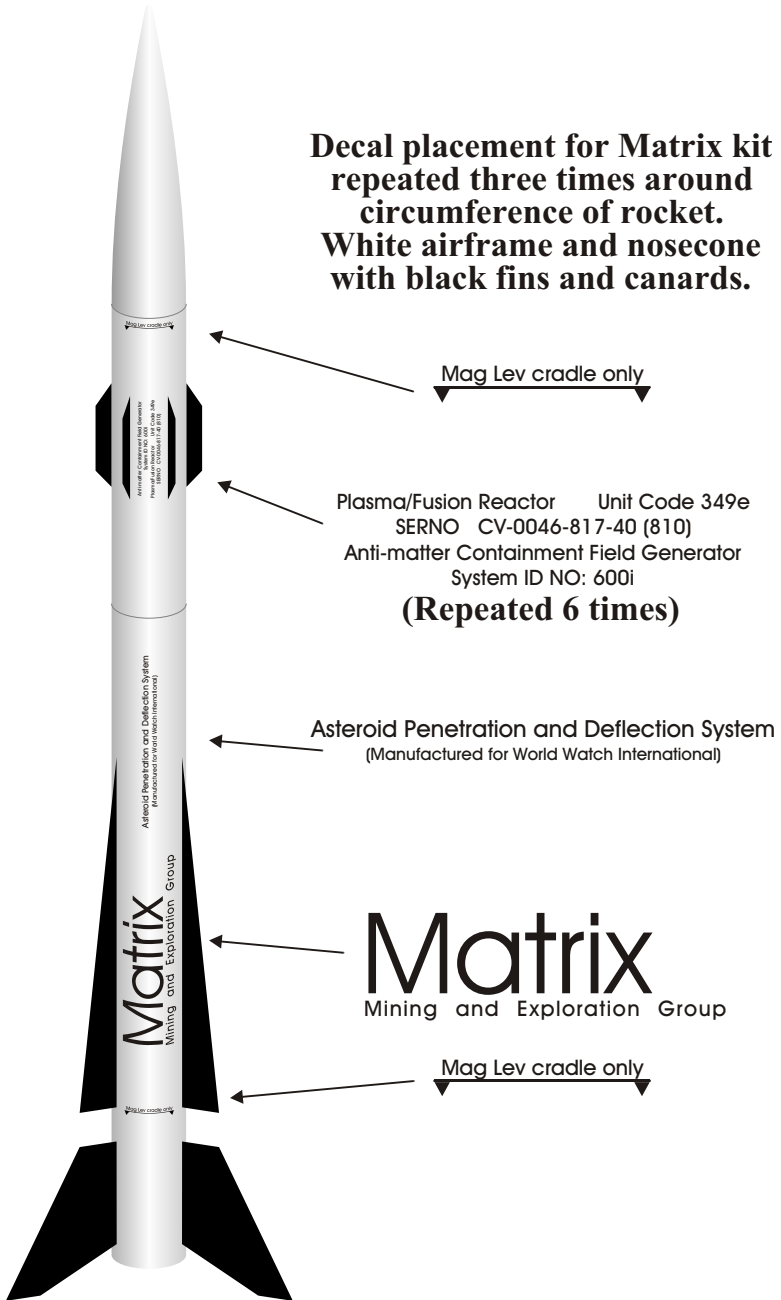

www.publicmissiles.com

The PML Web Store and Knowledge Base

Revised 3.27.00