

AGM-256 Pit Bull

HIGH POWER ROCKET KIT

This kit contains all the parts necessary*
to build a flying high power rocket:

- 1) Pre-slotted main airframe
- 1) Pre-slotted boat tail
- 1) Nose cone
- 4) Main fins
- 4) Canard fins
- 1) Piston ejection kit including:
 - 1) Piston body
 - 1) Piston strap
 - 1) Slotted bulk plate
 - 1) Metal "D" ring
- 1) Parachute
- 1) Motor mount tube (38mm)
- 1) Notched centering ring
- 1) Nylon shock cord
- 1) 1/4" launch lug
- 1) Alignment ring
- 1) Decal sheet
- 1) Instruction sheet (this one!)

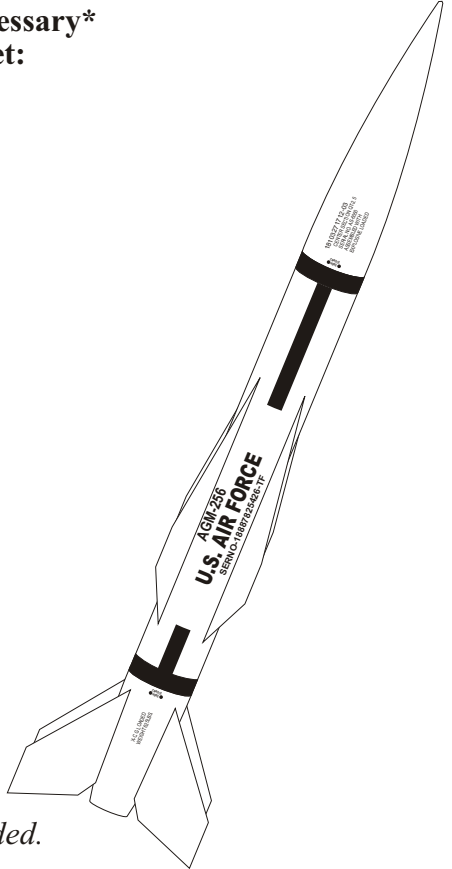

**Epoxy, paint, and motor not included.*

Please read and understand all instructions before building!

The center of pressure (CP) of this rocket is 28.75 inches from nose tip. After finishing your rocket, permanently mark the center of pressure on the airframe. After loading the rocket with a motor, make sure that the center of gravity (balancing point) is at least one body diameter forward of the center of pressure mark. The center of gravity can be moved forward by adding weight to the nose cone.



Basic Construction FAQ

PREP & ASSEMBLY

Read and understand the instruction steps fully before you begin the step.

The manufacturing process of cutting QT may leave the cut end of a tube "squeezed" slightly so that nosecones or pistons seem tight when passing through the end of the tube. Chamfer the inside edge of the tube end via sanding or scraping with a sharp X-Acto knife to prevent this problem.

ALWAYS sand the parts to be bonded with 100-120 grit sandpaper. This includes the area inside the QT where the MMT, fins, couplers, etc. will be bonded. Sandpaper flappers on a drill or sandpaper glued to a dowel work well.

Sand the fin fillet area on each side of the fin slots with 150 grit sandpaper before applying epoxy to the fin and tube.

We strongly recommend you dry-fit (assemble without gluing) all parts in each step BEFORE epoxying them together. Sand or adjust fit as needed before gluing.

Most epoxies work fine. Use 5 or 15 minute depending on how quickly you feel you can complete the step. Use longer set-time epoxy if you're unsure.

To make internal fillets to the fins deep up into the airframe, "load up" the end of a dowel with a blob of epoxy, then stick the dowel into the airframe and onto the fin joint you're working on. After depositing enough epoxy in this fashion, you can pull the dowel toward you, making a fillet with the rounded edge of the dowel.

Fins can be "shaped" or just lightly sand the edges to remove any manufacturing burrs.

PML now advises that CA (cyanoacrylate; "super glue") adhesives CAN be used with QT, though epoxy is recommended.

PAINTING/FINISHING

Before you paint the fins, scuff the entire surface with 220 grit sandpaper. Scuffing is easiest to do before mounting the fins.

Before painting the airframe and nosecone, lightly sand it with 320-400 grit sandpaper.

Do not wipe or spill lacquer thinner or acetone on the Quantum Tube, either will melt and distort the tube. Alcohol or mineral spirits will not damage the QT.

Plastic nosecone imperfections can be filled with plastic model kit putty or automotive spot putty..

Stay with the same brand of paint throughout the process; primer, base color, accent colors, and clear coat. Lacquer, enamel, epoxy and urethane paints have been tested and are compatible with QT tubing. DO NOT skimp on the "shake the can for at least two minutes after the ball rattles" step! For the best finish, let each coat dry overnight and sand lightly with 320 or 400 grit sandpaper.

Apply the last color coat as heavy as possible without running or sagging. Let the paint cure for at least 48 hours before handling!

We recommend a clear coat of some sort to help protect the decals as well as "seal" their edges to help prevent them peeling off. When using any clear coat, put on only VERY thin, light coats, and wait at least 5 minutes between coats. The clear coat can damage your decals or paint if you put it on too heavily or don't wait long enough between coats!

FINAL FITTING/PREPARATIONS FOR FLIGHT

The piston should be a smooth slip-fit in the airframe; this is critical. Sand the piston as needed so it can be easily inserted, and pulled out with just a gentle tug on the shock cord. Keep sandpaper in your range box in case you need to adjust the fit the first few times at the field to deal with differing temperature and humidity. For cold weather flights and other info, see the FAQ Page on our website at www.publicmissiles.com.

Couplers should also be sanded to allow easy separation of the rocket.

If the coupler or nosecone is too loose, use masking tape to build it up to a good fit. If the nosecone is too tight, sand the ribs on the shoulder until it fits well. The parts fit properly if the rocket can be held upside down and gently shaken with nothing moving or coming apart.

Ejections will leave a black, gritty residue inside the airframe. Occasionally wipe the tube interior with a damp cloth wrapped around a dowel or broomstick; allow to dry.

See our website FAQ for information about thrust rings and motor retention. Motor recommendation information is available on our website on the Specs Page.

www.publicmissiles.com

The PML Web Store and Knowledge Base

Other items you will need:

One set of epoxy
One sheet each 120 and 220 sandpaper
Ruler and pencil

Masking tape
PML Expandable Liquid Foam (optional)
Wax paper

**Please read and understand all instructions before continuing!
All surfaces to be bonded must be scuffed with 120 grit sandpaper.**

Step 1

NOTE:

The following step **must** be completed without interruption. Please read and understand this procedure before continuing.

Stand the boat tail upright on a flat surface, preferably on a piece of wax paper. Spread a large bead of epoxy on the bottom end of the motor mount tube as illustrated. Place the motor mount tube into the boat tail and press down to make sure the tube is seated flush with the bottom.

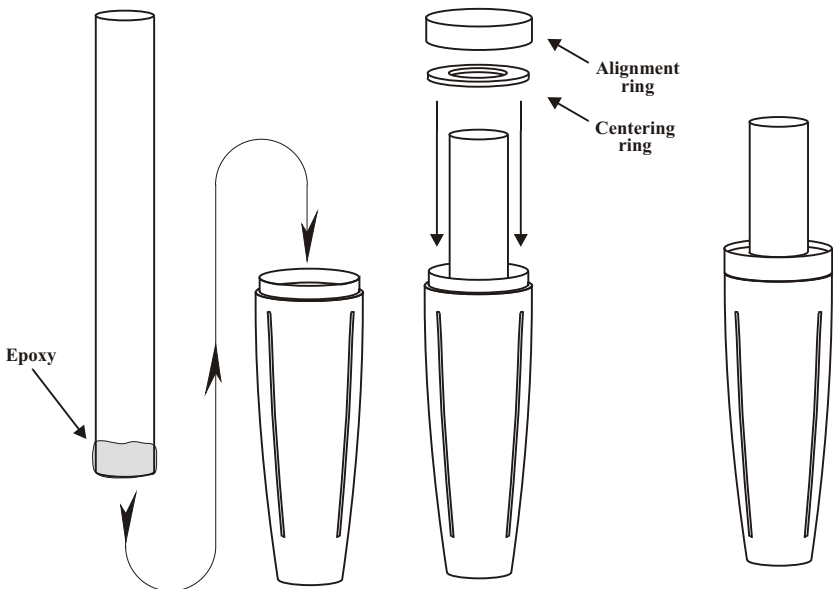

Without using any adhesive, immediately place the centering ring over the top of the motor mount tube and press down firmly until it is in contact with the top of the boat tail. Next slide the alignment ring over the centering ring, again without adhesive, and press until it is seated against the boat tail shoulder. Allow to cure. Keep the centering ring and alignment ring in position while mounting the fins.

Step 2

A) Apply a bead of epoxy to the root edge of a fin. Push the fin through the slot in the airframe and against the motor mount tube. Make sure that the fin is perpendicular to the airframe. Use tape to hold the fin in position while the epoxy cures. Repeat this process for all fins.

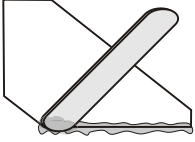

B) Apply an epoxy fillet to both sides of each fin. Carefully smooth the epoxy with your finger before it begins to gel. Allow the epoxy to set up before rotating the rocket to do the next set of fins. Once the epoxy has fully cured, you should sand the fillet smooth with fine sandpaper. Sanding will help the primer hold better to the epoxy.

C) Gently pull the alignment ring and centering ring off the motor tube. Using a stick, apply an epoxy fillet to the fins at the motor mount tube and the inner airframe wall. Though not mandatory, a better method would be to use expandable liquid foam to encapsulate the entire fin root area. See the Liquid Foam instruction sheet for details or visit the Adhesives page of our website at www.publicmissiles.com.

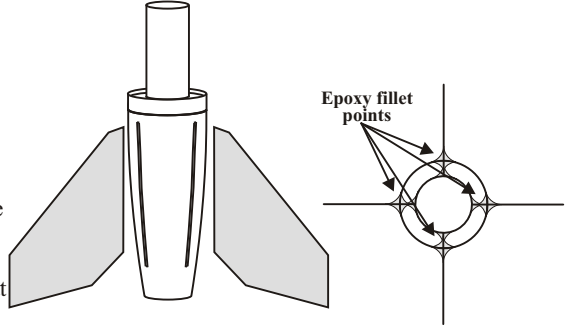

Step 3

Fins not shown for clarity

Remove both the alignment ring and the centering ring. Spread a bead of epoxy around the circumference of the motor tube, 1/2" from the top, leaving a 1" gap in the bead for the notch in the centering ring. Slip the notched centering ring over the motor tube with the notch aligned with the gap in the epoxy bead. Be sure the notch in the ring remains clear of epoxy. Locate the ring 1/2" from the end of the motor tube and allow the epoxy to set. Apply an epoxy fillet to each side of the ring still keeping the notch clear.

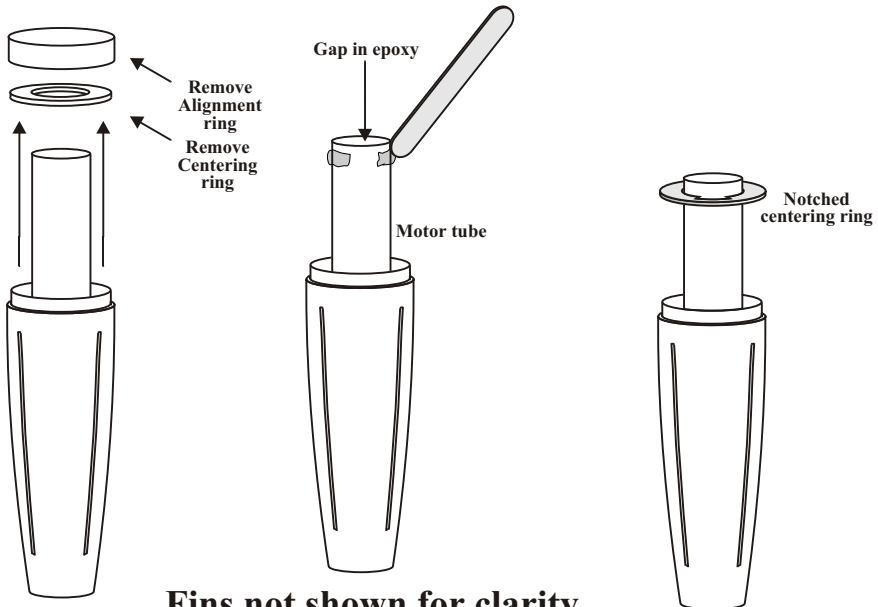

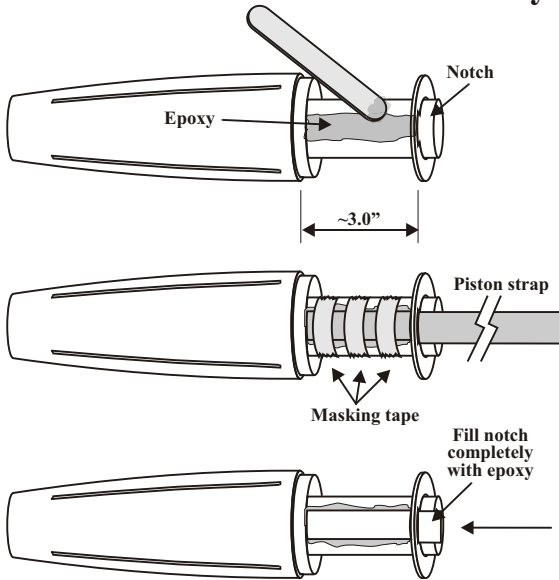
Step 4**Fins not shown for clarity**

Spread a layer of epoxy about 1" wide and 3" long on the motor tube just below the notch in the upper centering ring. Slip one end of the piston strap (the widest strap in the kit) through the notch in the centering ring. Pull through about 3" of this strap through the notch and press it firmly into the epoxy on the side of the motor tube. Hold the strap in place against the tube with masking tape until the epoxy cures. Remove the masking tape. **Fill the entire centering ring notch with epoxy.** Stuff the free end of the strap into the motor tube to keep it out of the way for the next step.

Step 5

1) Apply a bead of epoxy to the root edge of a fin. Push the fin into the dado groove in the airframe. Make sure that the fin is perpendicular to the airframe. Use tape to hold the fin in position while the epoxy cures. Repeat this process for all fins.

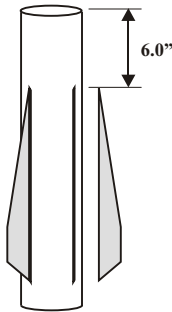

2) Apply an epoxy fillet to both sides of each fin. Carefully smooth the epoxy with your finger before it begins to gel. Allow the epoxy to set-up before rotating the rocket to do the next set of fins. Once the epoxy has fully cured, you should sand the fillet smooth with 220 grit sandpaper. Sanding will help the primer hold better to the epoxy.

Step 6

Apply a heavy layer of epoxy to the inside circumference of the main airframe at the bottom end and another 2" in from the bottom. Tip the tail section into the main airframe as shown to get the centering ring past the first ring of epoxy then straighten it as you continue to push it into the airframe. Align the upper and lower fins. Stand the assembly upright and allow the epoxy to cure.

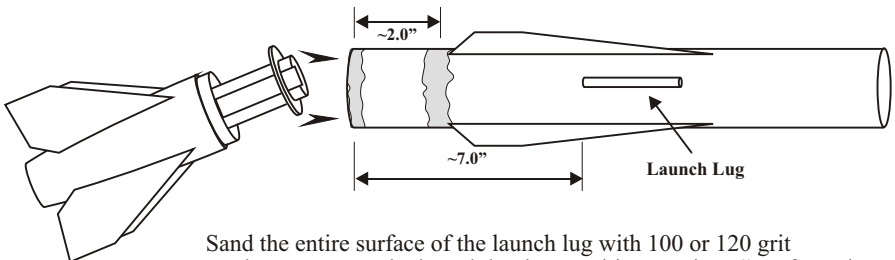

Sand the entire surface of the launch lug with 100 or 120 grit sandpaper. Epoxy the launch lug into position starting 7" up from the bottom of the main airframe. Be sure the lug is not in line with the fins and is parallel to the airframe.

Step 7

NOTE: In this step you will be using the free end of the strap that you mounted to the motor tube assembly.

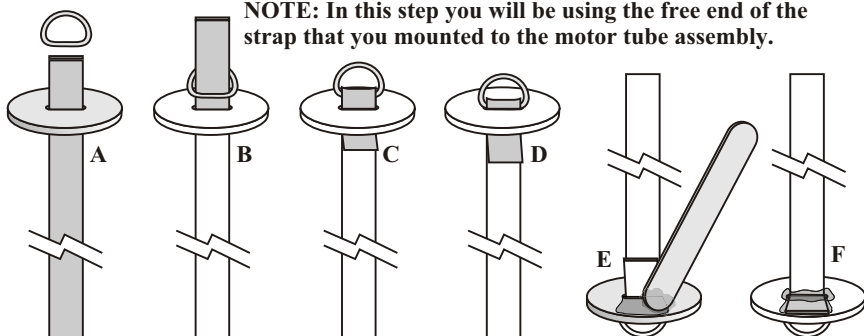

A) Pull the free end of the strap through the slot in the piston bulk plate.

B) Slip the metal "D" ring over the strap.

C) Feed the strap back through the slot.

D) Pull on the strap until the "D" ring is wedged at the slot.

E) Flip the assembly over. Spread a layer of epoxy on the underside of the piston plate as shown. Fold the short end of the strap flat against the piston plate and press it into the epoxy. You can use a clamp to hold the strap in the epoxy while it sets.

F) When the epoxy has cured, pull the strap until the "D" ring is wedged tight at the slot. Apply epoxy to the strap at the "D" ring.

G) Epoxy the piston plate inside the piston body 1/8" from the top.

H) Apply an epoxy fillet to both sides of the piston plate.

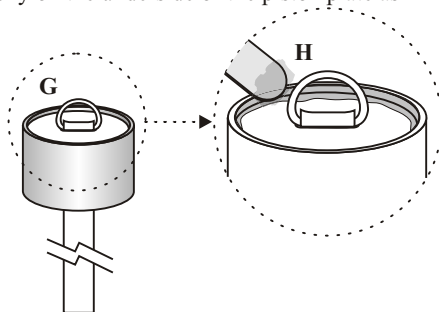

Step 8

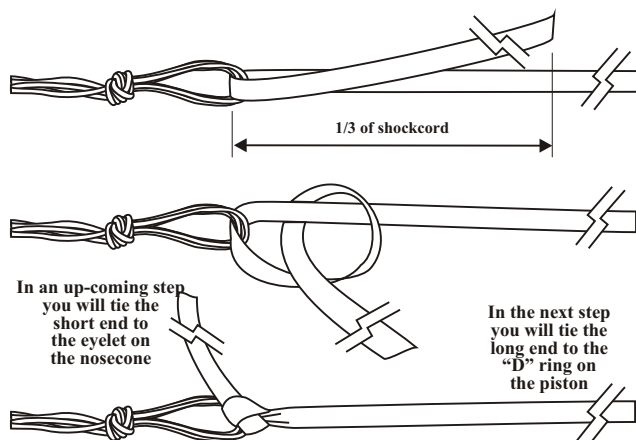

Prepare the parachute per the parachute instructions. Thread the shock cord through the loop you made in the parachute shroud lines and tie it using the knot illustrated on the left. Note that the chute should be attached to the shock cord at about the 1/3 point of the shock cord. Alternatively, you can tie the shock cord to a "kwik-link" and then attach the "kwik-link" to the loop in the shroud lines.

In an up-coming step you will tie the short end to the eyelet on the nosecone

In the next step you will tie the long end to the "D" ring on the piston

Step 9

Thread the long end of the shock cord through the “D” ring and tie it using the knot illustrated below. Alternatively, you can tie the shock cord to a “kwik-link” and then attach the “kwik-link” to the “D” ring.

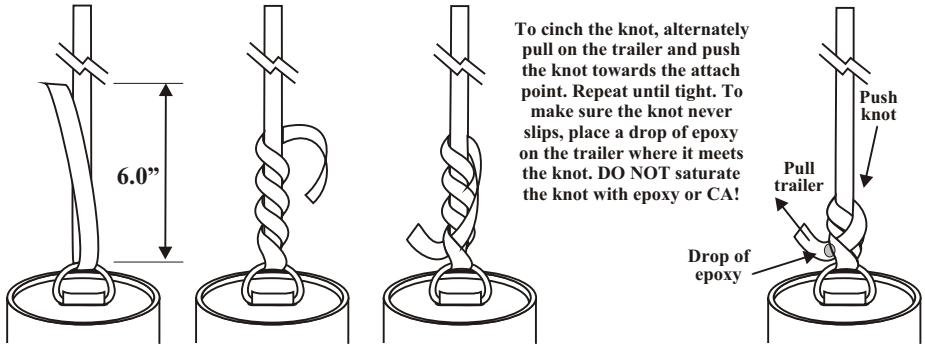

Step 10

Using a sharp pointed knife, remove the flash from the eyelet at the base of the nosecone. If necessary, you can enlarge the eyelet by using the knife to extend the opening toward the nosecone body (not toward the edges as this will weaken the eyelet). Thread the shock cord through the eyelet and tie it to the nosecone using the knot illustrated below. Add a drop of epoxy to the trailer at the knot to make sure the knot never slips. **DO NOT** saturate the knot with epoxy or CA. Alternatively, you can tie the shock cord to a “kwik-link” and then attach the “kwik-link” to the nosecone eyelet.

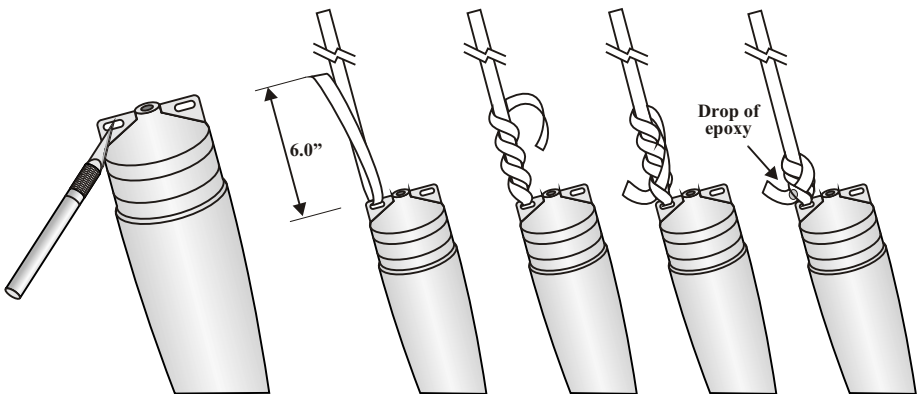

When fitting the nosecone to the top of the airframe, it should be just tight enough to allow you to lift the entire rocket by the tip without the nosecone sliding off the rocket. If the fit seems too tight, very lightly sand the two ridges on the nosecone shoulder. If the fit seem too loose, apply small lengths of masking tape to the nosecone shoulder.

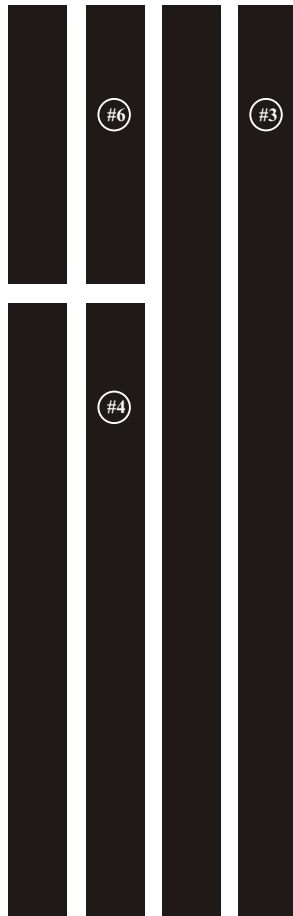
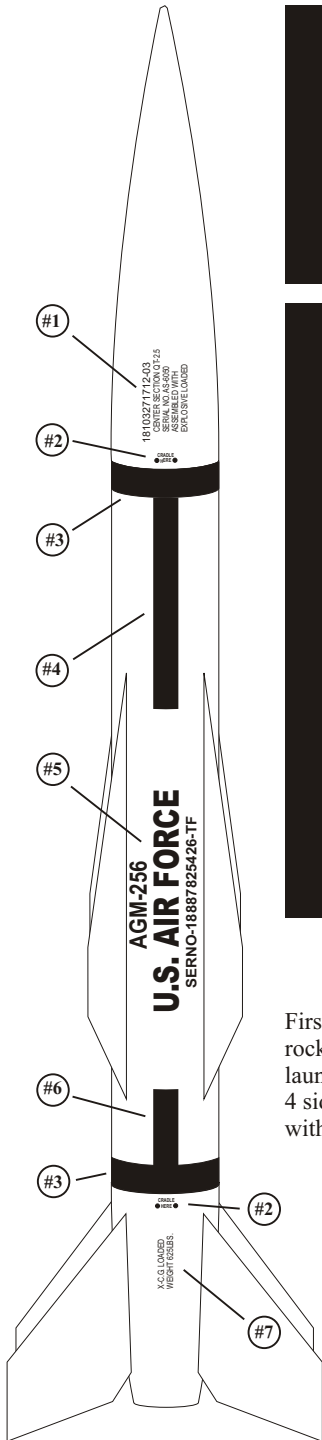

First paint the entire rocket white. Two opposite sides of the rocket are identical. Decals as shown are 90 degrees from the launch lug side of the rocket. Decals #2 and #7 are located on all 4 sides of the rocket. Decals #3 are on the airframe tube flush with the tube ends.

AGM-256
U.S. AIR FORCE
 SERNO-18887825426-TF

AGM-256
U.S. AIR FORCE
 SERNO-18887825426-TF

X-C.G. LOADED
 WEIGHT 625LBS.
 X-C.G. LOADED
 WEIGHT 625LBS.
 X-C.G. LOADED
 WEIGHT 625LBS.
 X-C.G. LOADED
 WEIGHT 625LBS.

18103271712-03
 CENTER SECTION QT-2.5
 SERIAL NO. AS-6050
 ASSEMBLED WITH
 EXPLOSIVE LOADED

18103271712-03
 CENTER SECTION QT-2.5
 SERIAL NO. AS-6050
 ASSEMBLED WITH
 EXPLOSIVE LOADED



CRADLE ● HERE ●
 CRADLE ● HERE ●
 CRADLE ● HERE ●
 CRADLE ● HERE ●
 CRADLE ● HERE ●
 CRADLE ● HERE ●



www.publicmissiles.com

The PML Web Store and Knowledge Base

Revised 4.24.06