



extreme

www.spa-uk.co.uk tel. +44 (0) 1543 434580



extreme

www.spa-uk.co.uk tel. +44 (0) 1543 434580

Models covered SPAEX2.0-M SPAEX2.25-M ~ EB37J%Z Z

INSTALLATION INSTRUCTIONS

FIA Homologation EX.039.16, EX.049.18 & EX.053.18

Please read carefully before attempting to install your fire suppression system.

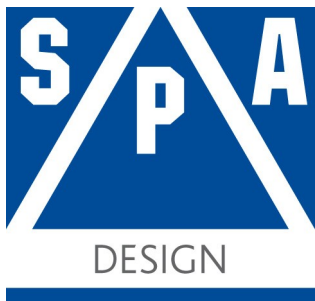

The Mill House, Tamworth Road, Packington Hayes
Nr Lichfield, Staffordshire, England, WS14 9PN
Tel: 01543 434580 Fax: 01543 434581
Email: sales@spa-uk.co.uk
Website: www.spa-uk.co.uk



Mechanical 2kg, 2.25kg & 3kg Novec 1230 Systems



Thank you for purchasing one of our latest range of FIA Homologated fire suppression systems.

This manual covers the following model systems SPAEX2.0-M, SPAEX2.25-M & SPAEX3.0-M.

It is important that you read the following instructions carefully before attempting to install your fire suppression system.

The performance of these systems could be affected if they are in any way modified or tampered with and will void its homologation. Please ensure you only use genuine SPA parts should any part need replacing. Should you require assistance with this please call +44(0)1543 434580

Index	Pages
System Contents	1 – 2
Engine Bay / Cockpit Nozzle Location	3 – 6
Lever Valve Assembly	9
Mechanical System Fitting Instructions	10
Tubing Maintenance	11
Suppression Data Sheet	12

CONTENTS LIST

MODEL SPAEX2.0-M & SPAEX3.0-M 2.0 – 3.0 KG Mechanical NOVEC FIRE SUPPRESSION SYSTEM

- 1 x SPAEX2.0-M-B - 2.0 KG Novec Mechanical Cylinder Only. (SPAEX2.0-M Only)
- 1 x SPAEX3.0-M-B - 3.0 KG Novec Mechanical Cylinder Only. (SPAEX3.0-M Only)
- 1 x SP147 – 5” Diameter Retaining Straps x 2. (SPAEX2.0-M Only)
- 1 x SP143 – 6” Diameter Retaining Straps x 2. (SPAEX3.0-M Only)

All Models

- 1 x SP319 – Anti Torpedo Tabs x 2.
- 4.5 x SP016 – 6mm Decabon Tubing Per Meter.
- 2.5 x SP032 – 8mm Decabon Tubing Per Meter.
- 1 x SP072 – 10mm Decabon Tubing Per Meter.
- 0.5 x SP181 – 10mm Decabon Tubing Per Meter.
- 1 x SP182 – 12mm – 10mm Y Piece Connector.
- 1 x SP183 – 10mm – 8mm Y Piece Connector.
- 1 x SP184 – 8mm – 6mm Y Piece Connector.
- 1 x SP186 – 10mm – 8mm Straight Reducer Connector.
- 1 x SP185 – 10mm Bulkhead Connector.
- 2 x SP187 – 8mm Engine Bay Nozzle.
- 2 x SP188 – 6mm Cockpit Bay Nozzle.
- 1 x SP018 – 6 Foot Pull Cable.
- 1 x SP019 – 12 Foot Pull Cable.
- 2 x SP108 – Pull Cable Adjuster.
- 2 x SP110 – Pull Cable Solderless Clamp
- 1 x SP017 – Large E Location Sticker.
- 1 x SP029 – Small E Location Sticker

CONTENTS LIST

MODEL SPAEX2.25-M 2.25 Mechanical NOVEC FIRE SUPPRESSION SYSTEM

- 1 x SPAEX2.25-M-B - 2.25 KG Novec Mechanical Cylinder Only.
- 1 x SP147 – 5” Diameter Retaining Straps x 2.
- 1 x SP319 – Anti Torpedo Tabs x 2.
- 4.5 x SP032 – 8mm Decabon Tubing Per Meter.
- 2.5 x SP072 – 10mm Decabon Tubing Per Meter.
- 0.5 x SP181 – 12mm Decabon Tubing Per Meter.
- 1 x SP182 – 12mm – 10mm Y Piece Connector.
- 1 x SP183 – 10mm – 8mm Y Piece Connector.
- 1 x SP186 – 10mm – 8mm Straight Reducer Connector.
- 1 x SP185 – 10mm Bulkhead Connector.
- 2 x SP187 – 8mm Engine Bay Nozzle.
- 1 x SP481 - 8mm Cockpit Deflector Nozzle.
- 1 x SP018 – 6 Foot Pull Cable.
- 1 x SP019 – 12 Foot Pull Cable.
- 2 x SP108 – Pull Cable Adjuster.
- 2 x SP110 – Pull Cable Solderless Clamp
- 1 x SP017 – Large E Location Sticker.
- 1 x SP029 – Small E Location Sticker

COCKPIT NOZZLE LOCATION FOR SALOON CARS & SPORTS CARS

SPAEX2.0-M & SPAEX3.0-M

Two nozzles should be mounted in the cockpit area of a saloon car, we recommend that these are mounted under the dashboard spraying horizontally across the drivers foot-well and co-drivers compartment.

SALOON & SPORTS CAR NOZZLE POSITIONS

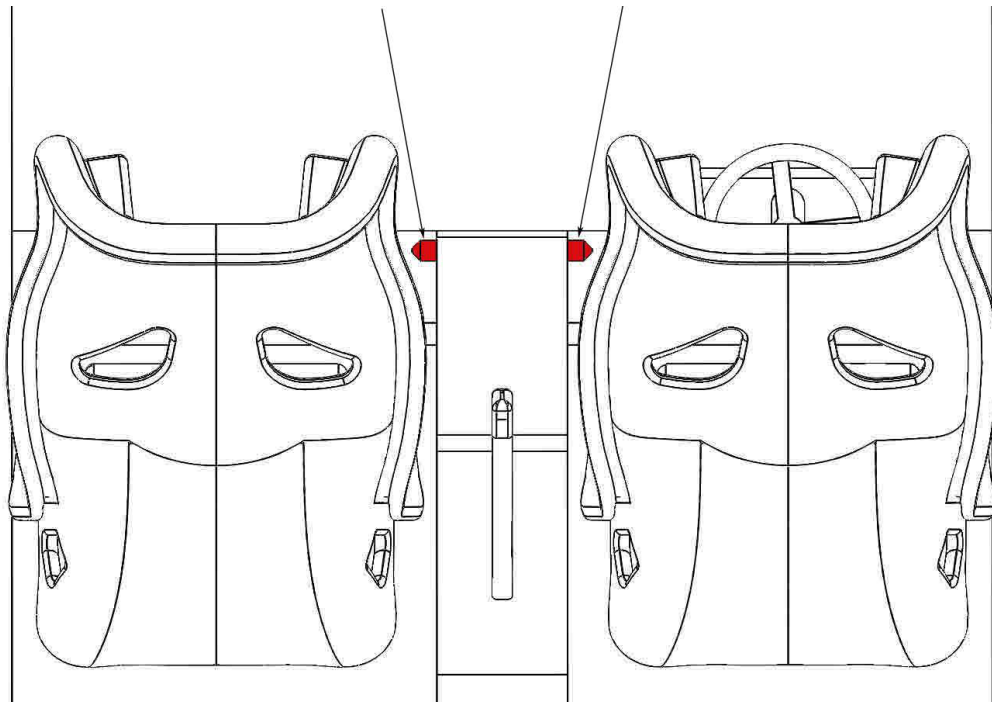

COCKPIT NOZZLE LOCATION FOR SINGLE SEATERS

SPAEX2.25-M

The SP481 Cockpit nozzle is specially engineered as a fully multi-directional nozzle, this allows you to position the nozzle as shown in figure 1 or figure 2 which will cover the driver and foot-well position.

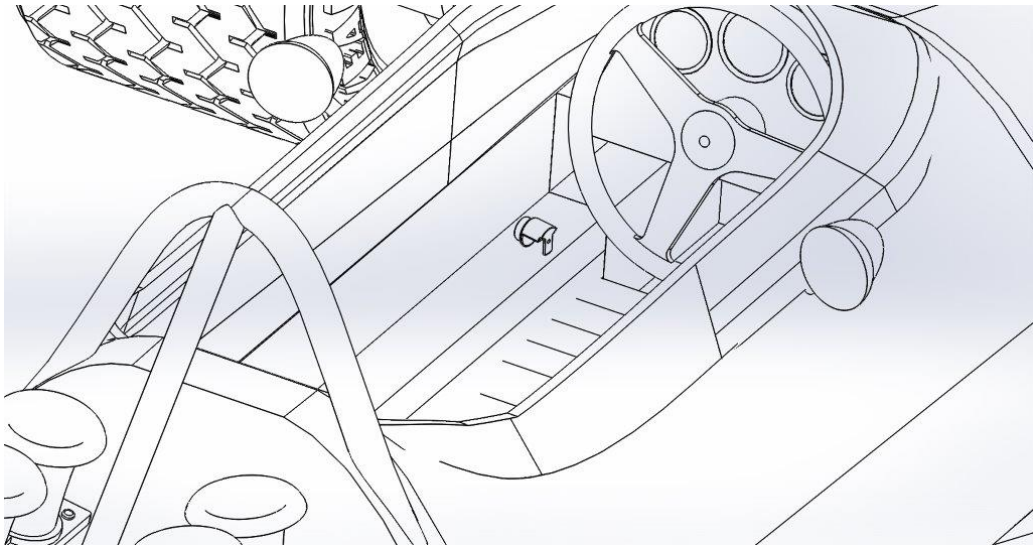

Fig 1

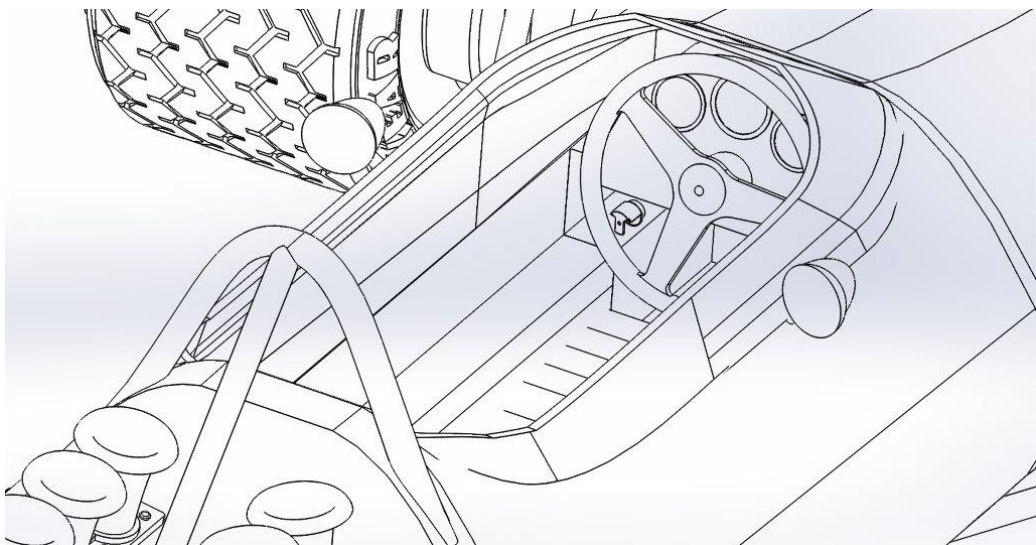
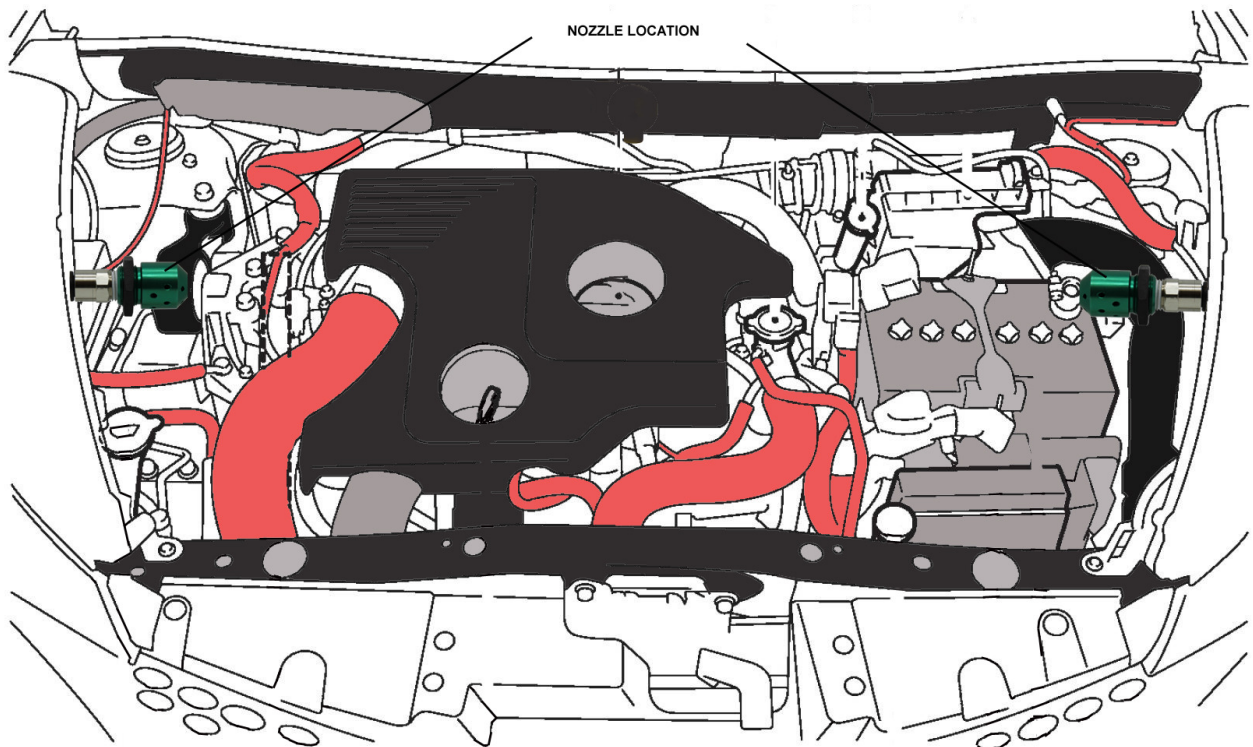

Fig 2

ENGINE BAY NOZZLE LOCATION

Two nozzles should be mounted in Engine compartment fig
1 All models



TUBING

Each SPA Extreme system is supplied with Decabon tubing which is a coated aluminium tube which can be molded and flexed to suit this application. The SPA Extreme system has been designed using this type of tube.
DO NOT substitute this tube for any other type.

MULTI-DIRECTIONAL NOZZLES

Please note that nozzle shown in Fig.A must only be used in engine bay.
Nozzle shown in Fig.B must only be used in cockpit.

fig A

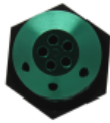

fig B



It is important that the correct nozzles supplied with the system are used, the nozzles produce a multi directional spray pattern and must be positioned as shown in Fig A.

fig A



Yes

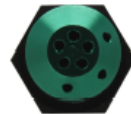

No

Cockpit Nozzle orientation for system model SPAEX2.25-M



Yes

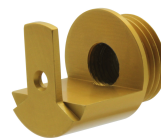

No

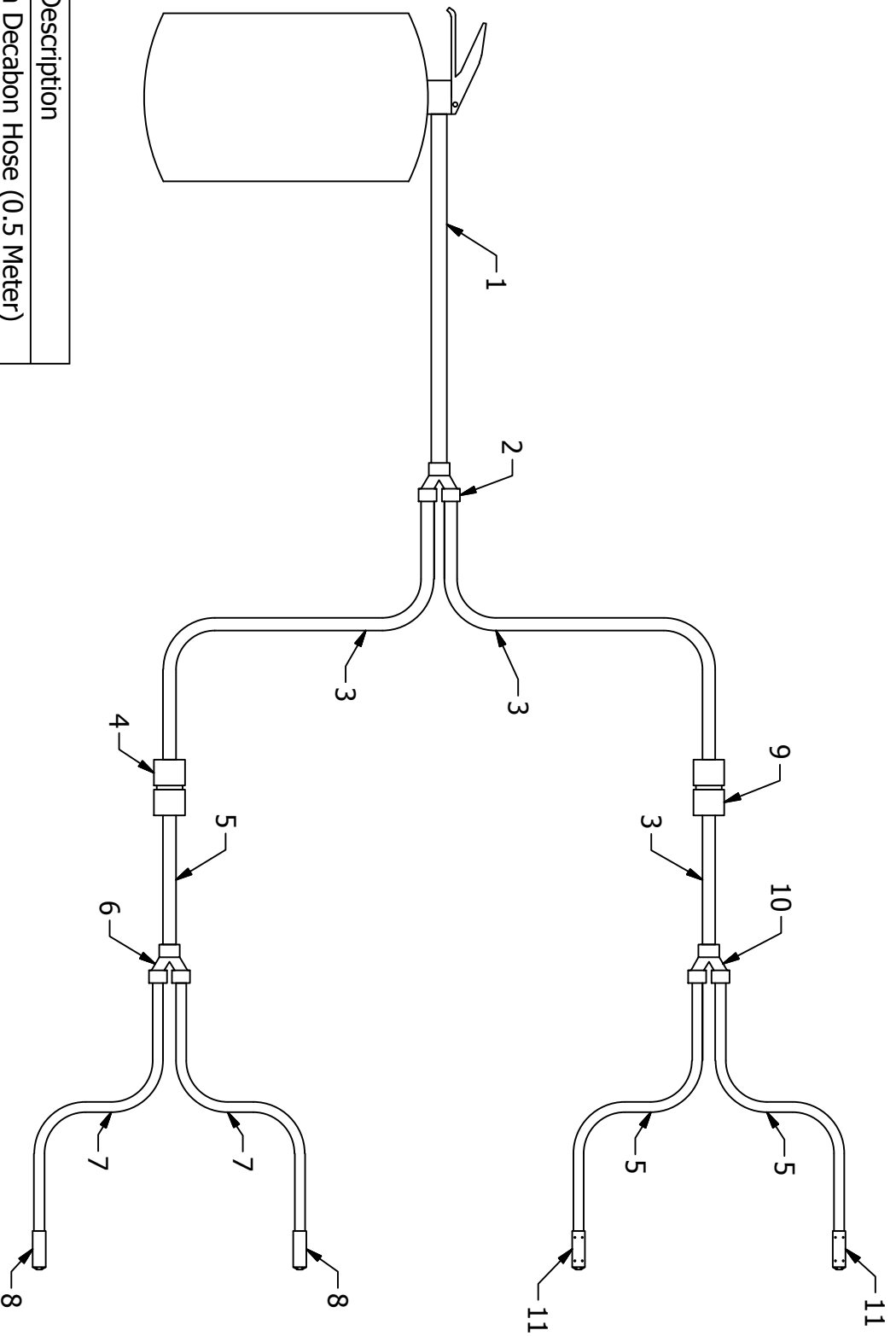
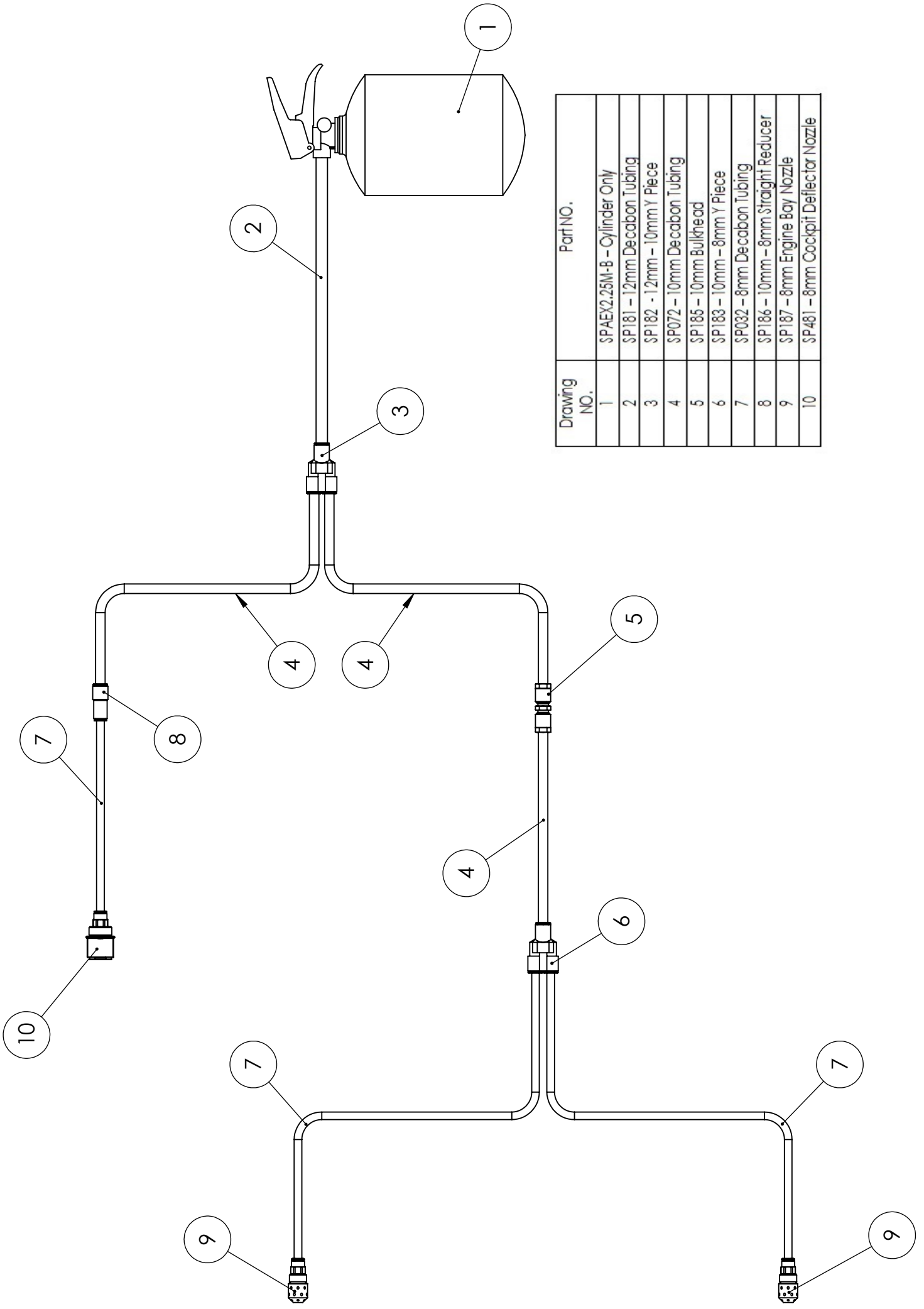

Fig 2

Part Description	
1	SP181 - 12mm Decarbon Hose (0.5 Meter)
2	SP182 - 12mm-10mm Y-Piece
3	SP072 - 10mm Decarbon Hose (1 Meter)
4	SP186 - 10mm-8mm Reducer
5	SP032 - 8mm Decarbon Hose (2.5 Meters)
6	SP184 - 8mm-6mm Y-Piece
7	SP016 - 6mm Decarbon Hose (4.5 Meters)
8	SP188 - Cockpit Nozzle
9	SP185 - 10mm Bulkhead Fitting
10	SP183 - 10mm-8mm Y-Piece
11	SP187 - Engine Bay Nozzle



Drawing NO.	Part NO.
1	SPAEX2.25M-B - Cylinder Only
2	SP181 - 12mm Decabon Tubing
3	SP182 - 12mm - 10mm Y Piece
4	SP072 - 10mm Decabon Tubing
5	SP185 - 10mm Bulkhead
6	SP183 - 10mm - 8mm Y Piece
7	SP032 - 8mm Decabon Tubing
8	SP186 - 10mm - 8mm Straight Reducer
9	SP187 - 8mm Engine Bay Nozzle
10	SP481 - 8mm Cockpit Deflector Nozzle

LEVER VALVE ATTACHMENTS

Fig 3

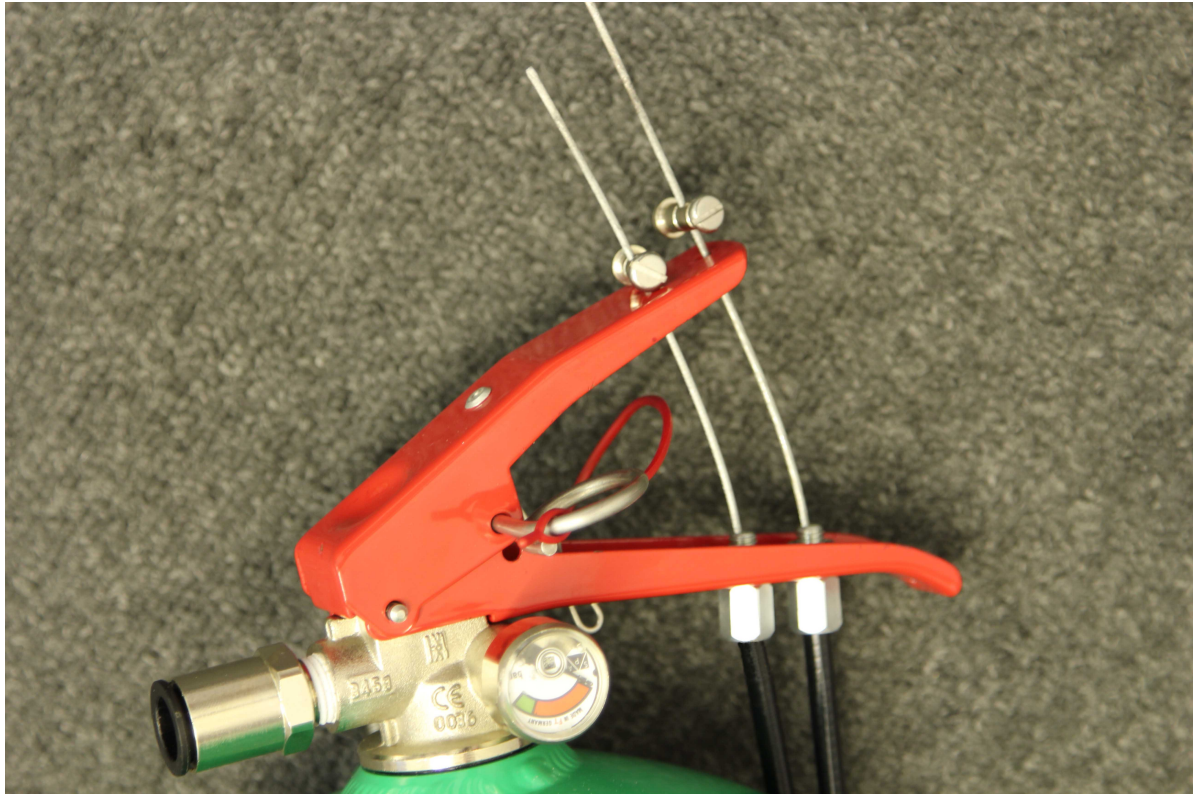

CABLE ATTACHMENT

2 x SP108 – Pull Cable Adjuster.

2 x SP110 – Pull Cable Solderless Clamp

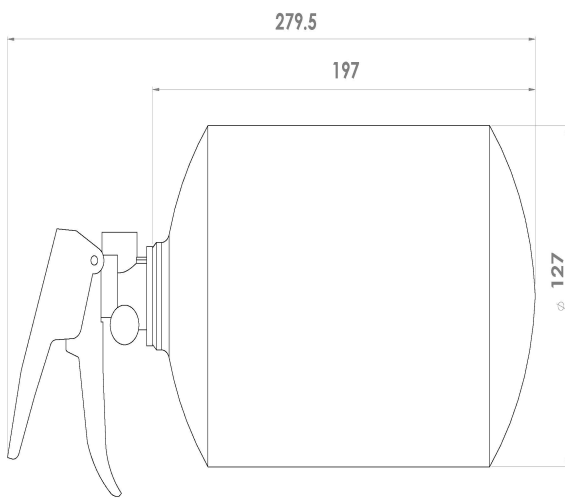

SPAEX2.25-M

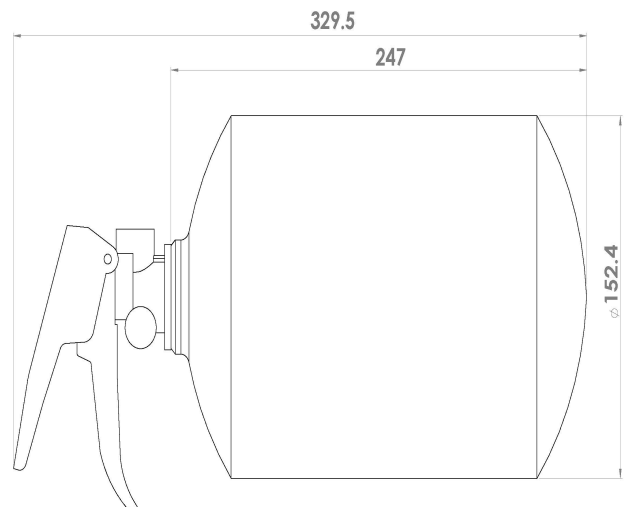

SPAEX3.0-M

MECHANICAL SYSTEM FITTING INSTRUCTIONS

This SPA Extreme system is mechanically operated, it uses two T handle pull cables one at 6 feet and one at 12 feet in length. Please read carefully the below instructions.

Unpack all parts and check against contents list page

Decide the best position for the extinguisher system - it is recommended that the bottle be mounted in the fore and aft direction of the vehicle.

It is important that the contents label and pressure gauge are clearly visible for scrutineering.

Mount the bottle securely in the retaining brackets and anti-torpedo tabs

Insert the tubing into the push-in fitting on the lever valve and lay the end of the tube from the cylinder to the chosen location for the nozzle, push the nozzle onto the tubing and orientate this to point the nozzle in the direction of the anticipated fire source.

Make sure the safety pin is in place at all times during assembly.

When installing cables it is important there are no kinks in the cable and no 'S' bends formed which may cause malfunction.

Mount the 6 foot cable in the cockpit within easy reach of the driver when sitting in the seat wearing the safety harnesses - the other end of the cable is to be threaded through one of the adjusting screws on the handle of the lever valve on the cylinder. **Fig 3**

Once this is inserted through the clamp it is important to not have more than 6mm of play in the cable where it has been clamped.

Mount the 12 foot cable on the outside of the vehicle, (close to the exterior master switch is the recommended position).

Lay the cable in the vehicle and connect to the lever valve as shown in **Fig 3**

Remove the safety pin from the lever valve only when ready to use, replace when not in use.

TUBING

Each SPA Extreme system kit is supplied with Decabon tubing which is a coated aluminium tube which can be molded and flexed to suit this application. The SPA Extreme system has been designed and homologated using this type of tube.

DO NOT substitute this tube for any other type.

TUBE CONNECTIONS

All fittings for tube to nozzles and bottles are of the push-in type. Insert the tube into the fitting, push firmly until it clicks. Once in you should not be able to pull it out. To remove the tubing, push the tube into the fitting and at the same time push the black plastic collet back towards the fitting and then pull the tube from the fitting.

MAINTENANCE

To ensure maximum possible performance from your SPA Extreme system, the following checks and maintenance procedures should be carried out.

Regularly check Nozzles for debris or any obstructions externally or internally.

Regularly check the integrity of the pipe work and fitting.

Regularly check the cylinder for damage or corrosion.

Regularly check the mounting bracket, retaining straps and anti torpedo tabs are secure.

Your SPA fire suppression system must be serviced every 2 years, a service due date is written on the contents label located on your cylinder. It is up to you to ensure the services are carried out at the correct intervals.

If your system has been discharged or requires a 2 year service you must return it to SPA or an service agent approved by SPA for it to be FIA certified for continued use.

NOTES

Please ensure that you monitor the following as you may not pass scrutineering if The bottle contents label is worn, damaged or unreadable.

The system is not within service date.

The system is in poor condition.

EXTREME DATA SHEET

Application	Auto-sport industry - including saloon race cars & single seaters.
Composition	Dodecafluoro-2-methylpentan-3-one <chem>CF3CF2C(O)CF(CF3)2</chem>
Ozone depletion potential	None
Operating temperature	- 40 to + 80-C
Freezing point	-108-C
Critical temperature	168.7 °C
Physiological properties	No observed adverse effect level and lowest observed adverse effect level for cardiac sensitization (halocarbon) and oxygen depletion (Inert gas).

A copy of the 3M™Novec™ 1230 fire protection fluid material safety data sheet can be obtained from SPA Design or SPA Technique upon request.

NOTES



extreme

www.spa-uk.co.uk tel. +44 (0) 1543 434580



The Mill House, Tamworth Road, Packington Hayes
Nr Lichfield, Staffordshire, England, WS14 9PN
Tel: 01543 434580 Fax: 01543 434581
Email: sales@spa-uk.co.uk
Website: www.spa-uk.co.uk

