

## INDUCTION MOTOR

**90W**

**□90mm** LEAD WIRE TYPE  
TERMINAL BOX TYPE

K9IS90F□



K9IS90F□-T, T5



### SPECIFICATIONS

90W 연속정격, 4극

Model	Voltage (V)	Frequency (Hz)	Current (A)	Start T. (N·m/kgf·cm)	Rated T. (N·m/kgf·cm)	Speed (rpm)	Condenser (μF)
K9I□90FJ(-T, -T5)	100	50	2.07	0.55/5.5	0.675/6.75	1300	30
		60	1.97		0.55/5.5	1600	
K9I□90FU(-T, -T5)	110	60	1.47	0.44/4.4	0.55/5.5	1600	20
	115		1.52				
K9I□90FL(-T, -T5)	200	50	0.75	0.5/5	0.675/6.75	1300	7
		60	0.97		0.57/5.7	1550	
K9I□90FC(-T, -T5)	220	50	0.8	0.45/4.5	0.675/6.75	1300	6
		60	0.9	0.5/5	0.57/5.7	1550	
	230	50	0.87	0.55/5.5	0.675/6.75	1300	
		60	0.93		0.57/5.7	1550	
K9I□90FD(-T, -T5)	240	50	0.85	0.5/5	0.675/6.75	1300	5
K9I□90FT(-T, -T5)	200	50	0.79	2.25/22.5	0.65/6.5	1350	-
		60	0.72	1.75/17.5	0.55/5.5	1600	
K9I□90FH(-T, -T5)	220	50	0.72	2.35/23.5	0.65/6.5	1350	-
		60	0.63	1.8/18	0.55/5.5	1600	
	230	50	0.86	2.45/24.5	0.65/6.5	1350	
		60	0.66	1.95/19.5	0.55/5.5	1600	
K9I□90FM(-T, -T5)	380	50	0.43	2.35/23.5	0.65/6.5	1350	-
		60	0.37	1.7/17	0.55/5.5	1600	
K9I□90FV(-T, -T5)	400	50	0.52	2.65/26.5	0.65/6.5	1350	-
		60	0.45	2.1/21	0.55/5.5	1600	
K9I□90FQ(-T, -T5)	415	50	0.39	2/20	0.68/6.8	1300	-
		60	0.31	1.5/15	0.55/5.5	1600	
K9I□90FZ(-T, -T5)	440	50	0.45	2.1/21	0.68/6.8	1300	-
		60	0.39	1.7/17	0.55/5.5	1600	

\* □ : SHAFT 형상 ( S : STRAIGHT, P : PINION ) \* 기종 명 끝에 FU, FC, FH, FH-T, FH-T5 품번은 UL규격 인증 제품입니다. UL FILE NO. E204632  
\* 삼상 380V이상 사양의 MOTOR는 INVERTER와의 조합에서는 사용 할 수 없습니다. MOTOR 권선의 절연이 열화되어 파손될 가능성이 있습니다.

### RATED TORQUE OF GEARHEAD

#### ● 50Hz

단위 = 상단 : N·m / 하단 : kgf·cm

Model Motor/ Gearhead	Speed(rpm)	500	416	300	250	200	166	150	120	100	83	75	60	50	41	37	30	25	20	16	15	12.5	10	8.3	7.5
	Ratio	3	3.6	5	6	7.5	9	10	12.5	15	18	20	25	30	36	40	50	60	75	90	100	120	150	180	200
K9I□90F□(-T, -T5) K9P□B, BF	1.58	1.90	2.63	3.16	3.95	4.74	5.27	5.92	7.11	8.53	9.48	10.66	12.79	15.35	17.06	20	20	20	20	20	20	20	20	20	20
	15.8	19.0	26.3	31.6	39.5	47.4	52.7	59.2	71.1	85.3	94.8	106.6	127.9	153.5	170.6	200	200	200	200	200	200	200	200	200	200

#### ● 60Hz

단위 = 상단 : N·m / 하단 : kgf·cm

Model Motor/ Gearhead	Speed(rpm)	600	500	360	300	240	200	180	144	120	100	90	72	60	50	45	36	30	24	20	18	15	12	10	9
	Ratio	3	3.6	5	6	7.5	9	10	12.5	15	18	20	25	30	36	40	50	60	75	90	100	120	150	180	200
K9I□90F□(-T, -T5) K9P□B, BF	1.34	1.60	2.23	2.67	3.34	4.01	4.46	5.01	6.01	7.22	8.02	9.02	10.83	12.99	14.43	18.04	20	20	20	20	20	20	20	20	20
	13.4	16.0	22.3	26.7	33.4	40.1	44.6	50.1	60.1	72.2	80.2	90.2	108.3	129.9	144.3	180.4	200	200	200	200	200	200	200	200	200

- \* GEARHEAD-DECIMAL GEARHEAD는 별매입니다.
- \* GEARHEAD의 품명중 □에는 감속비가 들어갑니다.
- \*   색이 MOTOR와 같은 방향, 그 외에는 반대 방향입니다.
- \* 표의 감속비보다 더 감속하고자 할 경우는 GEARHEAD와 MOTOR 사이에 감속비 10의 DECIMAL GEARHEAD를 설치할 수 있습니다. 이 경우의 허용 TORQUE는 20 N·m / 200 kgf·cm 입니다.
- \* 회전수는 MOTOR의 동기 회전수 (50 Hz : 1500 rpm, 60 Hz : 1800 rpm)를 기준으로 하여 감속비로 나누어서 계산하였습니다. 실제의 회전수는 부하의 크기에 따라서 표시된 수치보다 2~20% 적습니다.

## GEARHEAD

### RATED TORQUE OF GEARHEAD

#### ● 50Hz

단위 = 상단 : N·m / 하단 : kgf·cm

Model Motor/ Gearhead	Speed(rpm)	500	416	300	250	200	166	150	120	100	83	75	60	50	41	37	30	25	20	16	15	12,5	10	8,3	7,5
	Ratio	3	3,6	5	6	7,5	9	10	12,5	15	18	20	25	30	36	40	50	60	75	90	100	120	150	180	200
K9I□90F□(-T, T5) K9P□BU, BUF		1,58	1,90	2,63	3,16	3,95	4,74	5,27	5,92	7,11	8,53	9,48	10,66	12,79	15,35	17,06	21,32	25,59	30	30	30	30	30	30	30
		15,8	19,0	26,3	31,6	39,5	47,4	52,7	59,2	71,1	85,3	94,8	106,6	127,9	153,5	170,6	213,2	255,9	300	300	300	300	300	300	300

#### ● 60Hz

단위 = 상단 : N·m / 하단 : kgf·cm

Model Motor/ Gearhead	Speed(rpm)	600	500	360	300	240	200	180	144	120	100	90	72	60	50	45	36	30	24	20	18	15	12	10	9
	Ratio	3	3,6	5	6	7,5	9	10	12,5	15	18	20	25	30	36	40	50	60	75	90	100	120	150	180	200
K9I□90F□(-T, T5) K9P□BU, BUF		1,34	1,60	2,23	2,67	3,34	4,01	4,46	5,01	6,01	7,22	8,02	9,02	10,83	12,99	14,43	18,04	21,65	24,36	29,23	30	30	30	30	30
		13,4	16,0	22,3	26,7	33,4	40,1	44,6	50,1	60,1	72,2	80,2	90,2	108,3	129,9	144,3	180,4	216,5	243,6	292,3	300	300	300	300	300

- \* GEARHEAD·DECIMAL GEARHEAD는 별매입니다.
- \* GEARHEAD의 품명중 □에는 감속비가 들어갑니다.
- \* ■ 색이 MOTOR와 같은 방향, 그 외에는 반대 방향입니다.
- \* 표의 감속비보다 더 감속하고자 할 경우는 GEARHEAD와 MOTOR 사이에 감속비 10의 DECIMAL GEARHEAD를 설치할 수 있습니다. 이 경우의 허용 TORQUE는 30 N·m / 300 kgf·cm 입니다.
- \* 회전수는 MOTOR의 동기 회전수 (50 Hz : 1500 rpm, 60 Hz : 1800 rpm)를 기준으로 하여 감속비로 나누어서 계산하였습니다. 실제의 회전수는 부하의 크기에 따라서 표시된 수치보다 2~20% 적습니다.

### DIMENSIONS

K9IS90F□

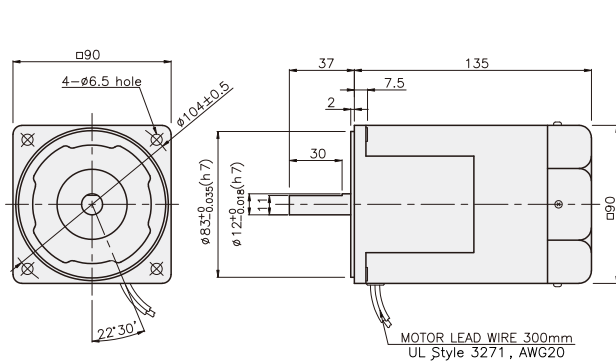

K9IS90F□-T

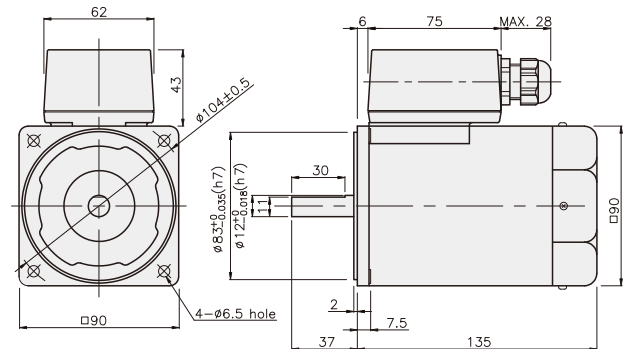

K9IS90F□-T5

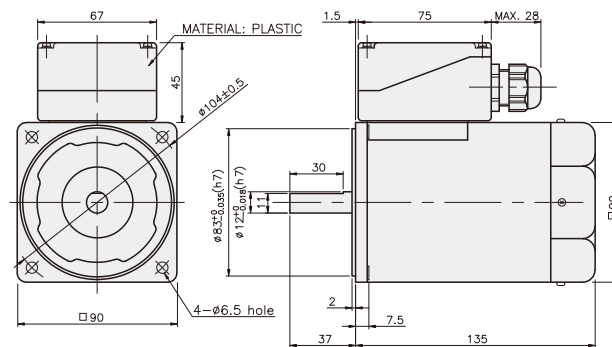

## GEARHEAD

### CONNECTION DIAGRAMS

K9IS90F□

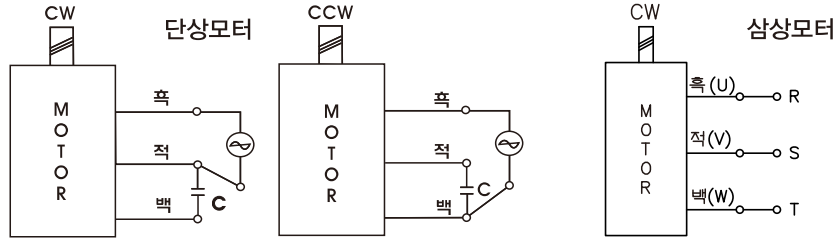

회전방향은 출력축에서 볼 경우

CCW는 U,V,W중 2선을 바꾸어 결선

K9IS90F□-T

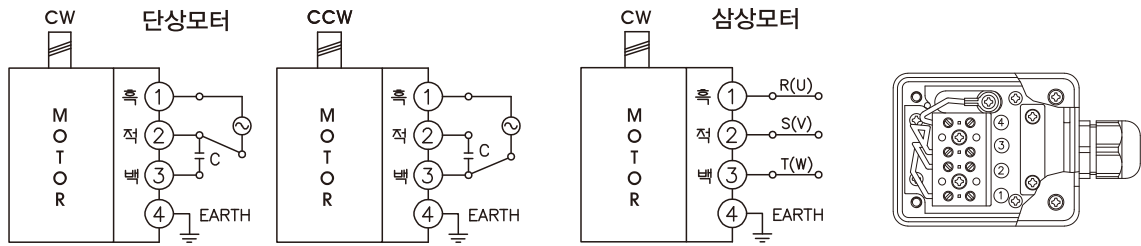

회전방향은 출력축에서 볼 경우

CCW는 U,V,W중 2선을 바꾸어 결선

K9IS90F□-T5

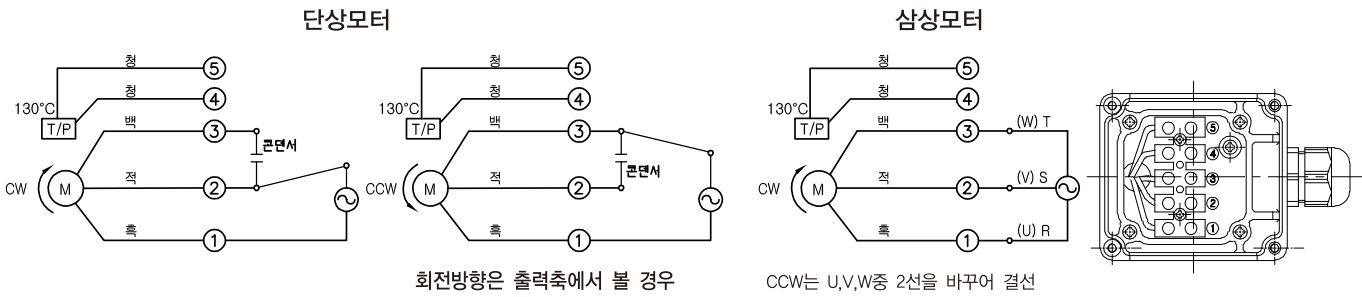

회전방향은 출력축에서 볼 경우

CCW는 U,V,W중 2선을 바꾸어 결선

## GEARHEAD

### DIMENSIONS

K9P□B



K9P□BF, BUF



K9P□BU



### DECIMAL GEARHEAD

K9P10BX

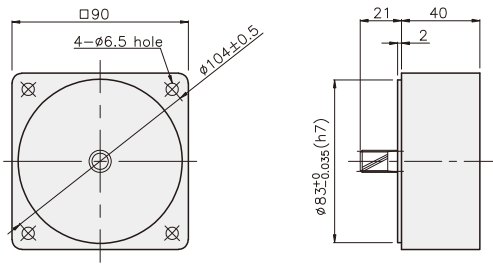

### KEY SPEC

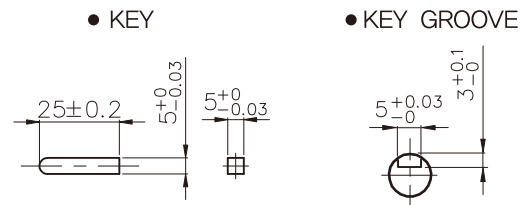

### GEARHEAD

K9P□B

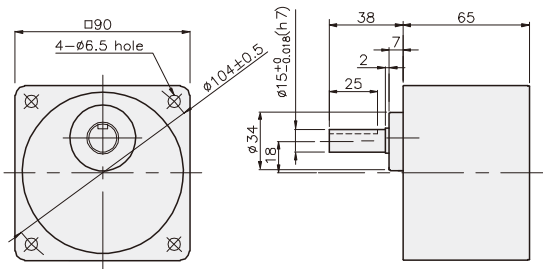

K9P□BF

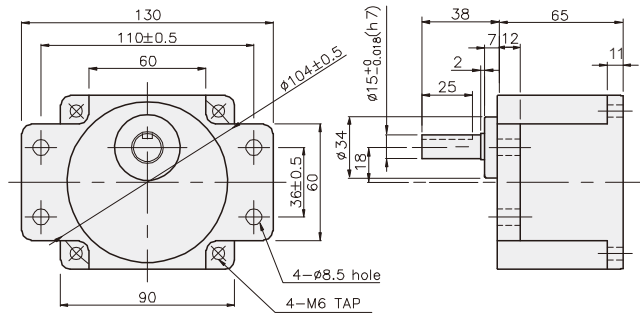

K9P□BU

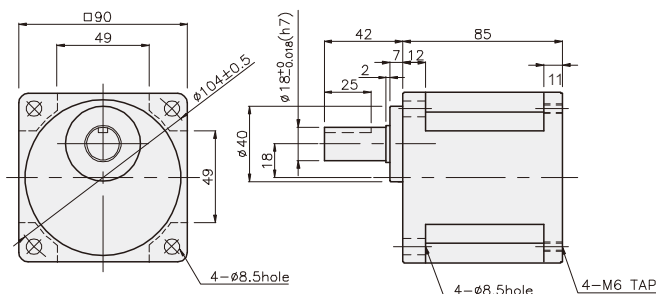

K9P□BUF

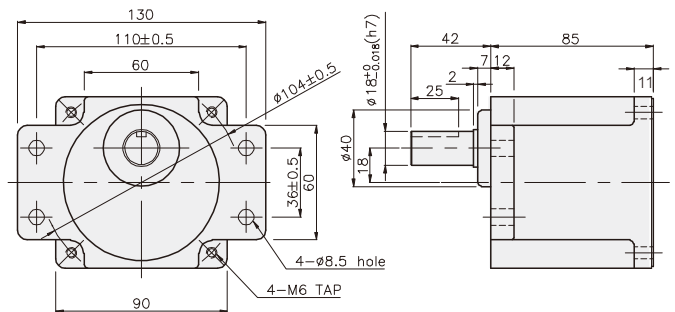

## GEARHEAD

### DIMENSIONS

K9IP90F□ + K9P□B



K9IP90F□ + K9P□BF, BUF



K9IP90F□ + K9P□BU



K9IP90F□ + K9P□B

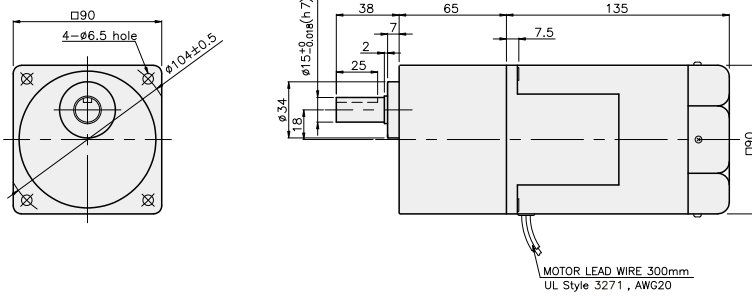

K9IP90F□ + K9P□BF

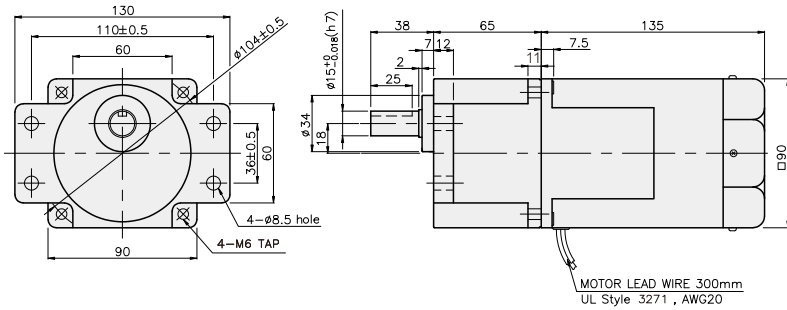

K9IP90F□ + K9P□BU

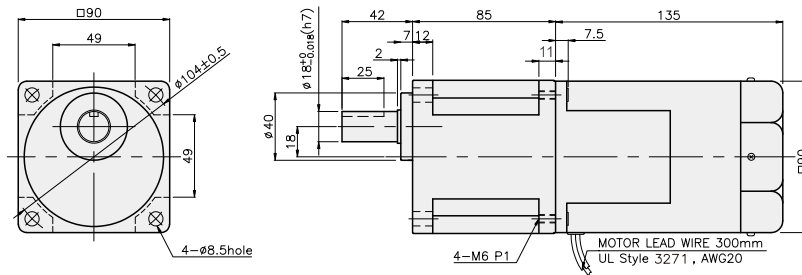

K9IP90F□ + K9P□BUF



#### 무게

PART	WEIGHT(kg)
MOTOR	3,00
DECIMAL GEARHEAD	0,62

#### 치수도표

품번	적용기종	취부 BOLT
01	K9P3~200B	M6 P1,0 X 95
02	K9P10BX	M6 P1,0 X 140

#### 무게

PART	WEIGHT(kg)
K9P3~10B	1,22
K9P12,5~20B	1,32
K9P25~60B	1,42
K9P75~200B	1,45

#### 치수도표

품번	적용기종	취부 BOLT
01	K9P3~200BF	M6 P1,0 X 20
02	K9P10BX	M6 P1,0 X 65

#### 무게

PART	WEIGHT(kg)
K9P3~10BF	1,22
K9P12,5~20BF	1,30
K9P25~60BF	1,42
K9P75~200BF	1,44

#### 치수도표

품번	적용기종	취부 BOLT
01	K9P3~200BU	M6 P1,0 X 20
02	K9P10BX	M6 P1,0 X 65

#### 무게

PART	WEIGHT(kg)
K9P3~10BU	1,44
K9P12,5~20BU	1,55
K9P25~60BU	1,69
K9P75~200BU	1,74

#### 치수도표

품번	적용기종	취부 BOLT
01	K9P3~200BUF	M6 P1,0 X 20
02	K9P10BX	M6 P1,0 X 65

#### 무게

PART	WEIGHT(kg)
K9P3~10BUF	1,50
K9P12,5~20BUF	1,62
K9P25~60BUF	1,76
K9P75~200BUF	1,82

K9IP90F□-T + K9P□B



K9IP90F□-T + K9P□BF, BUF



K9IP90F□-T + K9P□BU



**무게**

PART	WEIGHT(kg)
MOTOR	3.18
DECIMAL GEARHEAD	0.62

**치수도표**

품번	적용기종	취부 BOLT
01	K9P3~200B	M6 P1,0 X 95
02	K9P10BX	M6 P1,0 X 140

**무게**

PART	WEIGHT(kg)
K9P3~10B	1.22
K9P12,5~20B	1.32
K9P25~60B	1.42
K9P75~200B	1.45

**치수도표**

품번	적용기종	취부 BOLT
01	K9P3~200BF	M6 P1,0 X 20
02	K9P10BX	M6 P1,0 X 65

**무게**

PART	WEIGHT(kg)
K9P3~10BF	1.22
K9P12,5~20BF	1.30
K9P25~60BF	1.42
K9P75~200BF	1.44

**치수도표**

품번	적용기종	취부 BOLT
01	K9P3~200BU	M6 P1,0 X 20
02	K9P10BX	M6 P1,0 X 65

**무게**

PART	WEIGHT(kg)
K9P3~10BU	1.44
K9P12,5~20BU	1.55
K9P25~60BU	1.69
K9P75~200BU	1.74

**치수도표**

품번	적용기종	취부 BOLT
01	K9P3~200BUF	M6 P1,0 X 20
02	K9P10BX	M6 P1,0 X 65

**무게**

PART	WEIGHT(kg)
K9P3~10BUF	1.50
K9P12,5~20BUF	1.62
K9P25~60BUF	1.76
K9P75~200BUF	1.82

K9IP90F□-T + K9P□B



K9IP90F□-T + K9P□BF



K9IP90F□-T + K9P□BU

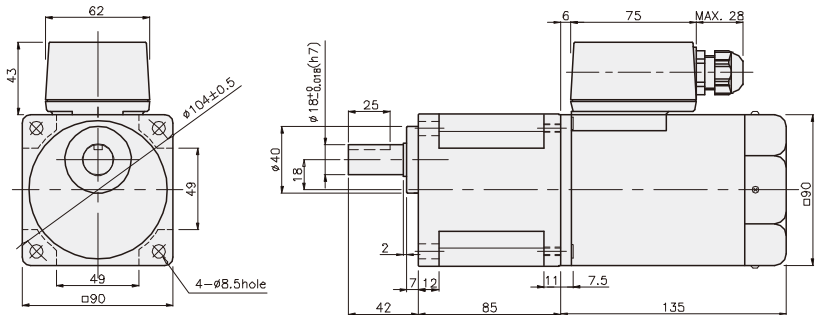

K9IP90F□-T + K9P□BUF

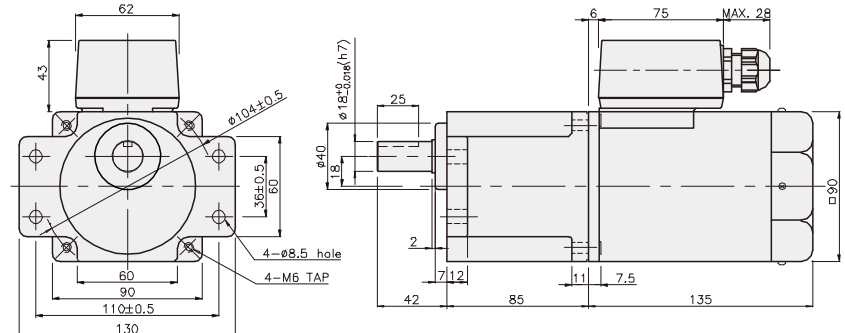

## GEARHEAD

### DIMENSIONS

K9IP90F□-T5 + K9P□B



K9IP90F□-T5 + K9P□BF, BUF



K9IP90F□-T5 + K9P□BU



K9IP90F□-T5 + K9P□B



K9IP90F□-T5 + K9P□BF

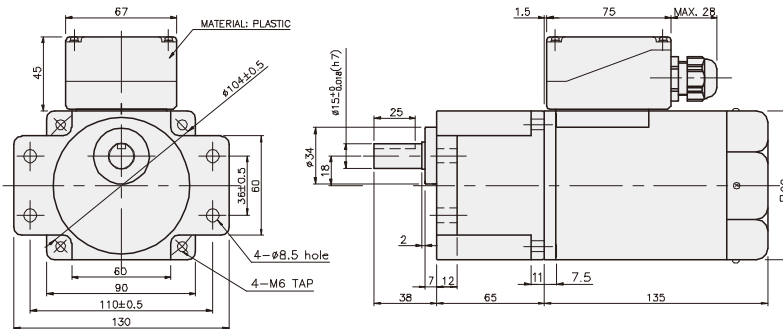

K9IP90F□-T5 + K9P□BU

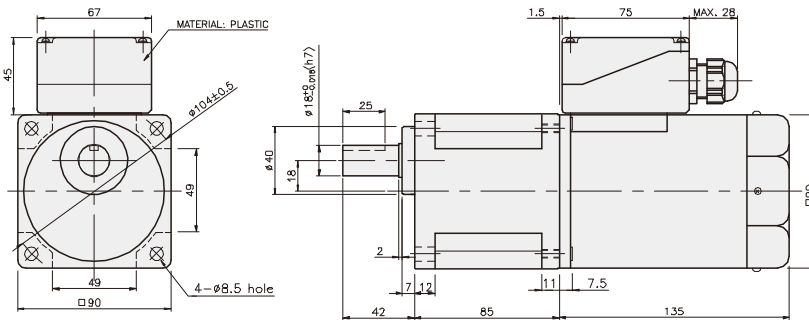

K9IP90F□-T5 + K9P□BUF

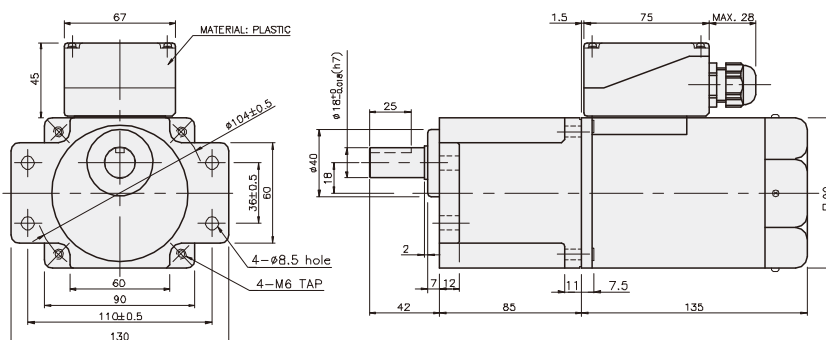

#### 무게

PART	WEIGHT(kg)
MOTOR	3,18
DECIMAL GEARHEAD	0,62

#### 치수도표

품번	적용기종	취부 BOLT
01	K9P3~200B	M6 P1,0 X 95
02	K9P10BX	M6 P1,0 X 140

#### 무게

PART	WEIGHT(kg)
K9P3~10B	1,22
K9P12,5~20B	1,32
K9P25~60B	1,42
K9P75~200B	1,45

#### 치수도표

품번	적용기종	취부 BOLT
01	K9P3~200BF	M6 P1,0 X 20
02	K9P10BX	M6 P1,0 X 65

#### 무게

PART	WEIGHT(kg)
K9P3~10BF	1,22
K9P12,5~20BF	1,30
K9P25~60BF	1,42
K9P75~200BF	1,44

#### 치수도표

품번	적용기종	취부 BOLT
01	K9P3~200BU	M6 P1,0 X 20
02	K9P10BX	M6 P1,0 X 65

#### 무게

PART	WEIGHT(kg)
K9P3~10BU	1,44
K9P12,5~20BU	1,55
K9P25~60BU	1,69
K9P75~200BU	1,74

#### 치수도표

품번	적용기종	취부 BOLT
01	K9P3~200BUF	M6 P1,0 X 20
02	K9P10BX	M6 P1,0 X 65

#### 무게

PART	WEIGHT(kg)
K9P3~10BUF	1,50
K9P12,5~20BUF	1,62
K9P25~60BUF	1,76
K9P75~200BUF	1,82