

DVB Master™ 2i/2o PCIe LP DVB-ASI PCIe Receiver/Transmitter Card with Two Input Ports Featuring Hardware Based Automatic Packet Size Detection, PID Filtering, and Packet Arrival Timestamping and Two Output Ports Featuring Enhanced Rate Control and Jitter Management.

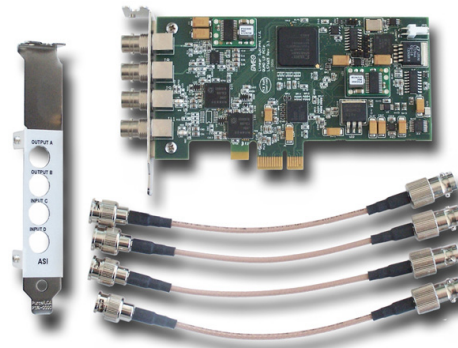

Features

- Two transmitter channels and two receiver channels on the same PCI Express card
- Comes with low profile and regular bracket
- Full DVB-ASI throughput of 213 Mbps per channel
- Multiple boards can be used for more inputs and outputs
- Cable equalization on receive channels
- Uses highly efficient Bus Master Link List DMA for data transform (saving CPU resources)
- Provides an interface for Layer-0 & Layer-1 of the DVB-ASI standard
- External clock input via NTSC or PAL black burst signal (available from on-board header)
- Drivers for Windows® 7 32 and 64 bit, Server 2003, Server 2008, Windows® 2000, Windows® XP, and Linux®
- Windows® XP/Server 2003/Server 2008/Linux® API
- DirectShow® filter
- Advanced Receiver Capabilities –
 - Synchronizes incoming packets to byte boundaries
 - Automatic 188- and 204-byte packet size detection
 - Interrupt on in/out of sync
 - Software selectable option to strip 16 bytes from 204 byte packets
 - Unlimited PID filtering (any number of PIDs may be selected)
- Advanced Transmitter Capabilities –
 - Enhanced transmit rate “Fine Tuning” control to <2.8ppm granularity
 - Software selectable option to add sixteen 0x00 bytes to 188 byte packets
 - External transmit clock input
- Mini-BNC to BNC adapter cables included

Applications

- DVB VoD (Video on Demand) Servers
- Cable TV
- Broadcast TV

Overview

Worldwide the television industry is currently in the process of changing from analog to digital technology. MPEG-2 has now been universally adopted as the main standard for video compression. Since MPEG-2 must be decoded at the same rate it was encoded, an information layer needs to be added to the MPEG in order to transmit it to end users. Standards have been created by industry to provide for the methodology of packetizing MPEG-2 streams and adding encoding information in tables via data packets to the video packets. The DVB standard has been approved by the European Community and other industry and government groups as the standard to accommodate the need for satellite and terrestrial originated digital television. This product complies with the DVB-ASI specifications as defined in ETSI TR 101 891 and provides for the ability of computers to capture, process, and transmit DVB-ASI compliant streams.

DVB-ASI streams are routinely used to send and receive transport streams between different brands of equipment. These transport streams can be single program transport streams or multiprogram transport streams. Interestingly, RF modulators determine the maximum size of transport streams. QAM modulators can handle 38 Mbps, 8VSB modulators can handle 19.3 Mbps, and DVB-S2 can handle over 60 Mbps. Of course IP backbones can routinely transfer 100 Mbps transport streams. It is also worthwhile to note that H.264 streams can be embedded into any MPEG-2 stream. Our DVB-ASI interface cards can handle them all.



Computer Modules, Inc.

11409 West Bernardo Court
San Diego, CA 92127

Tel: 858-613-1818 Fax: 858-613-1815

www.dveo.com

Specifications

| | |
|-----------------------------------|---|
| Dimensions | |
| Width: | 2.71 in. (6.89 cm) |
| Length: | 4.72 in. (11.99 cm) |
| Thickness: | 0.062 in. (0.157 cm) |
| Typical Weight | 2.8 oz. (79 g) |
| Input/Output Connectors | 75-ohm Mini BNC |
| External Clock Input | Blackburst NTSC/PAL (header) |
| Data Input/Output | DVB-ASI Coaxial, 2 kbps to 213 Mbps data rate |
| Typical Power | 590 mA @ 3.3 V 20 mA @ 12 V |
| Operating Temperature | 0 to 55°C |
| Operating Humidity | To 90%, Non-condensing |
| Status LED Indicators | Rx with Carrier Detect, Tx |
| Receive/Transmit FIFO Size | 4 kB per receive channel 8 kB per transmit channel |
| Bus Interface | Single Lane (x1) PCIe 1.1 |
| Driver Support | Windows® 7 – 32 and 64 bit, Windows XP, Windows Server 2003, Windows Server 2008, and Linux® |
| DVB Standards | CENELEC EN50083-9: 1998 – Cable distribution systems for television, sound and interactive services – Part 9: Interfaces for CATV/SMATV headends and similar professional equipment for DVB/MPEG-2 transport streams. |

Block Diagram

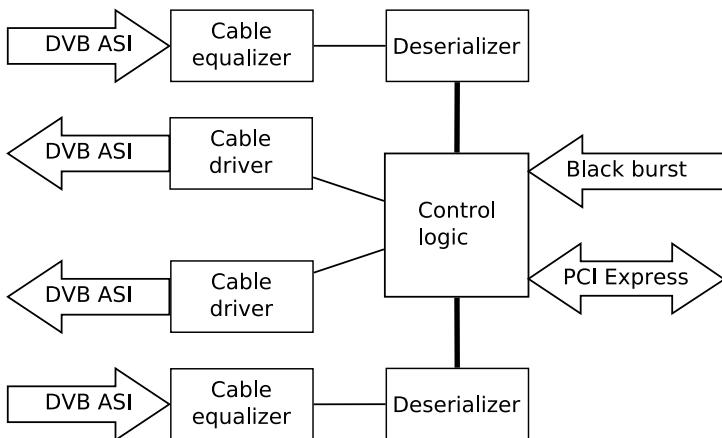

Ordering Information

DVB Master™ 2i/2o PCIe LP (Model 173)

© 2015 Computer Modules, Inc. DVEO and DVB Master are trademarks of Computer Modules, Inc. DVB is a registered trademark of the DVB Project. All other trademarks and registered trademarks are the properties of their respective owners. All rights reserved. Specifications are subject to change without notice.

Receiver Capabilities

Receive Packet Synchronization – The DVB Master 2i/2o PCIe LP receiver checks the incoming transport stream for packet sync, and synchronizes on it. Once synchronized, the packets are stored on packet boundaries in memory. This makes further processing of the transport stream much easier for the host processor.

Packet Arrival Timestamping – Under software control, each packet is timestamped with an arrival time generated by an internal timer/counter.

Null Packet Insertion – Under software control but performed by hardware, "null packets" are automatically inserted into the bit stream to replace filtered PIDs.

Automatic Packet Size Detection – The DVB Master 2i/2o PCIe LP automatically detects packet size and indicates the current size in a status register. If packet size changes suddenly, it will lose synchronization, then resynchronize on the new packet size and indicate the new packet size in the status register.

In/Out of Sync Interrupt – An interrupt is generated whenever synchronization is lost or recovered. Interrupts indicate that the status of the stream should be checked.

16 byte Strip – The 16 byte Stripping function removes the extra 16 Reed-Solomon encoded bytes from the 204 byte packets to create 188-byte packets.

PID Filtering – Select any number of PIDs from the total of over 8,000 possible PIDs to be filtered from the stream. The DVB Master 2i/2o PCIe LP receiver channels block all PIDs that are not selected.

Transmitter Capabilities

Transmitter Fine Tuning – In some applications, such as reading files from a disk, it may be desirable to use stuffing to control the transmission rate of the stream to match the rate required by the Program Clock Reference (PCR) of a Transport Stream. Because of this, we have developed the Fine Tuning (FT) feature. Fine Tuning is accomplished by first setting the standard IP and IB to select a rate as close to the desired rate as possible. Then the FT parameter can be set to bring the rate within 2.5 ppm of the target. This method of rate control works with small transmit buffers and gives minimum latency.

Software Controlled Transmit Clock Selection – The transmit clock options include the Black Burst clock, External Clocks and Internal Clock. The black burst input accepts a black burst signal for either NTSC or PAL video and is available as an on-board header.

Null Packet Insertion – Under software control but performed by hardware, "null packets" are automatically inserted into the bit stream.

PCR Pacing – Firmware support is available for releasing PCR packets at the correct PCR time. This method ensures that the transmit rate and PCR timing are the same as the original input stream.

Reed-Solomon Conversion – The software can be set to have hardware add 16 bytes filled with zeros to 188-byte packets to create a 204-byte packet stream.

DVEO
Broadcast Division

Computer Modules, Inc.

11409 West Bernardo Court

San Diego, CA 92127

Tel: 858-613-1818 Fax: 858-613-1815

www.dveo.com