

PALMS

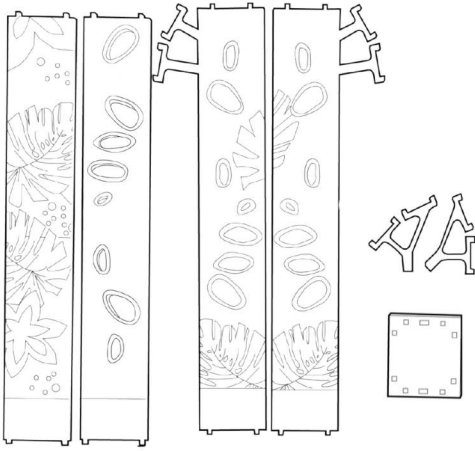

START HERE

MATERIALS + TOOLS



LARGE TOWER

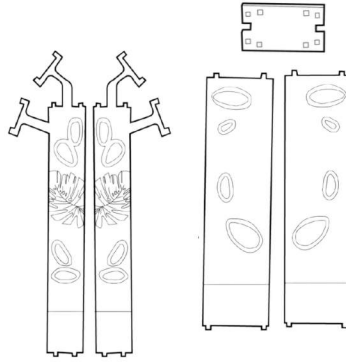

MEDIUM TOWER

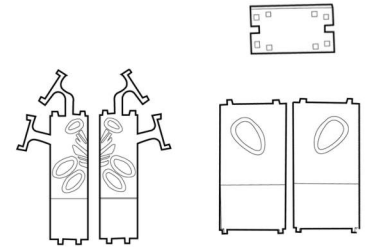

SMALL TOWER

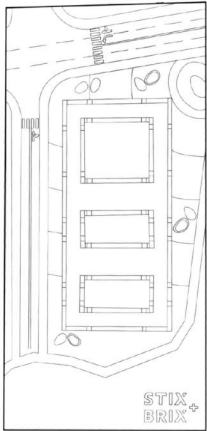

BASE

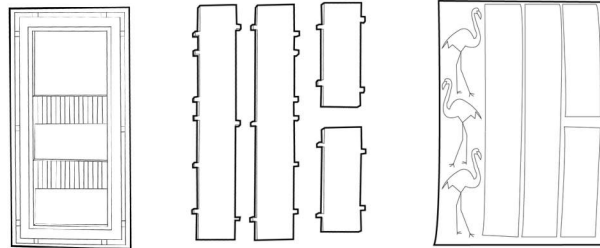

LOWER FLOORS + STICKERS

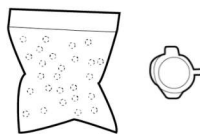

PEOPLE + CARS +
BOATS + SAND

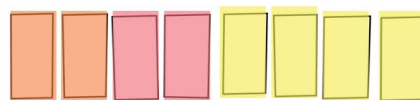

ACRYLIC PIECES

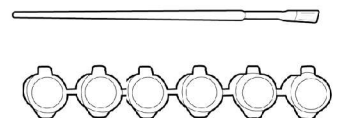

PAINT BRUSH + PAINT

1

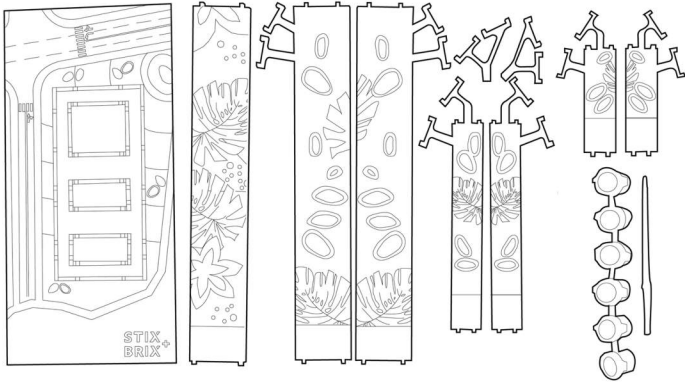

PAINT THE WOOD PIECES YOU WOULD LIKE.
 LET PIECES DRY COMPLETELY.
 +MURAL TIP: 1 = ORANGE, 2 = PINK, 3= YELLOW,
 4= GREEN.

2

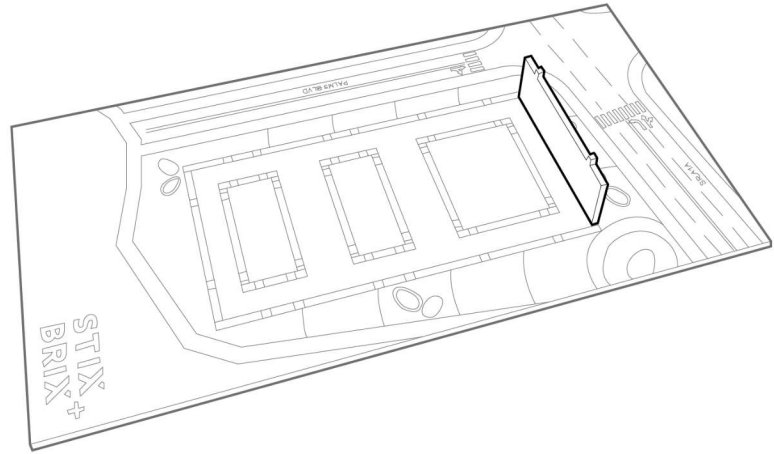

START WITH THE BASE AND LOCK-IN A SHORT WALL FOR THE PODIUM.

3

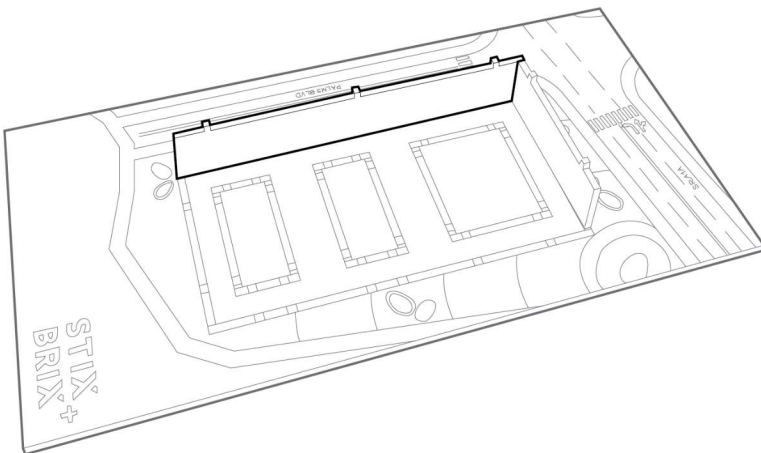

LOCK-IN A LONG PODIUM WALL INTO THE BASE.

4

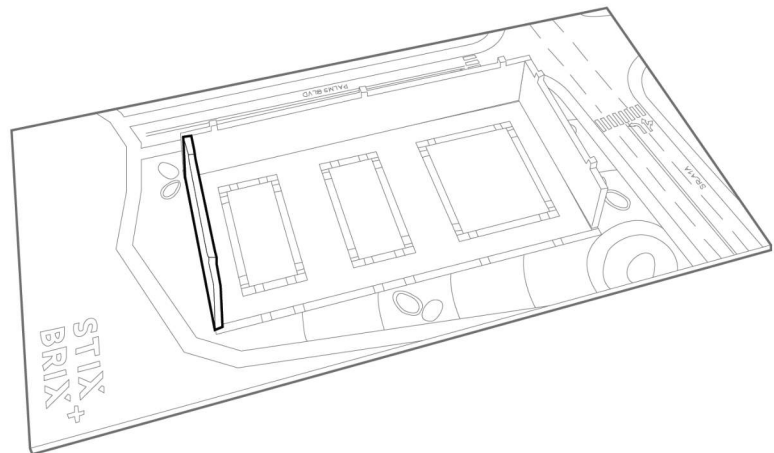

LOCK-IN A SHORT WALL INTO THE BASE.

5

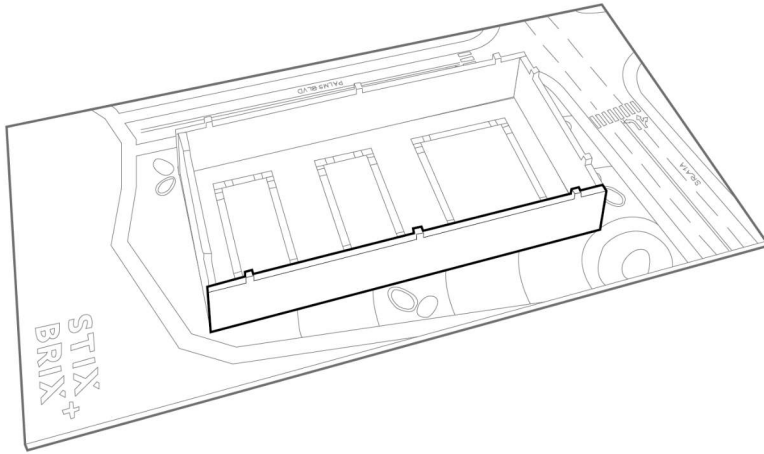

LOCK-IN THE LAST PODIUM WALL INTO THE BASE.

6

+ Be sure that all the connections are made before moving on to next step. Medium pressure / force can be used to engage all the tabs.
 +You can add lower floor stickers

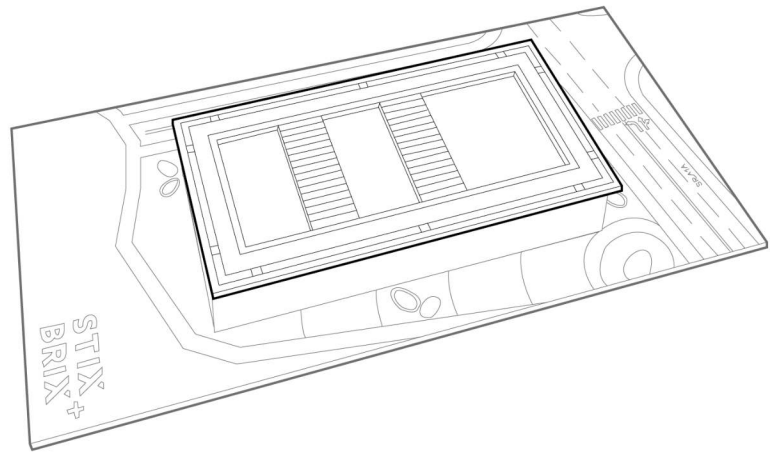

LOCK IN THE ROOF TO THE TOP OF THE WALLS.

7

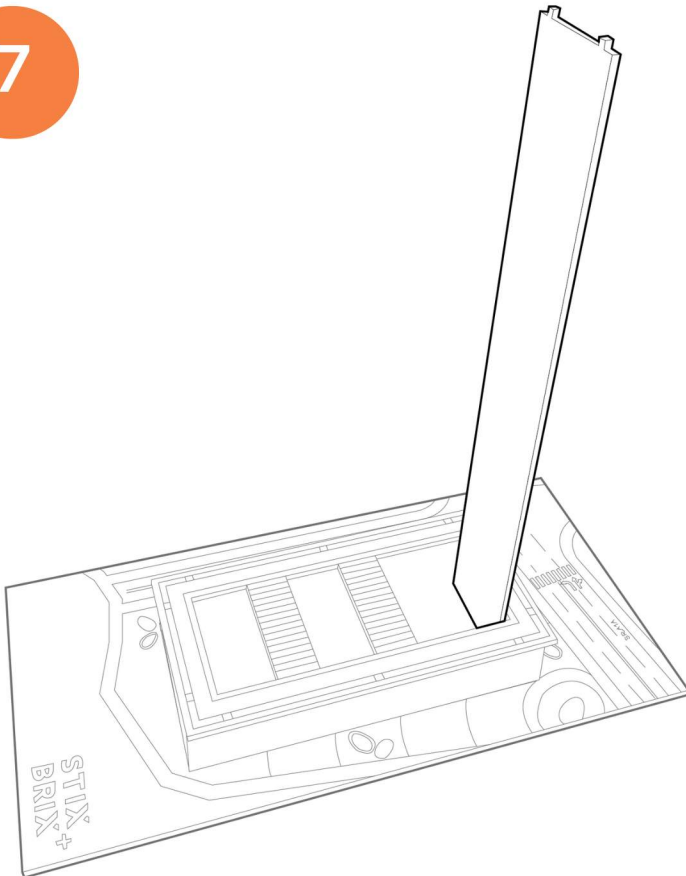

LOCK-IN THE MURAL WALL INTO THE BASE.

8

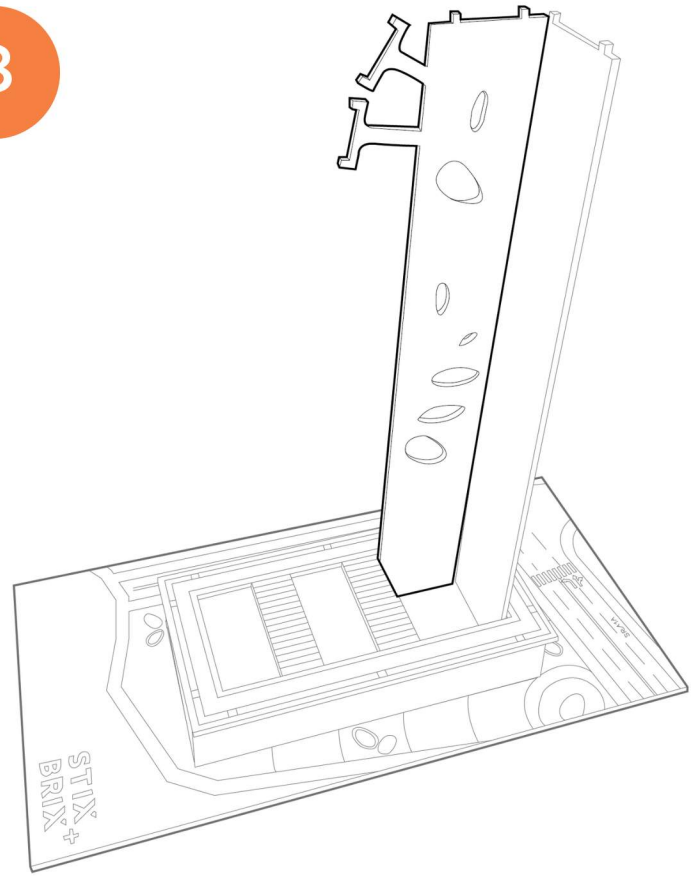

LOCK-IN THE LARGE TOWER WALL INTO THE BASE.

9

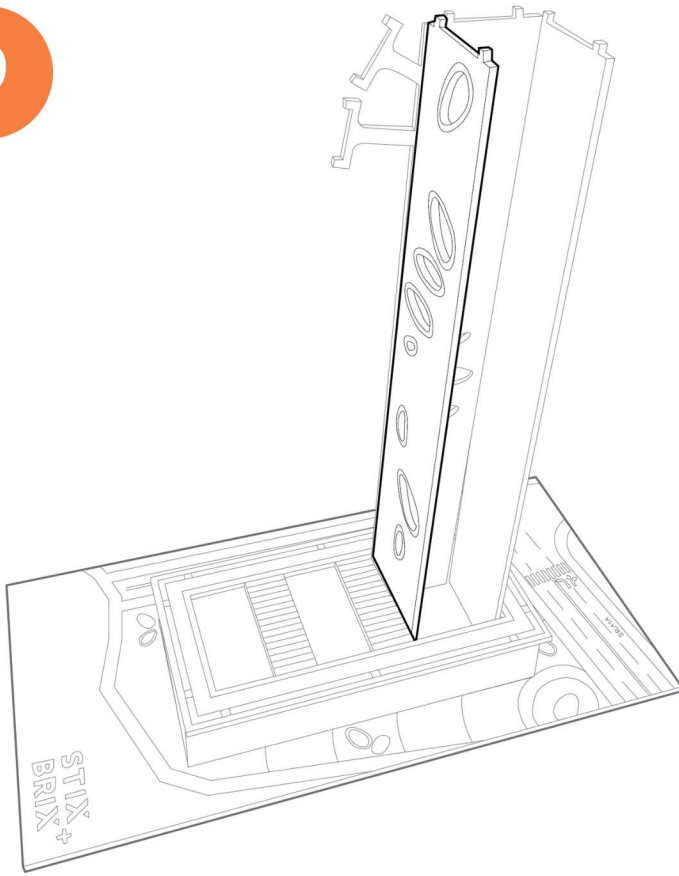

LOCK-IN THE LARGE TOWER WALL INTO THE BASE.

10

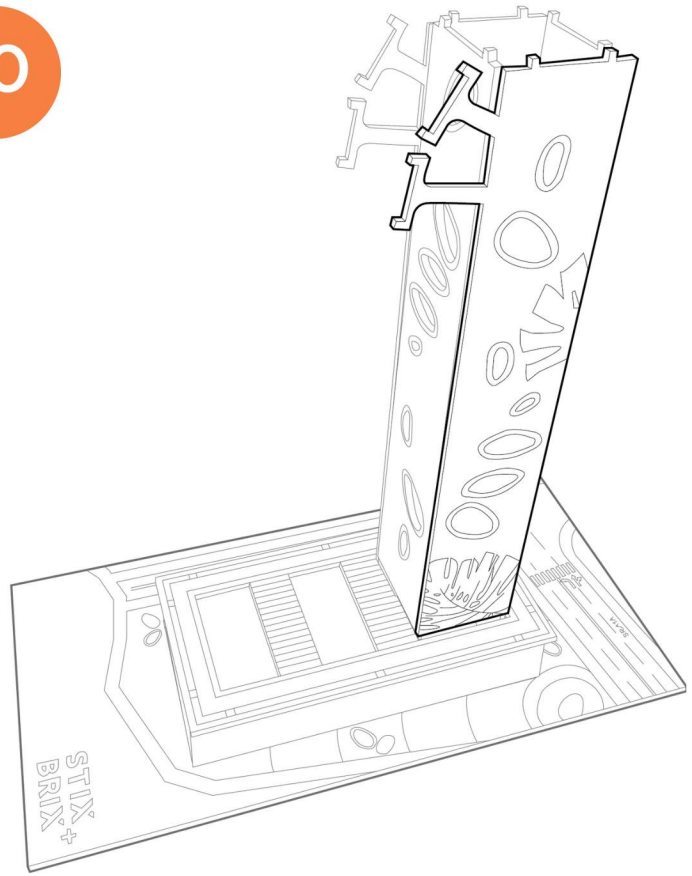

LOCK-IN THE LARGE TOWER WALL INTO THE BASE.

11

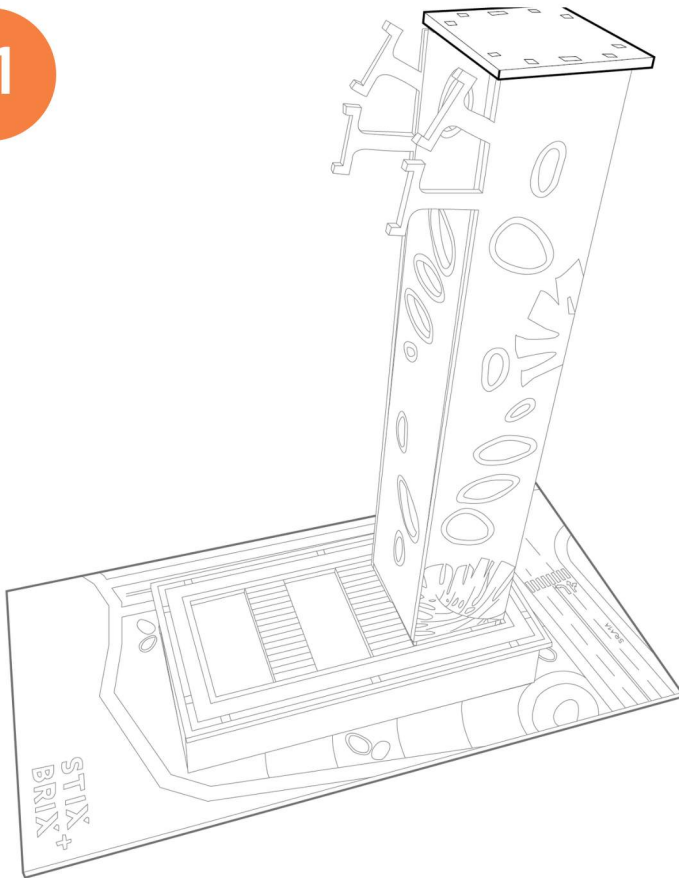

LOCK-IN THE LARGE TOWER ROOF ONTO THE TOP OF THE LARGE TOWER WALLS.

12

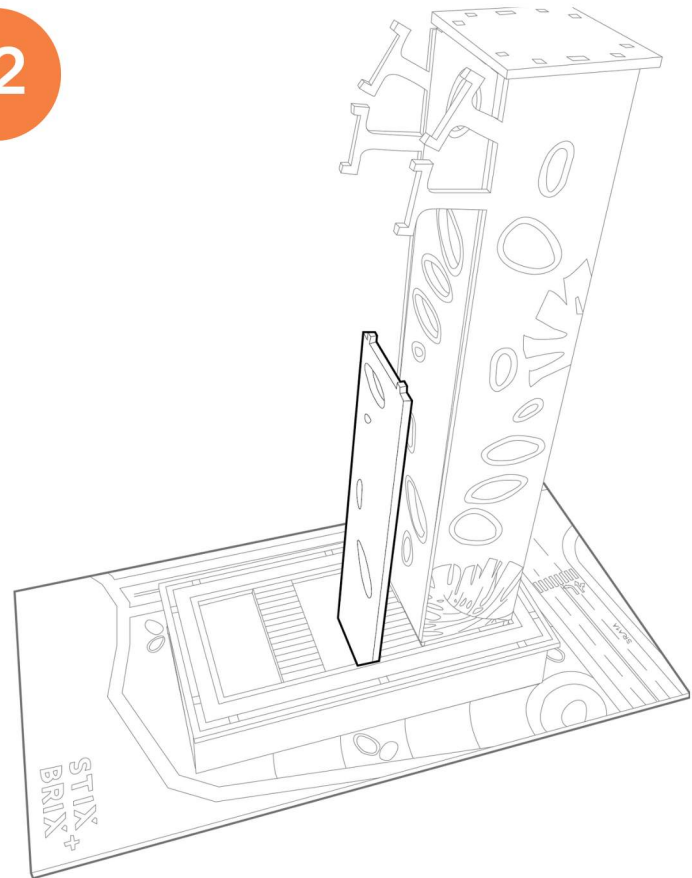

LOCK-IN THE MEDIUM TOWER WALL INTO THE BASE.

13

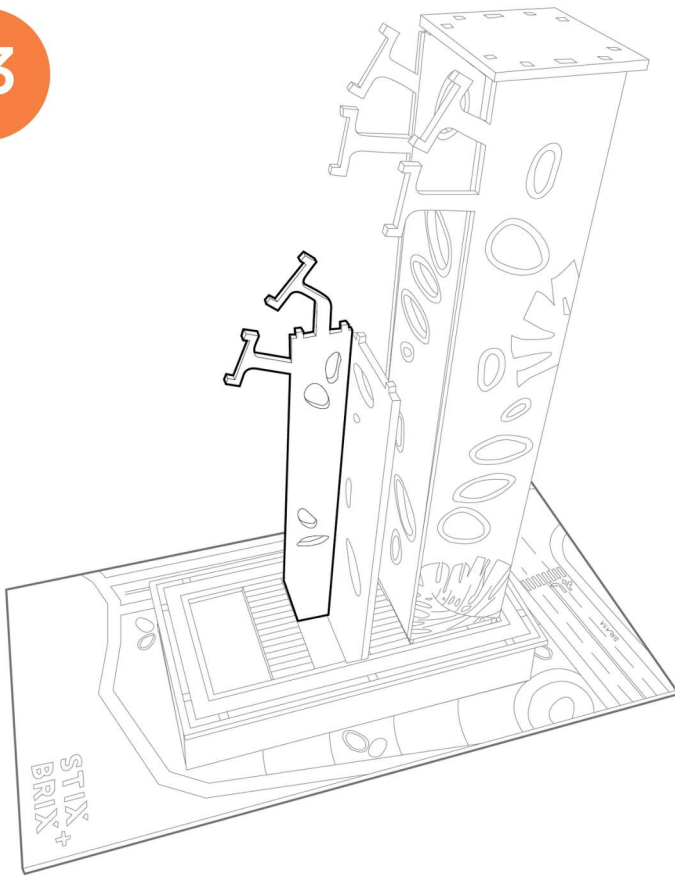

LOCK-IN THE MEDIUM TOWER WALL INTO THE BASE.

14

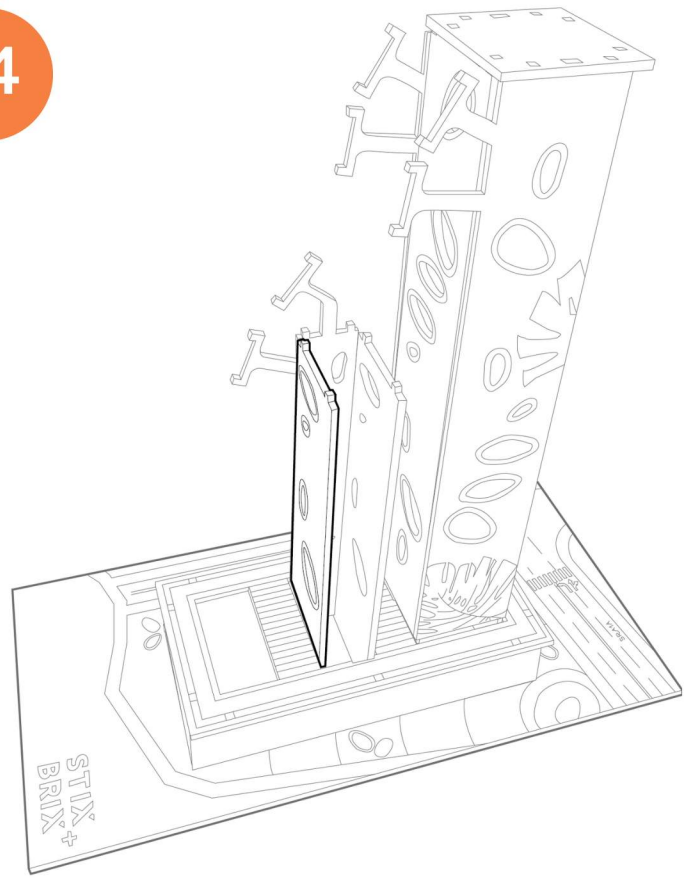

LOCK-IN THE MEDIUM TOWER WALL INTO THE BASE.

15

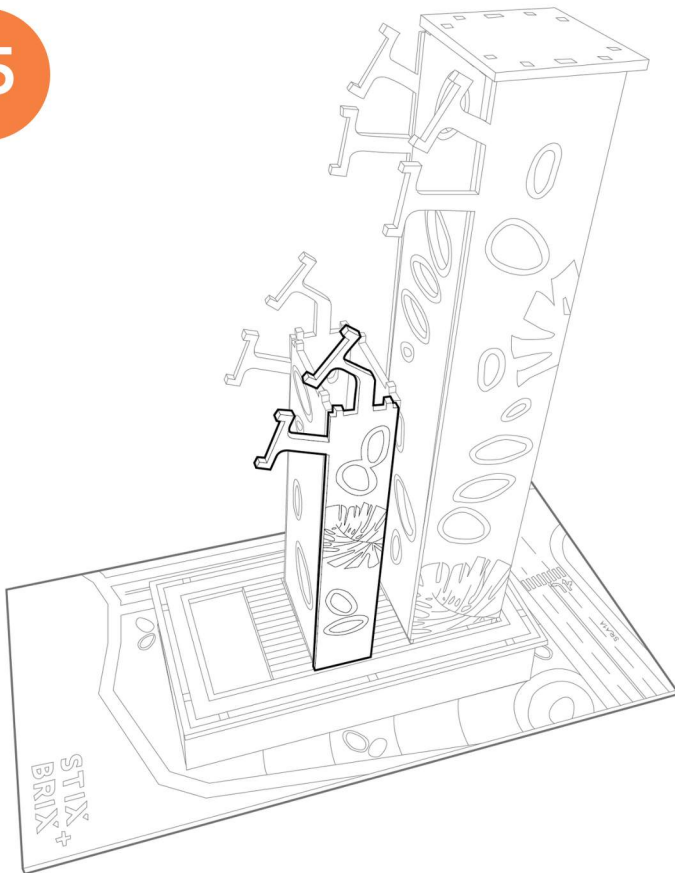

LOCK-IN THE LAST MEDIUM TOWER WALL INTO THE BASE.

16

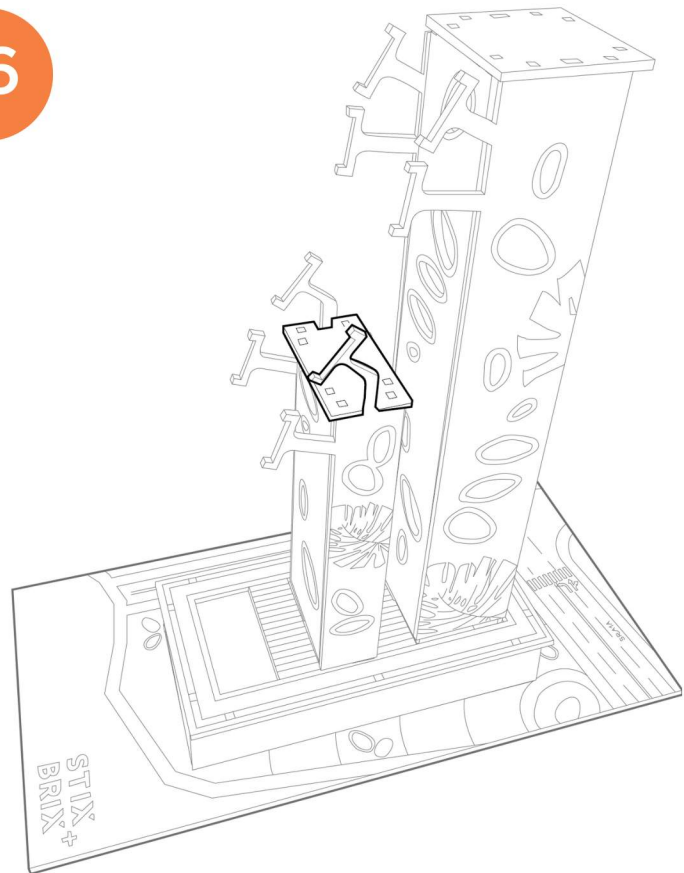

LOCK-IN THE MEDIUM TOWER ROOF ONTO THE TOP OF THE MEDIUM TOWER WALLS.

17

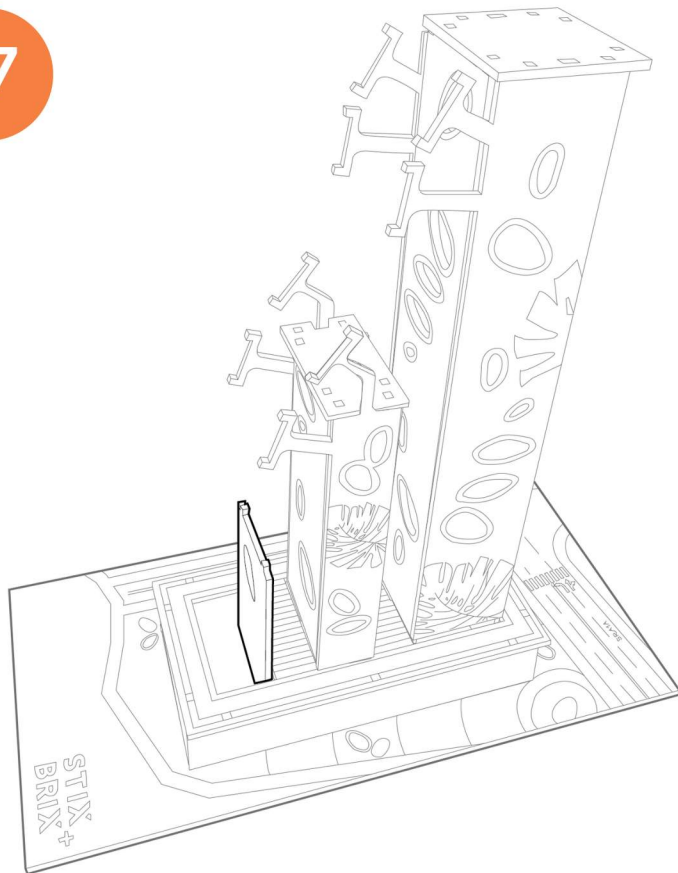

LOCK-IN THE SMALL TOWER WALL INTO THE BASE.

18

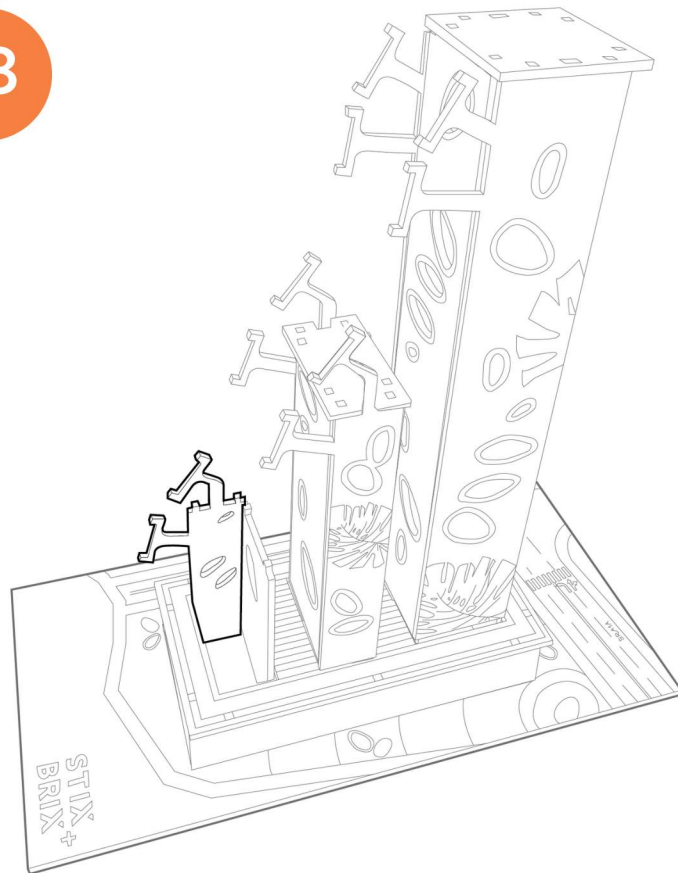

LOCK-IN THE SMALL TOWER WALL INTO THE BASE.

19

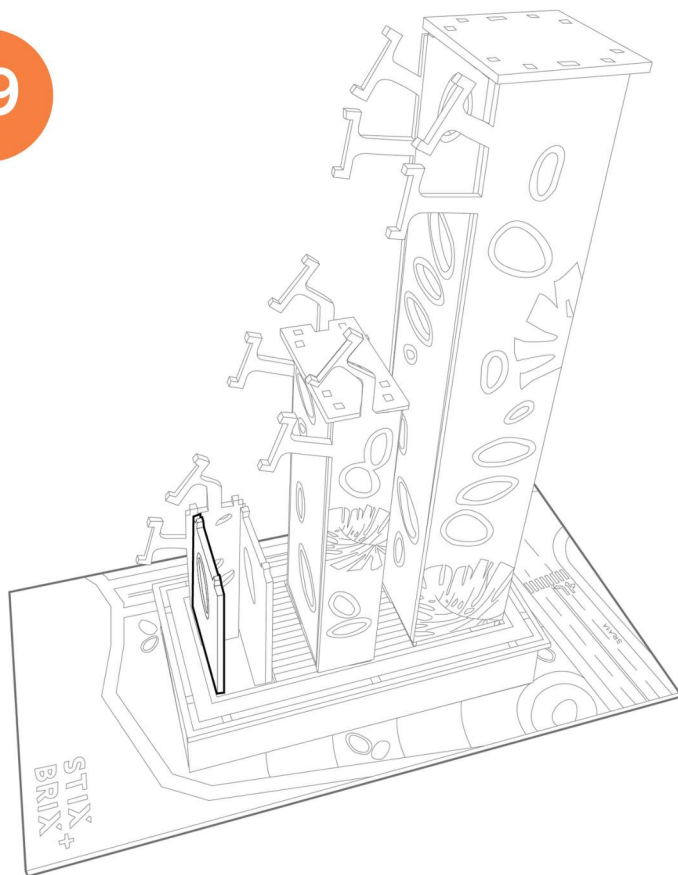

LOCK-IN THE SMALL TOWER WALL INTO THE BASE.

20

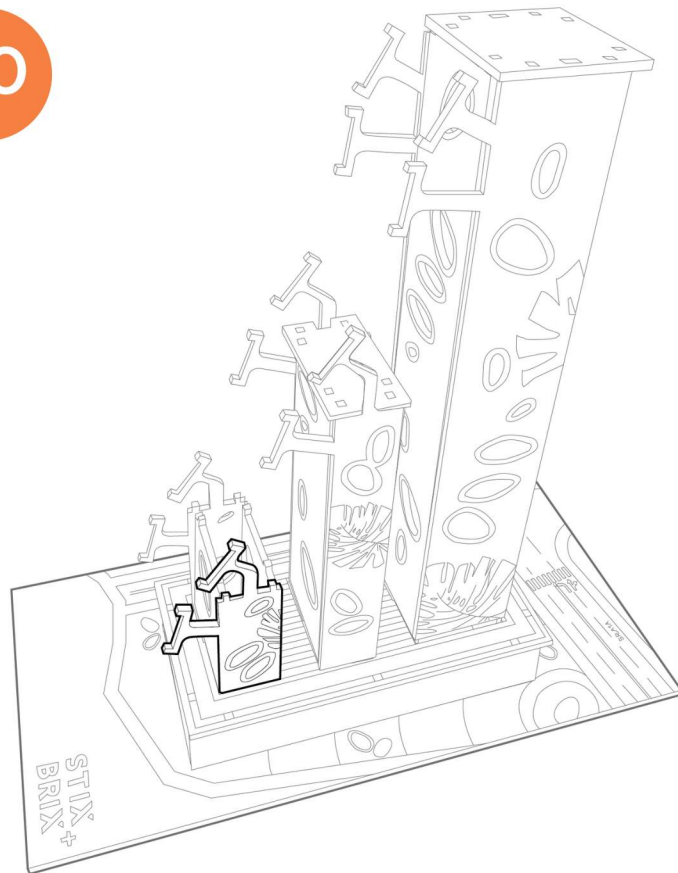

LOCK-IN THE SMALL TOWER WALL INTO THE BASE.

21

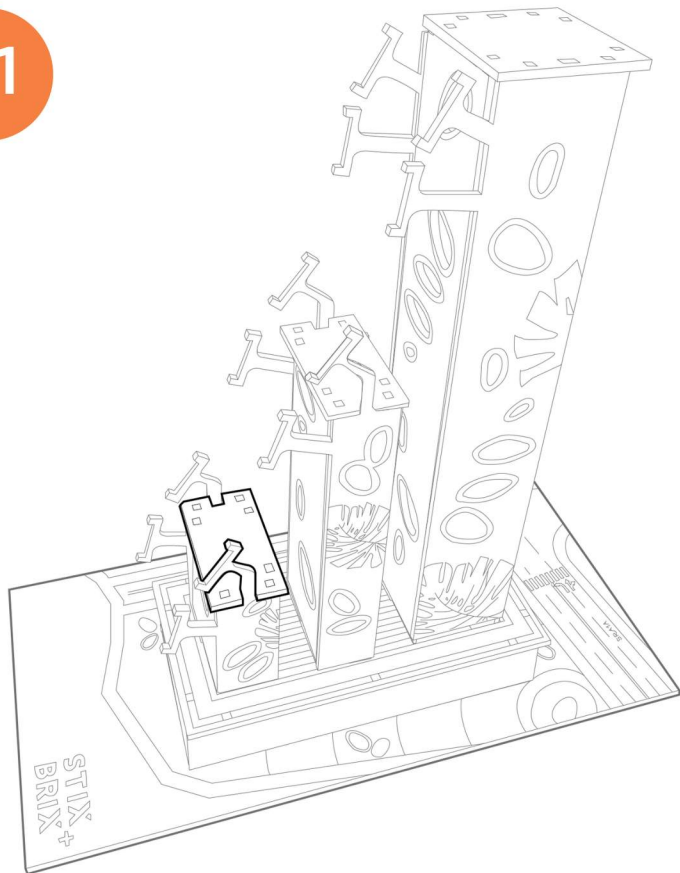

LOCK-IN THE SMALL TOWER ROOF ONTO THE TOP OF THE SMALL TOWER WALLS.

22

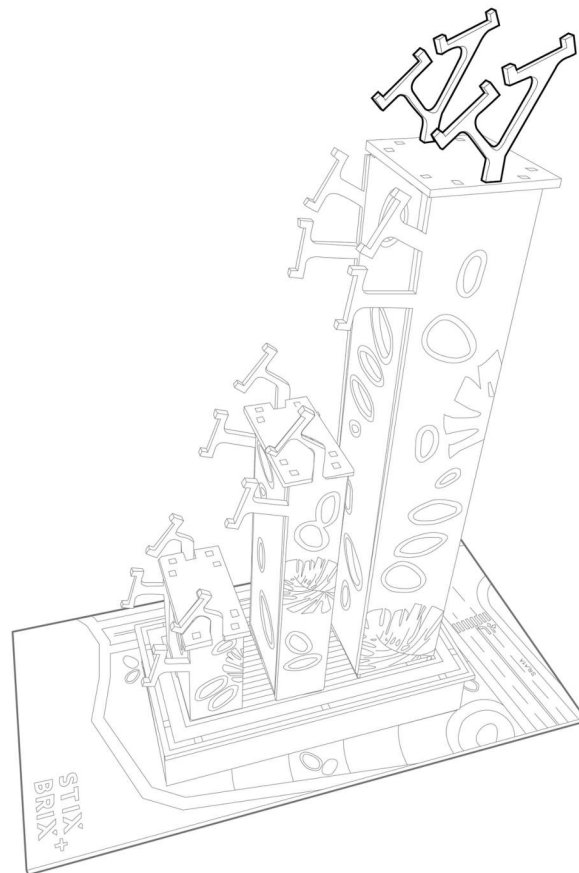

LOCK-IN THE 2 BRACKETS ONTO THE ROOF OF THE LARGE TOWER.

23

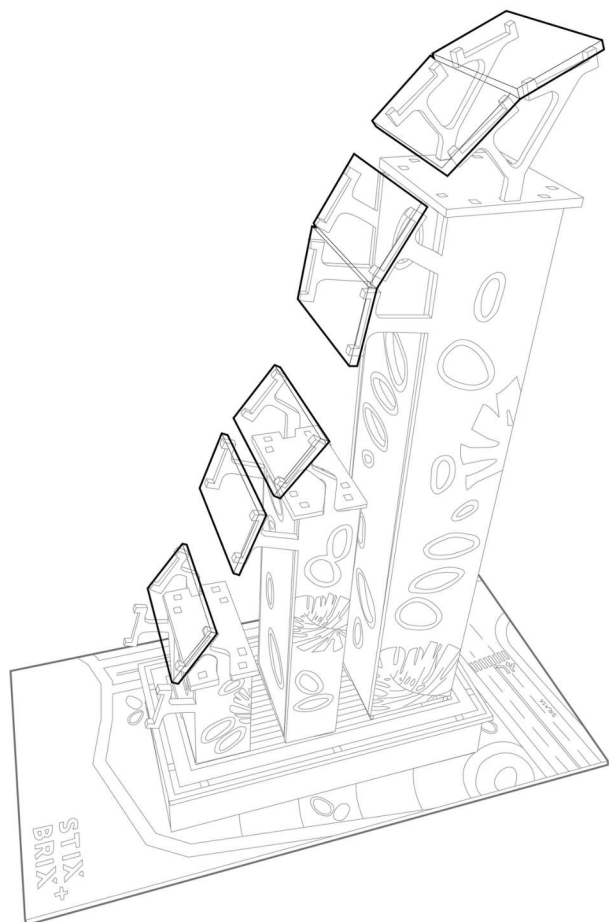

LOCK-IN THE COLOR SUN SHADES ONTO THE BRACKETS.

24

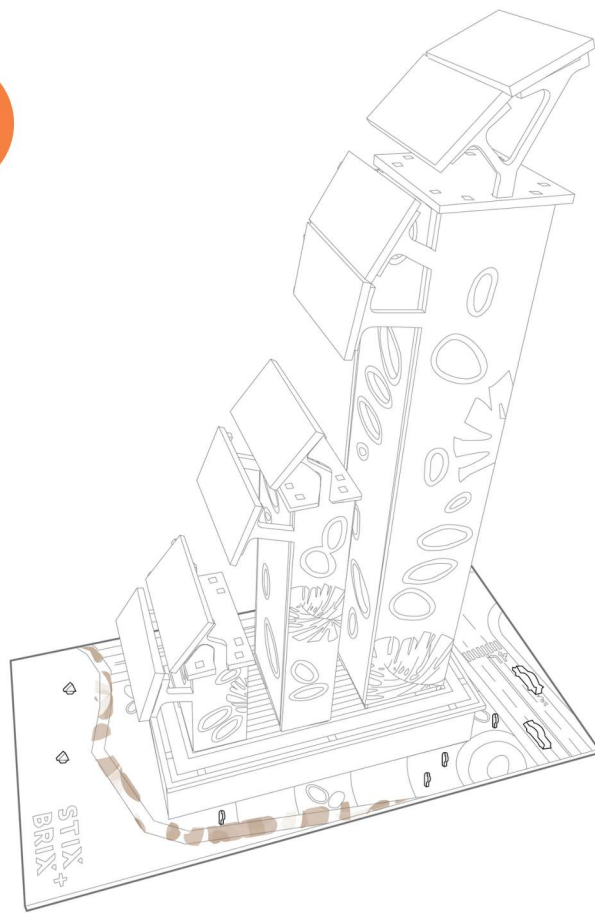

ADD STICKERS TO YOUR MODEL. FINISH THE BASE WITH SAND, CARS, BOATS AND PEOPLE. + TIP - GLUE THE BASE ITEMS IN PLACE.

PALMS

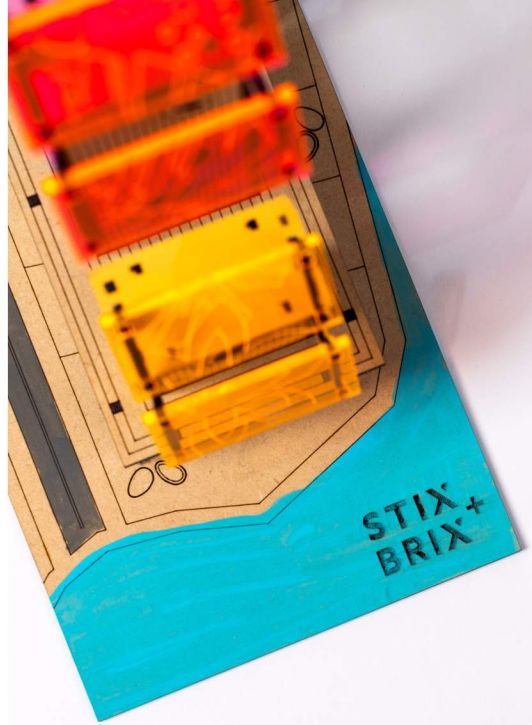

STIX-BRIX.COM

