

# PARTS LIST

## OUTLAW PB - DRY VACUUM

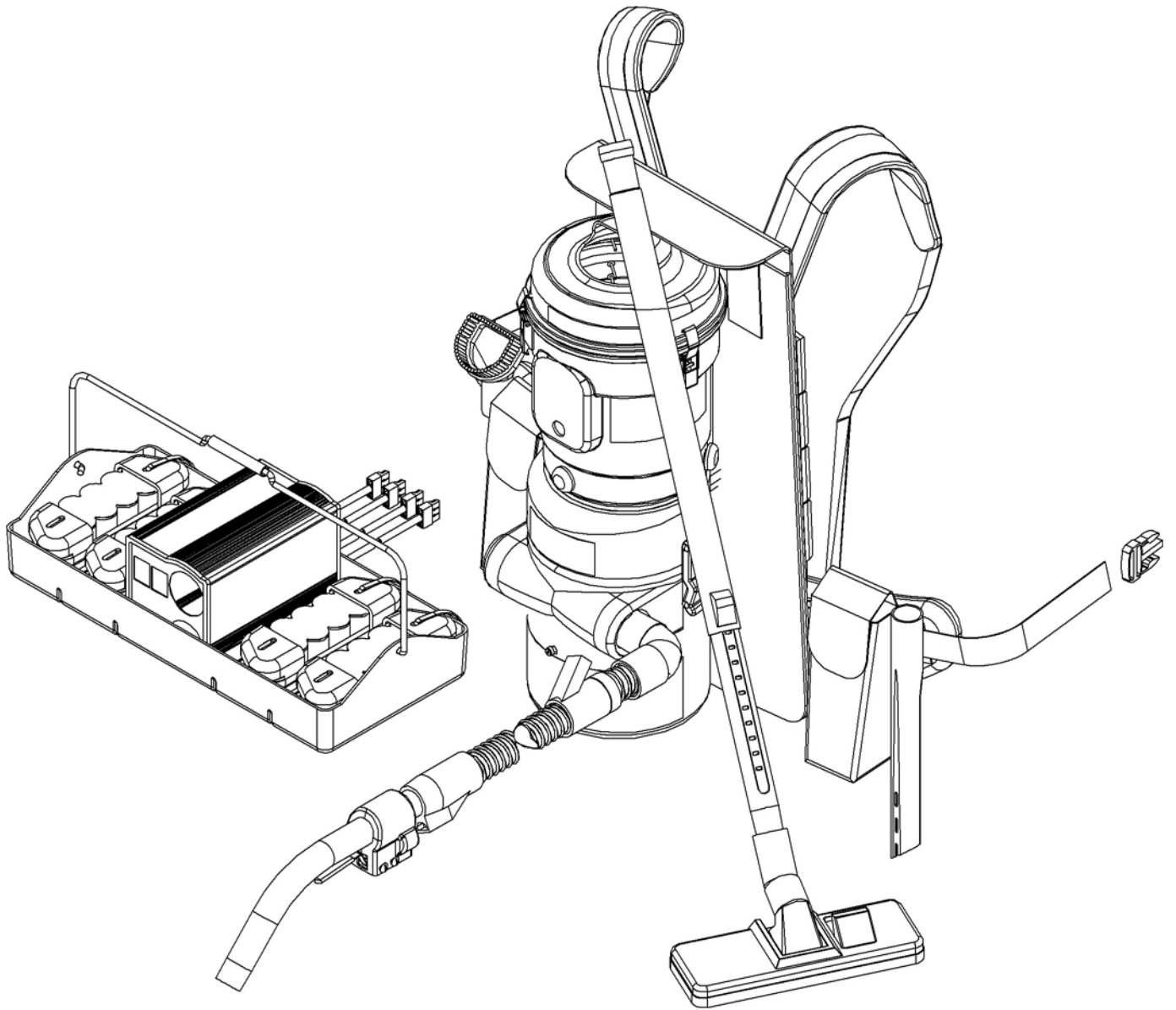

**SAVE THESE INSTRUCTIONS**



## **UPPER HOUSING ASSEMBLY**

<b>ITEM</b>	<b>PART NO.</b>	<b>DESCRIPTION</b>	<b>QTY</b>
	6990839	CAP ASSEMBLY - INCLUDES:	1
101	6990831	REPLACEMENT CAP	1
101A	6990391	WARNING LABEL KIT	1
101B	6793181	LATCH	3
101C	9120319	5/32 X 3/8 DIAMETER HEAD POP RIVET - STEEL - PACK OF 5	3
101D	6990261	HEPA FILTER GASKET	1
101E	6990251	FILTER CAP GASKET	1
102	6990381	EXHAUST FILTER – FOAM	1
103	6990241	FILTER SUPPORT	1
104	6991319	TOP & MOTOR HOUSING ASSEMBLY - INCLUDES:	1
104	6991311	TOP & MOTOR HOUSING	1
104A	9120319	5/32 X 3/8 DIAMETER HEAD POP RIVET - STEEL - PACK OF 5	6
104B	6793181	LATCH	3
104C	6990391	WARNING LABEL KIT	1
104E	6990291	SNAP RIVET	2
104F	6990391	WARNING LABEL KIT	1
104G	6990281	CIRCUIT BOARD SUPPORT	2
104H	6990431	WIRING DIAGRAM LABEL	1
104J	6491171	SOFT DRAW LATCH WITH KEEPER (NOT SHOWN)	2
104K	6991101	OUTLAW PB LABEL (NOT SHOWN)	1
105	6990441	PIGTAIL CORD - HOSE TO BOARD WITH STRAIN RELIEF	1
106	9120205	#8 X 1/2 PAN HEAD PHILLIPS SHEET METAL SCREW - PACK OF 3	1
107	6793271	FINISHING CAP WASHER	3
108	9121130	1/4-20 X 1 1/2 TRUSS HEAD PHILLIPS MACHINE SCREW - PACK OF 5	3
109	6793261	PLASTIC SCREW CAP	3
110	6990591	CABLE - BATTERY TO BOARD WITH STRAIN RELIEF	1
111	6990151	CIRCUIT BOARD	1
112	6793111	HEPA FILTER – OPTIONAL	1
113	9122900	3/4 INT STAR LOCK WASHER – PACK OF 5	1

# UPPER HOUSING ASSEMBLY

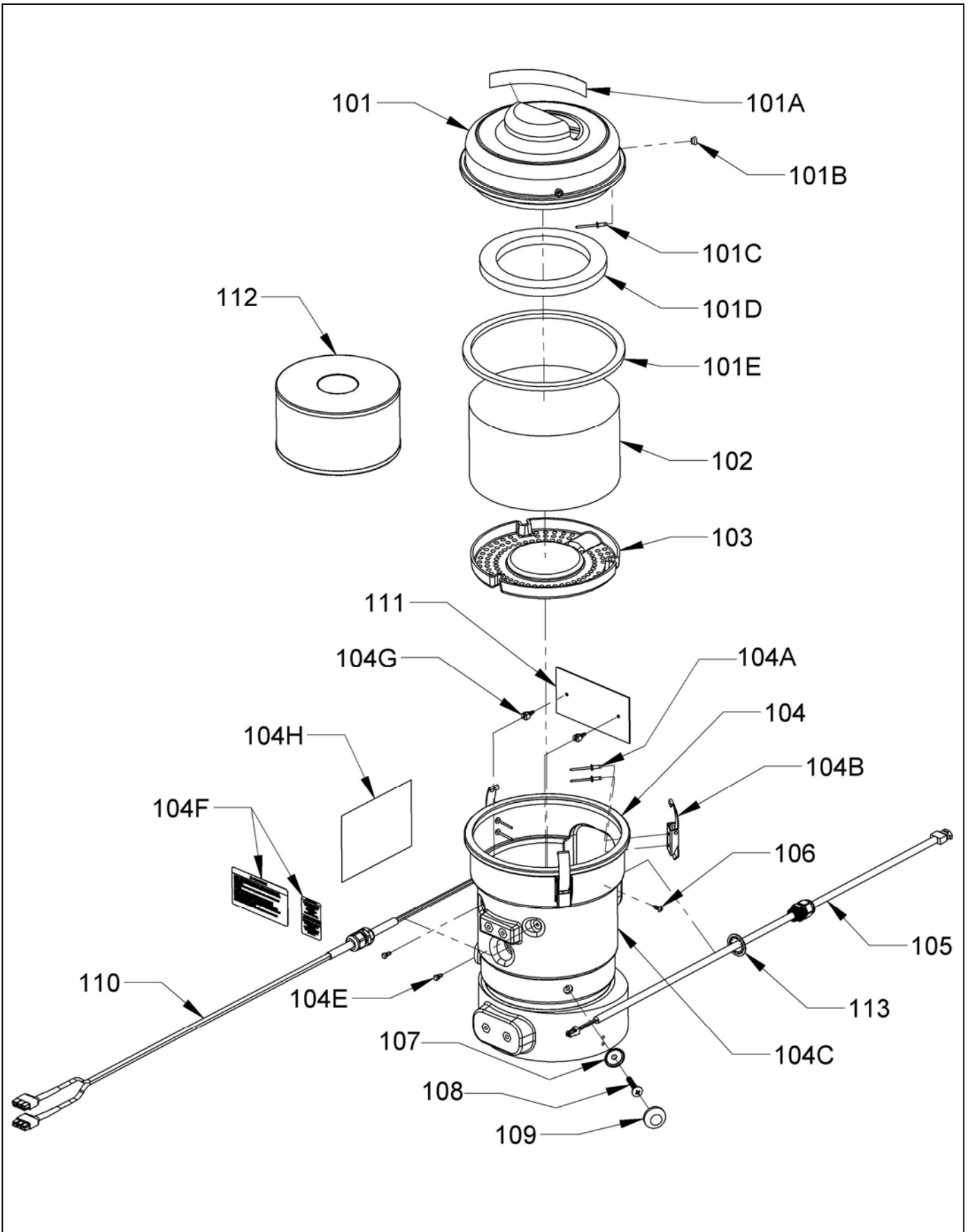

## **LOWER HOUSING ASSEMBLY**

<b>ITEM</b>	<b>PART NO.</b>	<b>DESCRIPTION</b>	<b>QTY</b>
201	3193111	VAC MOTOR CAP	1
202	9120625	#10-24 X 3/4 HEX WASHER HEAD SLOT THD CUTTING SCR - PACK OF 2	4
203	6990121	VACUUM MOTOR MOUNTING PLATE	1
204	-----	INSULATED FEMALE TERMINAL	2
205	6990171	VACUUM MOTOR	1
	2397571	CARBON BRUSH	2
206	6990131	MOTOR GASKET	1
207	6991319	TOP & MOTOR HOUSING ASSEMBLY - INCLUDES:	1
	6991311	TOP & MOTOR HOUSING	1
207A	6991101	NAMING LABEL	1
207B	9120319	5/32 X 3/8 DIAMETER HEAD POP RIVET - STEEL - PACK OF 5	4
207C	6491171	SOFT DRAW LATCH WITH KEEPER - KEEPER SHOWN	2
207D	6793181	CLAMP & BUTTON (NOT SHOWN)	3
207E	6990281	CIRCUIT BOARD SUPPORT (NOT SHOWN)	2
207F	6990291	SNAP RIVET (NOT SHOWN)	2
207G	6990391	WARNING LABEL KIT (NOT SHOWN)	1
207H	6990431	WIRING DIAGRAM LABEL (NOT SHOWN)	1
208	6793081	WELL NUT	3
209	6990111	FILTER	1
210	6990869	CANISTER ASSEMBLY - INCLUDES:	1
	6990861	CANISTER	1
210A	9120319	5/32 X 3/8 DIAMETER HEAD POP RIVET - STEEL - PACK OF 5	4
210B	6491171	SOFT DRAW LATCH WITH KEEPER - LATCH SHOWN	2
211	9121289	1/4 X 3/16 (10-24) SOCKET HEAD SHOULDER BOLT - PACK OF 1	1
212	9120890	1/4-20 THIN HEX NUT WITH NY-LOK INSERT - PACK OF 5	1
213	9120930	9/32 I.D. X 5/8 O.D. FLAT WASHER (1/4) - PACK OF 10	1
214	6990571	TAPERED PLUG	1
215	6990641	LANYARD	1
216	9121130	1/4-20 X 1 1/2 TRUSS HEAD PHILLIPS MACHINE SCREW - PACK OF 5	1
217	2694921	NSS LOGO LABEL	1
218	6991119	FILTER CUP AND GASKET KIT – INCLUDES	1
	6991071	CUP – FILTER	1
209A	6991091	GASKET, CANISTER TO FILTER	1
219	6991271	EMI SUPPRESSOR	1

# LOWER HOUSING ASSEMBLY

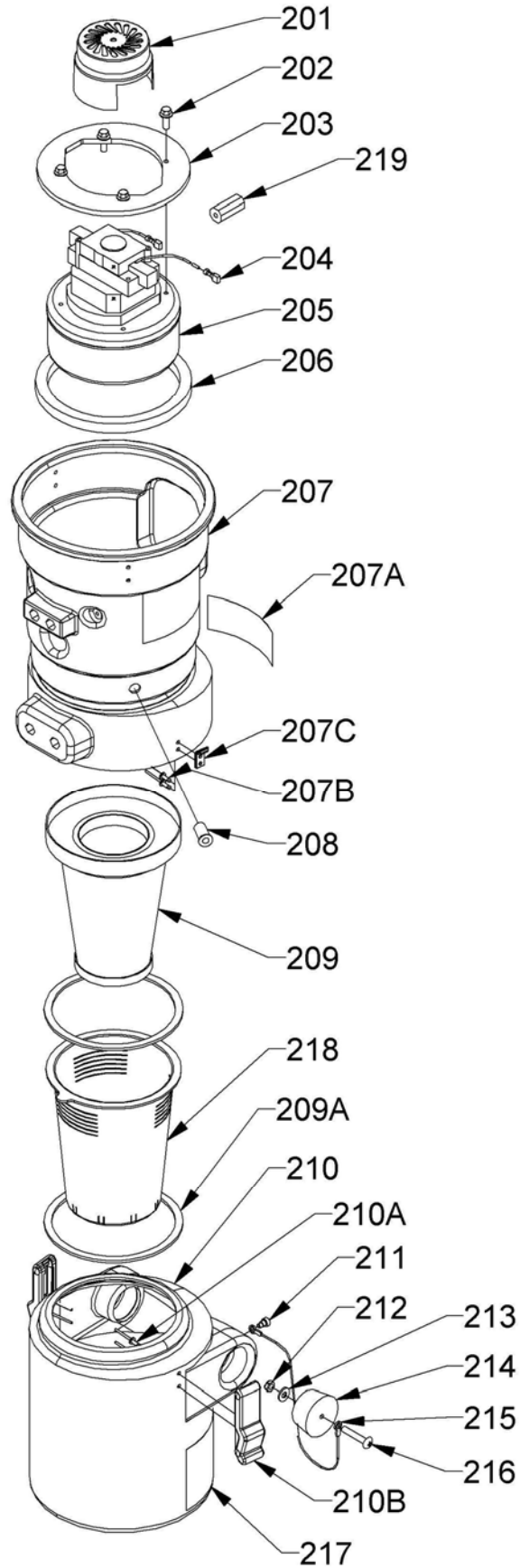

## TRIGGER AND HOSE ASSEMBLY

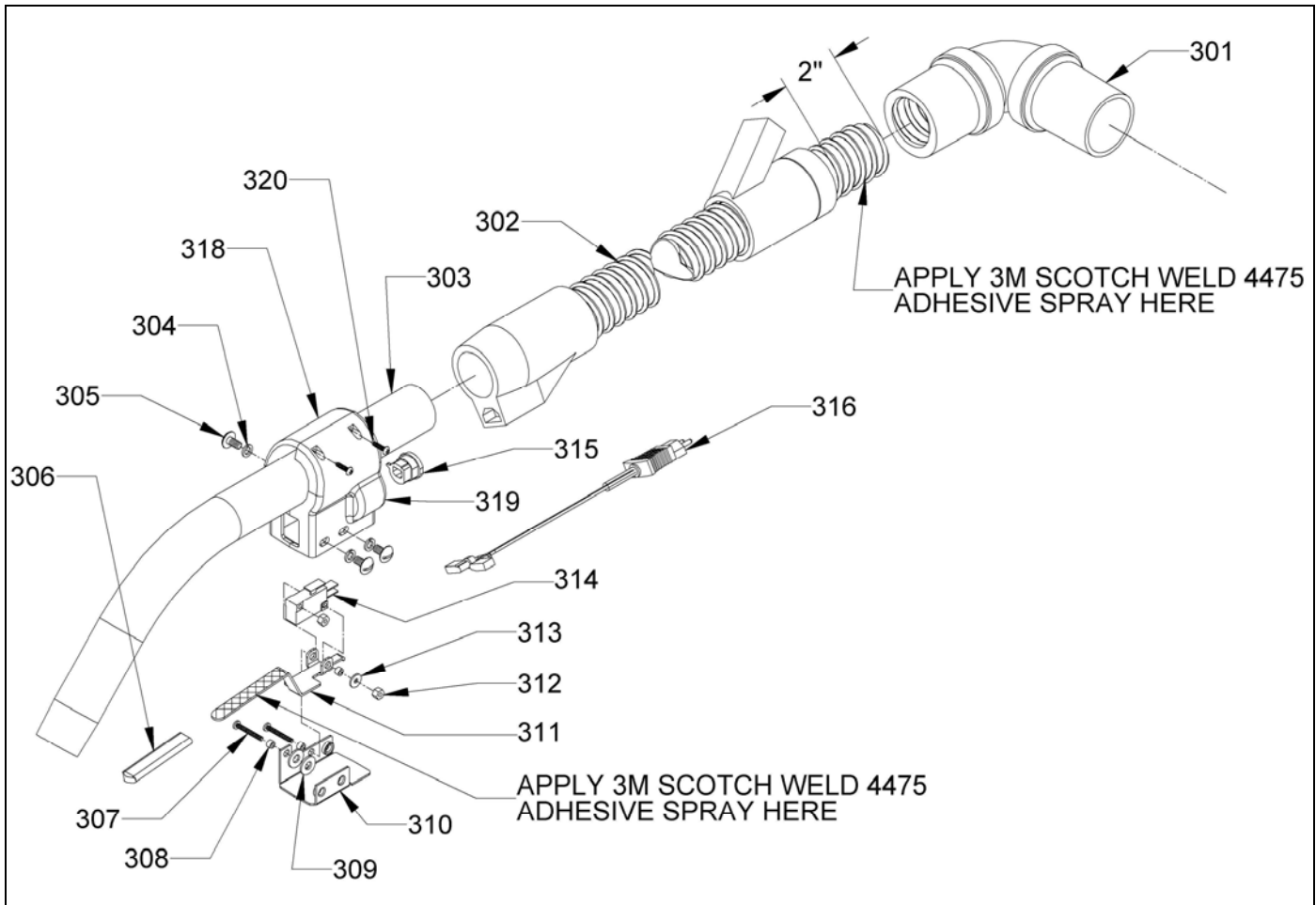

<u>ITEM</u>	<u>PART NO.</u>	<u>DESCRIPTION</u>	<u>QTY.</u>
301	6990751	CUFF - 90° 1 1/2 X 1 ¼	1
302	6990091	ELECTRIC HOSE - 1 1/4" I.D. - INCLUDES CUFF AT TRIGGER END	1
	6991351	TRIGGER ASSEMBLY, INCLUDES:	1
303	6991321	TUBE, WAND	1
304	9120320	#10 SPLIT LOCK WASHER	3
305	9120500	#10-24 X 3/8 TRUSS HEAD PHILLIPS MACHINE SCREW - PACK OF 10	3
306	6990341	TRIGGER COVER	1
307	9120014	#4-40 X 7/8 PAN HEAD PHILLIPS SCREW - PACK OF 10	2
308	6990071	#4 I.D. X 3/16 O.D. X 1/8 SPACER	3
309	9120370	7/32 I.D. X 1/2 O.D. FLAT WASHER (#10) - PACK OF 10	2
310	6990031	TRIGGER AND SWITCH MOUNT BRACKET	1
311	6990021	TRIGGER	1
312	9120010	4-40 HEX NUT WITH NY-LOK INSERT - PACK OF 5	2
313	9120016	#4 FLAT WASHER - PACK OF 10	1
314	6990041	10-AMP MOMENTARY SWITCH	1
315	6991371	STRAIN RELIEF	1
316	6990311	PIGTAIL - HOSE TO TRIGGER	1
317	6990869	CANISTER ASSEMBLY (NOT SHOWN)	1
318	6991301	TRIGGER HOUSING, RIGHT	1
319	6991291	TRIGGER HOUSING, LEFT	1
320	6991341	M2.9 X 14mm SELF TAPPING SCREW	2

## **BACK PACK HARNESS, BATTERIES & TOOLS**

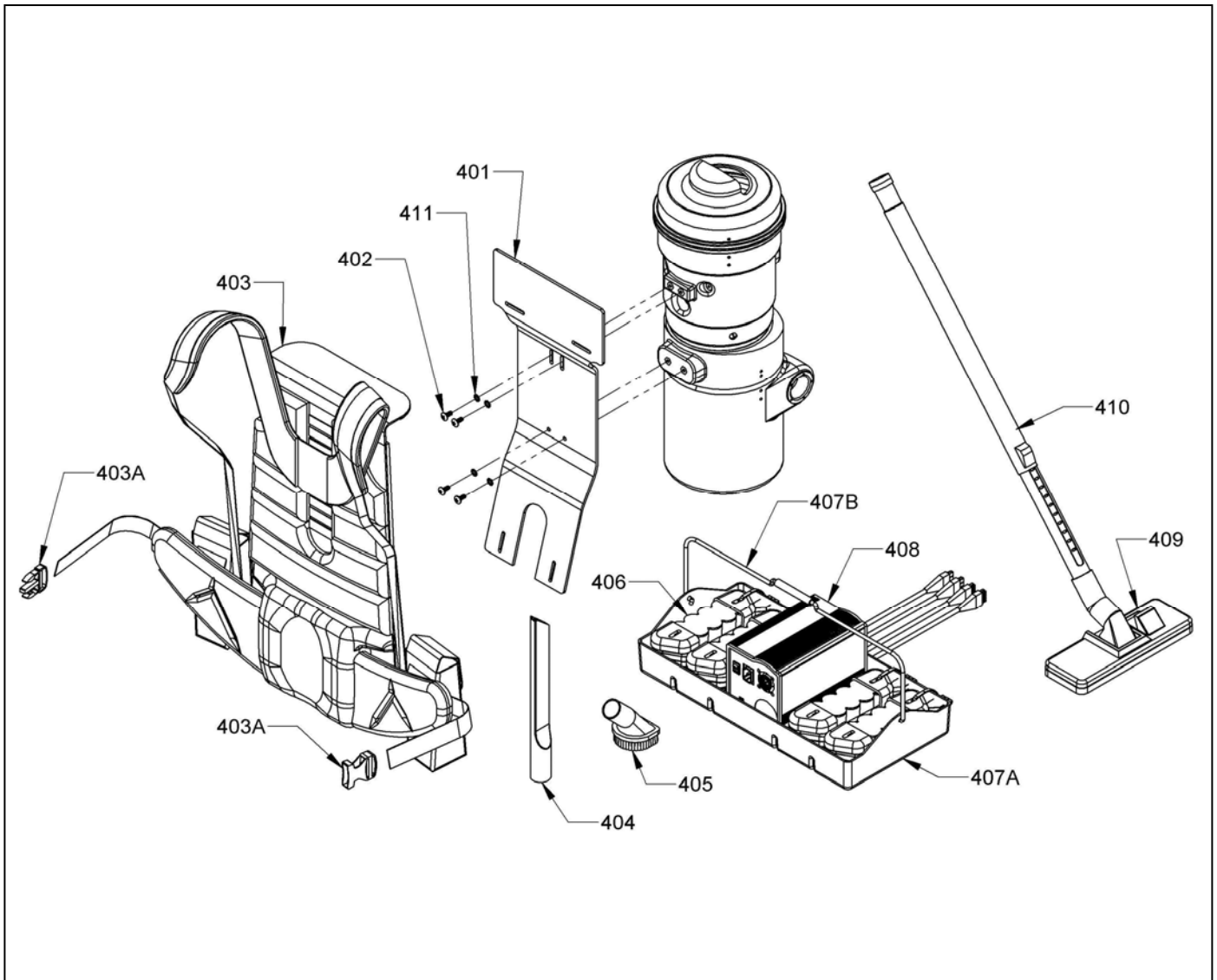

<b>ITEM</b>	<b>PART NO.</b>	<b>DESCRIPTION</b>	<b>QTY.</b>
401	6990581	BACK PACK ATTACHMENT PLATE	1
402	9121000	1/4-20 X 5/8 TRUSS HEAD PHILLIPS MACHINE SCREW - PACK OF 5	4
403	6990621	BACKPACK HARNESS - INCLUDES:	1
403A	6990911	BUCKLE - 1 1/2"	1
403B	6990941	REPLACEMENT BATTERY POCKET	2
404	6990491	CREVICE TOOL	1
405	6990541	ROUND BRUSH TOOL	1
406	6990501	BATTERY - NI-MH 9.5 AH "D" SIZE 13.2V - 2 BATTERIES NEEDED FOR	4
	6991179	BATTERY AND CHARGER TRAY ASSEMBLY - INCLUDES:	1
407A	6990521	BATTERY TRAY	1
407B	6990561	BATTERY TRAY HANDLE	1
408	6990511	BATTERY CHARGER - CHARGES UP TO 4 BATTERIES - INCLUDES	1
408A	6991141	CORD - 120 VAC - NOT SHOWN	1
409	6990471	COMBINATION FLOOR TOOL - 1 1/4	1
410	6990461	RETRACTABLE ALUMINUM WAND - 1 1/4	1
411	9120970	1/4" EXTERNAL STAR LOCK WASHER - PACK OF 10	4

## WIRE DIAGRAM - VACUUM ONLY

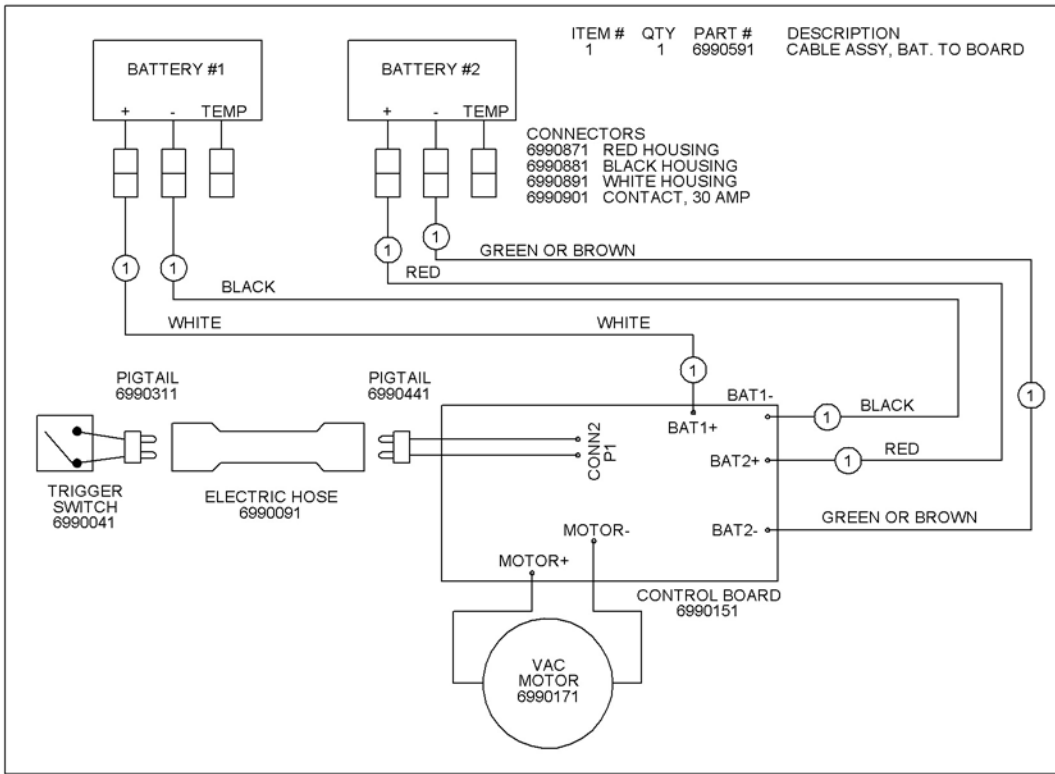

### ACCESSORIES



ITEM	PART NO.	DESCRIPTION	QTY
501	6990791	TRASH CAN ACCESSORY SKIRT	1
502	6990781	TRASH CAN MOUNT HANGER	2
503	6990801	OUTLAW PB HOSE, 1 1/4 I.D. X 10'	1

Trash can not available from NSS. Contact your local JanSan Distributor



### NSS® Enterprises, Inc.

3115 Frenchmens Road  
 Toledo, Ohio 43607  
 PHONE (419) 531-2121  
 FAX (419) 531-3761

[mailus@nss.com](mailto:mailus@nss.com)  
[www.nss.com](http://www.nss.com)