

PARTS LIST

MUSTANG 300 DS

FLOOR MACHINE

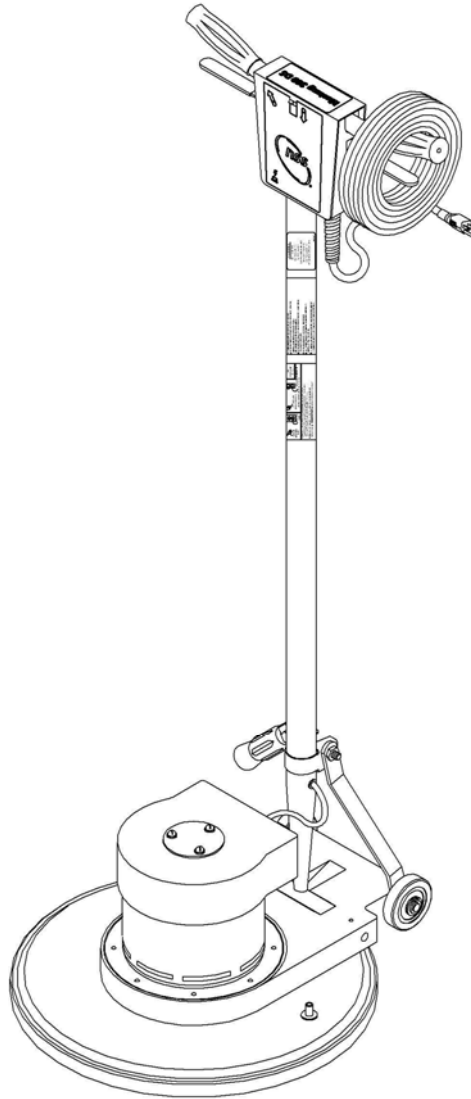

SAVE THESE INSTRUCTIONS



HANDLE ASSEMBLY

<u>ITEM</u>	<u>PART NO.</u>	<u>DESCRIPTION</u>	<u>QTY</u>
	5492549	HANDLE ASSEMBLY - 120 VOLT - MUSTANG 300 DS	1
	5492619	HANDLE ASSEMBLY - 240 VOLT - MUSTANG 300 DS	1
101	5392311	LABEL - "SWITCH BOX WITH CIRCUIT BREAKER ICON	1
102	0393511	LOCKOUT BRACKET	1
103	0393521	LOCK OUT	1
104	9120828	1/8 X 1 3/4 ROLL PIN – PACK OF 4	2
105	5390171	SWITCH LEVER SPRING	2
106	0393411	GRIP - SWITCH LEVER	2
107	0393401	SWITCH LEVER	1
108	5391321	WIRE NUT - ORANGE - 120 VOLT ONLY	1
109	0294031	#8 RING TERMINAL, INSULATED, 16-14 AWG	1
110	9120100	#6-32 X 1 ROUND HEAD PHILLIPS MACHINE SCREW – PACK OF 10	2
111	9120130	#6 EXTERNAL STAR LOCK WASHER – PACK OF 10	2
112	5390211	SWITCH	1
113	5390361	SWITCH INSULATOR	1
114	9120380	#10-24 X 3/8 ROUND HEAD PHILLIPS MACHINE SCREW – PK OF 10	1
115	9120320	#10 SPLIT LOCK WASHER – PACK OF 10	1
116	0298981	#10 RING TERMINAL 14-16 AWG	1
120	5391891	HANDLE	1
121	5490451	CIRCUIT BREAKER LEAD - 4"	1
122	9120360	#10-24 HEX NUT WITH STAR LOCK WASHER – PACK OF 10	2
124	5490401	20-AMP CIRCUIT BREAKER - 120 VOLT ONLY	1
	5294581	8-AMP CIRCUIT BREAKER - 240 VOLT ONLY	1
125	9120430	#10-24 X 3/4 ROUND HEAD PHILLIPS MACHINE SCREW – PK OF 10	2
126	5490441	INSULATION - BREAKER LEAD	1
127	9120200	#8 SPLIT LOCK WASHER – PACK OF 10	1
128	9120223	#8-32 X 1/4 PAN HEAD PHILLIPS MACHINE SCREW – PACK OF 5	1
129	5390511	FOAM PAD	1
130	5090441	NYLON BUSHING	2
131	5492621	HANDLE CORD	1
132	5293131	GROMMET	1
133	5091561	CORD 50 FEET 14-3 - 120 VOLT ONLY	1
	0299671	SHUKO CORD - 75 FEET - 16-3 - 240 VOLT ONLY	1
134	9120080	#6-32 X 3/4 RND HD PHILLIPS MACHINE SCR - 240V ONLY – PK OF 10	1
135	5391931	TERMINAL BLOCK - 240 VOLT ONLY	1
136	5391921	WIRE - GROUND - 240 VOLT ONLY	1
137	5391911	WIRE - DEAD MAN - 240 VOLT ONLY	1
138	5091671	STRAIN RELIEF - 120 VOLT ONLY	1
	0299531	STRAIN RELIEF - 240 VOLT ONLY	1
139	5390261	STRAIN RELIEF NUT - 120 VOLT ONLY	2
	0891131	STRAIN RELIEF NUT - 240 VOLT ONLY	1
140	5092371	STRAIN RELIEF CORD CLAMP - 120 VOLT ONLY	1
	0299861	STRAIN RELIEF CORD CLAMP - 240 VOLT ONLY	1
141	9122110	3/8 I.D. X 1 1/2 FENDER WASHER – PACK OF 10	1
142	5095501	CORD CLAMP	1
143	8791070	VINYL HOSE- CUT TO 2 3/16" LONG	0.18'
144	9120025	#6-32 DOUBLE HOLE SWITCH SPEED NUT – PACK OF 1	1
145	0393441	HANDLE GRIP	2
146	9120320	#10 SPLIT LOCK WASHER – PACK OF 10	1
147	9120380	#10-24 X 3/8 ROUND HEAD PHILLIPS MACHINE SCREW – PK OF 10	1
148	0393381	SPRING	1
149	0393881	M3 X .05 X 8mm PAN HEAD PHILLIPS THREAD CUTTING SCREW	2

HANDLE ASSEMBLY

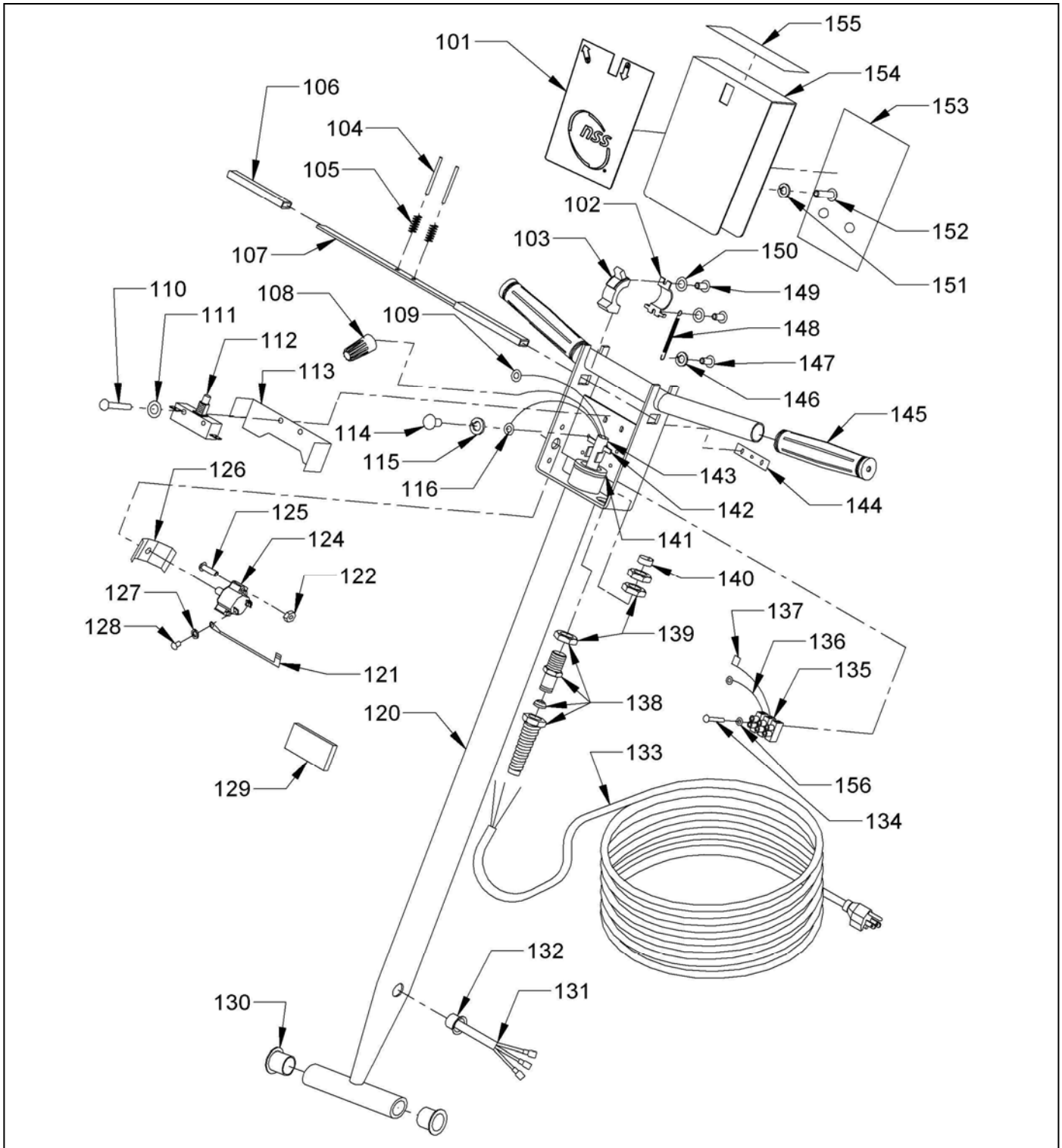

<u>ITEM</u>	<u>PART</u>	<u>DESCRIPTION</u>	<u>QTY</u>
150	9120130	#6 EXTERNAL STAR LOCK WASHER – PACK OF 10	2
151	9120320	#10 SPLIT LOCK WASHER – PACK OF 10	1
152	9120430	#10-24 X 3/4 ROUND HEAD PHILLIPS MACHINE SCREW – PK OF 10	1
153	0190681	SAFETY LABEL	1
154	5391873	SWITCH BOX COVER	1
155	5991911	IDENTIFIER DECAL - MUSTANG 300DS	1
156	9120130	#6 EXTERNAL STAR LOCK WASHER – PACK OF 10 – 240 VOLT ONLY	1

BASE ASSEMBLY

<u>ITEM</u>	<u>PART</u>	<u>DESCRIPTION</u>	<u>QTY</u>
201	9120730	#10-32 X 1/2 ROUND HEAD PHILLIPS MACHINE SCREW – PK OF 10	3
202	9120320	#10 SPLIT WASHER – PACK OF 10	3
203	5492523	PLATE WASHER	1
204	5492501	MOTOR COVER	1
205	5992011	MOTOR AND GEAR 115V, MUSTANG 300 DS	1
		MOTOR ONLY - 120 VOLT - 1 1/2 HP	1
207	5992081	GEARBOX W/ENDSHIELD & FLEX COUPLING	1
205	5992021	MOTOR AND GEAR 240V, MUSTANG 300 DS	1
		MOTOR ONLY - 240 VOLT - 1 1/2 HP	1
207	5992081	GEARBOX W/ENDSHIELD & FLEX COUPLING	1
208	9120850	1/4-20 X 5/16 SET SCREW - KNURL POINT – PACK OF 2	2
209	5390013	BASE	1
210	5390883	SKIRT – 17”	1
	5390873	SKIRT - 20”	1
211	9121390	11/32 I.D. X 11/16 O.D. X .051/.080 THICK FLAT WASHER (5/16) – PK OF 10	4
212	9121520	5/16 SPLIT LOCK WASHER – PACK OF 10	4
213	9121510	5/16-18 X 2 1/4 SOCKET HEAD CAP SCREW – PACK OF 2	4
214	5092641	RETAINING RING	1
215	5990331	3/8” I.D. “0” RING	1
216	5390861	BUMPER - 17”	1
	5390851	BUMPER - 20”	1
217	5390496	HANDLE PIVOT BAR	1
218	5092641	RETAINING RING	1
219	5990241	SOLUTION FEED TUBE	1
220	5091691	RUBBER PAD	4
221	0393321	HANDLE GRIP	1
222	9121680	5/16-18 X 1 HEX BOLT – PACK OF 5	1
223	5390043	TUBE CLAMP	1
224	5390136	AXLE	1
225	9122705	1/2 I.D. X 3/4 O.D. X .01 THICK - 1 WAVE SPRING WASHER (1/2) – PK OF 2	2
227	9122496	RETAINING RING – PACK OF 8	2
228	9122465	.516 I.D. X .813 O.D. X .027/.030 THICK FLAT WASHER – PACK OF 2	2
229	5092591	WHEEL - 5” - WITH PLASTIC BEARING	2
230	9122705	1/2 I.D. X 3/4 O.D. X .01 THICK - 1 WAVE SPRING WASHER (1/2) – PK OF 2	1
231	5390811	1/2 I.D. X 1 O.D. X .07 THICK FLAT WASHER – NYLATRON	2
232	5390026	HANDLE BRACE	2
233	9122140	3/8-16 HEX NUT WITH NY-LOK INSERT – PACK OF 5	1
234	5390826	TUBE CLAMP SHOE	1
235	5391891	HANDLE	1
236	5390201	RUBBER TUBING	1
237	0393141	FLATTENED CLAMP BOLT	1
238	0393131	SLOTTED WASHER	1
239	9121450	5/16-18 HEX NUT WITH NYLOK INSERT– PACK OF 5	1
240	0393121	CLAMP LEVER	1
241	5492601	JUMPER WIRE / SWITCH	1
242	5990231	FULLY INSULATED MALE TERMINAL 14-16 AWG	1
243	5490161	FULLY INSULATED FEMALE TERMINAL 14-16 AWG	1
244	5490171	FULLY INSULATED MALE TERMINAL 14-16 AWG	2
245	5492531	LABEL - “HI SPEED / LOW SPEED”	1
246	4991841	HIGH / LOW SPEED SWITCH WITH SPLASH GUARD	1

BASE ASSEMBLY

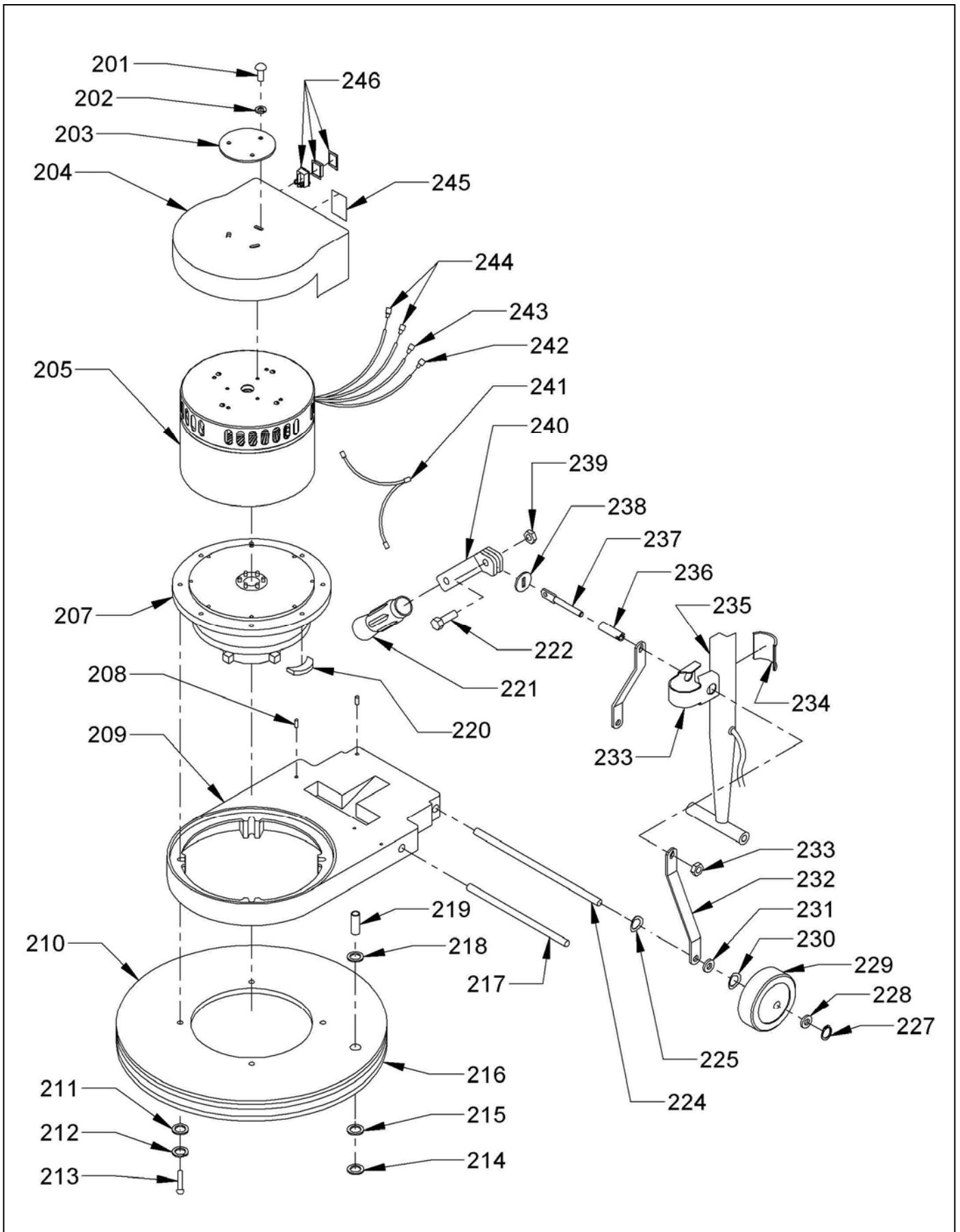

MOTOR ASSEMBLY

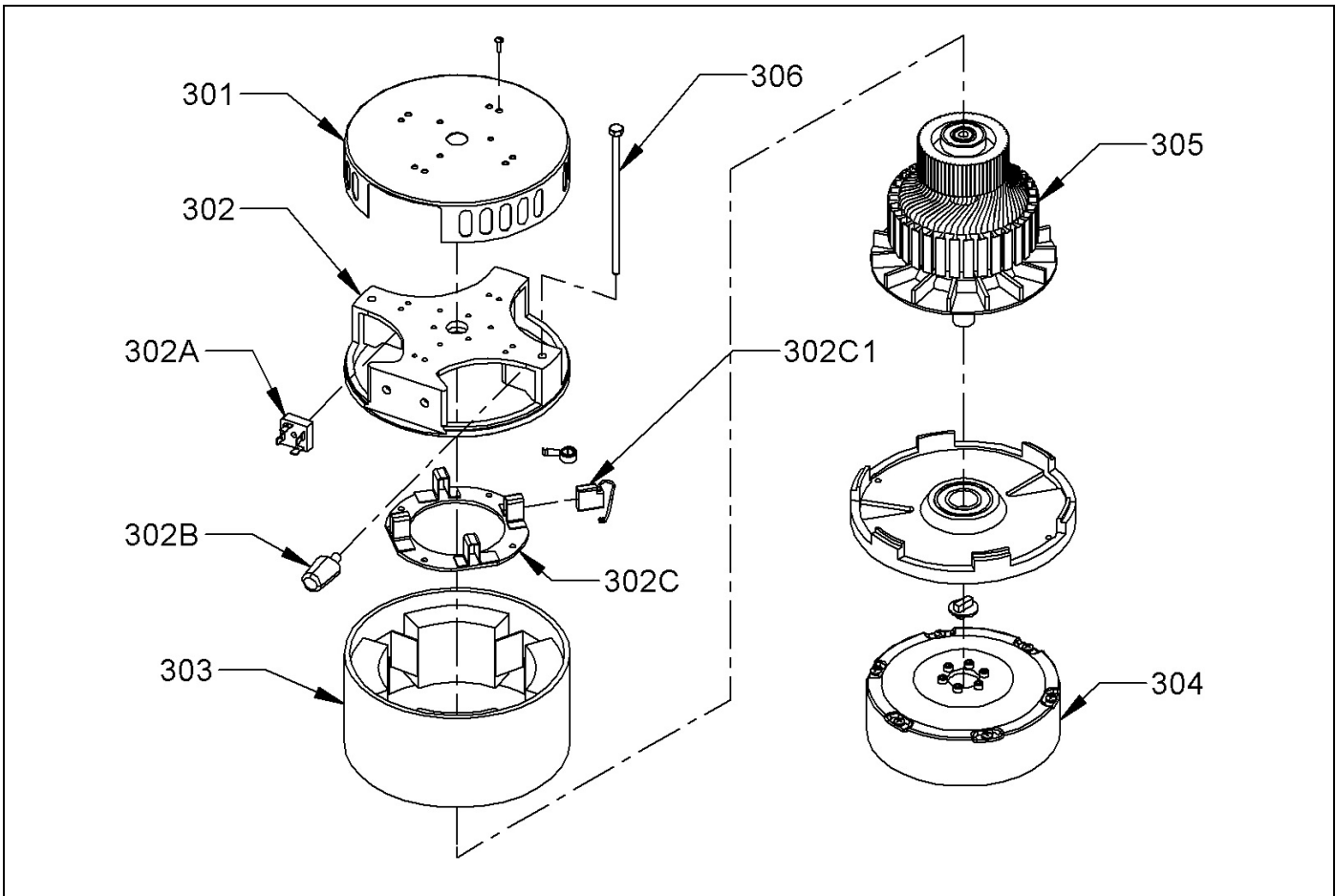

ITEM	PART NO.	DESCRIPTION	QTY.
301	5992181	COMMUTATOR BRACKET COVER	1
302	5992051	COMMUTATOR BRACKET ASSEMBLY - 115 VOLT	1
	5992061	COMMUTATOR BRACKET ASSEMBLY - 240 VOLT	1
302	5992111	COMMUTATOR BRACKET - 115 & 240 VOLT	1
302A	5492741	RECTIFIER - 115 VOLT	1
	5992121	RECTIFIER - 240 VOLT	1
302B	5992091	SPEED CONTROL - 115 VOLT	1
	5992101	SPEED CONTROL - 240 VOLT	1
302C	5991611	BRUSH BOARD ASSEMBLY (W/BRUSHES & SPRINGS) - 115 VOLT	1
302C1	5293651	BRUSH FOR 5992011 - 115 VOLT	4
302C	5992071	BRUSH BOARD ASSEMBLY (W/BRUSHES & SPRINGS) - 240 VOLT	1
302C1	5992151	BRUSH FOR 5992021 - 240 VOLT	4
303	5992171	STATOR ASSEMBLY - 115 & 240 VOLT	1
304	5992081	GEARBOX W/ENDSHIELD & FLEX COUPLING	1
305	5992031	ARMATURE ASSEMBLY - 115 VOLT	1
	5992041	ARMATURE ASSEMBLY - 240 VOLT	1
306	-----	MOTOR BOLTS	2

WIRE DIAGRAM – MUSTANG 300 DS

WIRING DIAGRAM - MUSTANG 300 DS - 120 VOLT

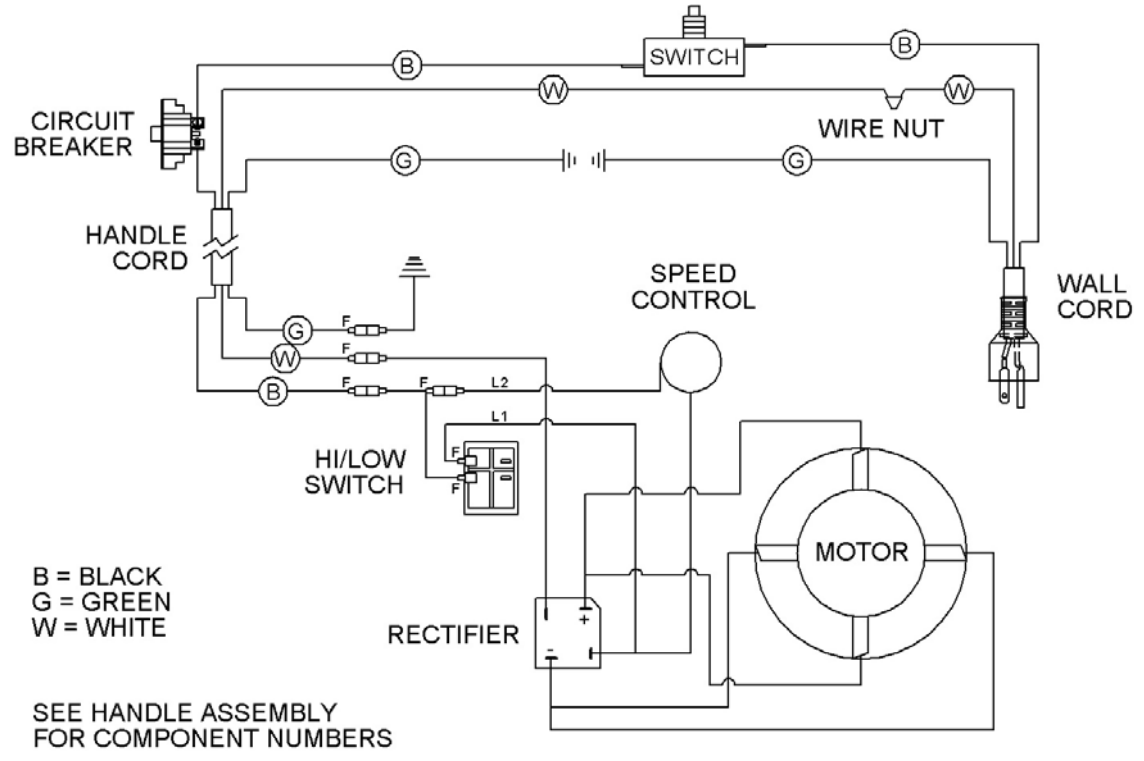

WIRING DIAGRAM - MUSTANG 300 DS - 240 VOLT

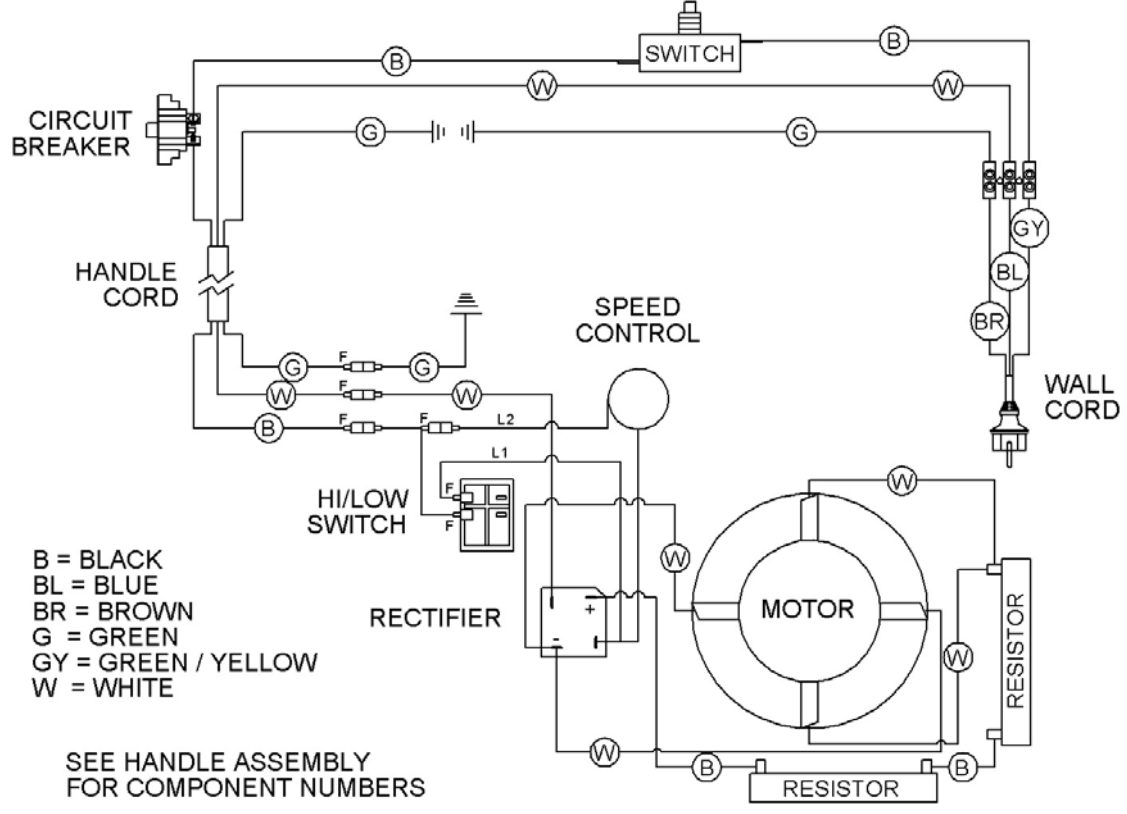

ACCESSORIES



- 2890101 PLASTIC CLUTCH PLATE - 5" DIAMETER - 6 HOLES
- 2890981 ALUMINUM CLUTCH PLATE - 4" DIAMETER - 3 HOLES
- 2890991 ALUMINUM CLUTCH PLATE - 5" DIAMETER - 6 HOLES
- 2893001 PLASTIC CLUTCH PLATE - 4" DIAMETER - 3 HOLES



- 2897551 17" H.S. PAD DRIVER (DS MACHINE)
- 2897211 17" POLY BACK TUFTED PAD DRIVER
- 2897601 17" STRUCTURAL FOAM PAD DRIVER
- 2897201 17" POLY BACK NYLON FILL SCRUB BRUSH - LIGHT TO MEDIUM SCRUB
- 2897711 17" POLY BACK NYLON GRIT FILL SCRUB BRUSH - HEAVY CONCRETE SCRUB
- 2897821 17" POLY BACK NYLON - SOFT SCRUB BRUSH - CARPET ONLY
- 2897901 17" POLY BACK SCRUB GRIT BRUSH - MILD TO MEDIUM SCRUB

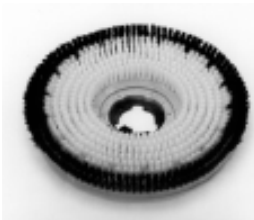

- 2892551 20" H.S. PAD DRIVER (DS MACHINE)
- 2892211 20" POLY BACK TUFTED PAD DRIVER
- 2892601 20" STRUCTURAL FOAM PAD DRIVER
- 2892201 20" POLY BACK NYLON FILL SCRUB BRUSH - LIGHT TO MEDIUM SCRUB
- 2892651 20" POLY BACK NYLON FILL SCRUB BRUSH - WITH GUIDE FOR CARPET SHAMPOOING
- 2892711 20" POLY BACK NYLON GRIT FILL SCRUB BRUSH - HEAVY CONCRETE SCRUB
- 2892031 20" PLASTIC BACK BASSINE SCRUB BRUSH - GENERAL SCRUB
- 2892701 20" POLY BRUSH - SHOWER FEED - STANDARD CARPET SCRUB
- 2892901 20" POLY BACK SCRUB GRIT BRUSH - MILD TO MEDIUM SCRUB

NOTE: ALL PADS COME 5 PADS PER CASE

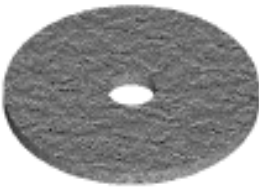

- 7991751 17" LITE BLUE POLISH/BURNISH PAD - SOFT FINISH
- 7991741 17" UHS CLEAN BUFF PAD - REMOVE SCUFF MARKS NOT FINISH
- 7991731 17" BLUE SCRUB PAD - TOP SCRUB AND LIGHT FINISH REMOVAL
- 7991721 17" GREEN SCRUB PAD - HEAVY FINISH REMOVAL
- 7991701 17" BLACK STRIP PAD - REMOVES FINISH COMPLETELY

- 7992031 20" BLUE SCRUB PAD - TOP SCRUB AND LIGHT FINISH REMOVAL
- 7992001 20" BLACK STRIP PAD - REMOVES FINISH COMPLETELY
- 7992011 20" BROWN STRIP PAD - REMOVES FINISH COMPLETELY



- 5094771 DELUXE SOLUTION TANK - 3.5 GALLON WITH BRASS VALVES



NSS® Enterprises, Inc.

3115 Frenchmens Road
 Toledo, Ohio 43607
 PHONE (419) 531-2121
 FAX (419) 531-3761
mailus@nss.com
www.nss.com