

Micromax™ 17E

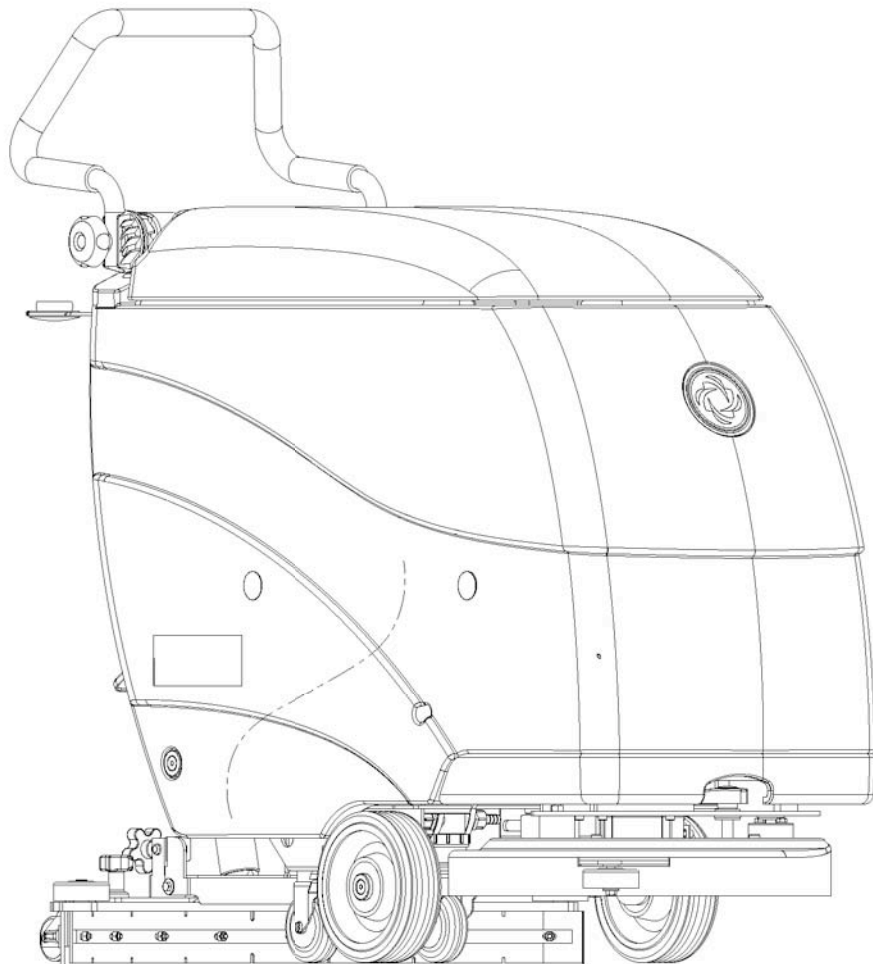

PARTS LIST

Advance model: 908 7047 020

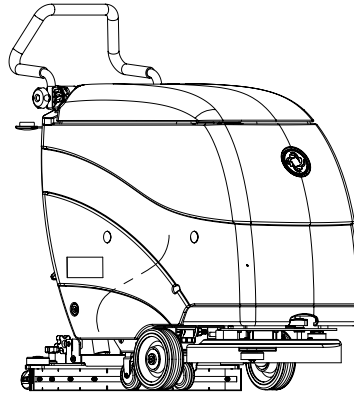

Advance
by Nilfisk-Advance

**DESCRIPTION****PLAN**

GENERAL VIEW	2 - 3
TANK SYSTEM	4 - 5
CHASSIS SYSTEM	6 - 7
SOLUTION SYSTEM	8 - 9
SQUEEGEE ASSEMBLY	10 - 11
BRUSH SYSTEM	12 - 13
CONTROL PANEL SYSTEM	14 - 15
WIRING SYSTEM	16 - 17
WIRING DIAGRAM	18
RECOMMENDED SPARE PARTS	19

WHEN ORDERING PARTS

- * Use the 8,9 or 10 digit part numbers from the "Ref. No." columns in this parts list.
- * Specify the model and serial number of the machine.
- * Use the space below to record the model and the serial number for future reference.

Model _____ Serial No. _____

**= *Optional*

= *New Item no.*

[] = *Not shown*

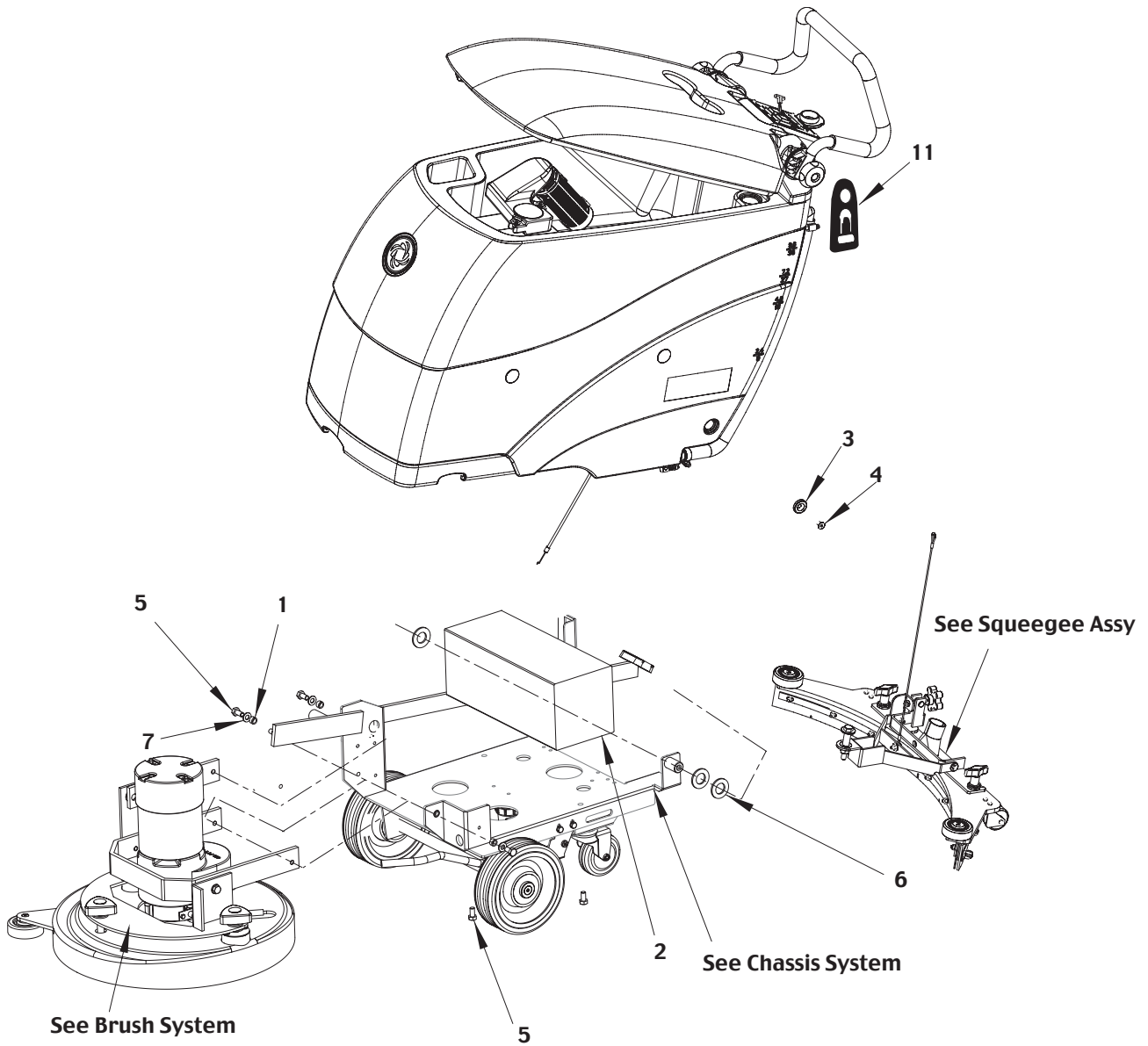

2005-01	GENERAL VIEW		
2004-06	MICROMAX™ 17E		3

Item no.	Ref. No.	Qty	Description
1	xxxxxxx	3	Bushing 8.1x12x6.5
2#	L08812927	1	Weight
3	xxxxxxx	2	Spacer
4	xxxxxxx	2	Screw M8x12
5	xxxxxxx	5	Screw hex hd M8x16
6	xxxxxxx	2	Washer flat 20.5x37 nylon
7	xxxxxxx	3	Washer flat 8x17
[10]	909 5687 000	1	Kit decals Micromax™ 17E(Decal Advance Micromax™,Decal Nilfisk Logo, Decal brush adjusting, Decal brush inc.adjusting, Decal water faucet, Decal warning)
11	56340079	1	Cable holder
[12]#	L08603955	1	General Hardware kit (1,3,4,5,6,7)

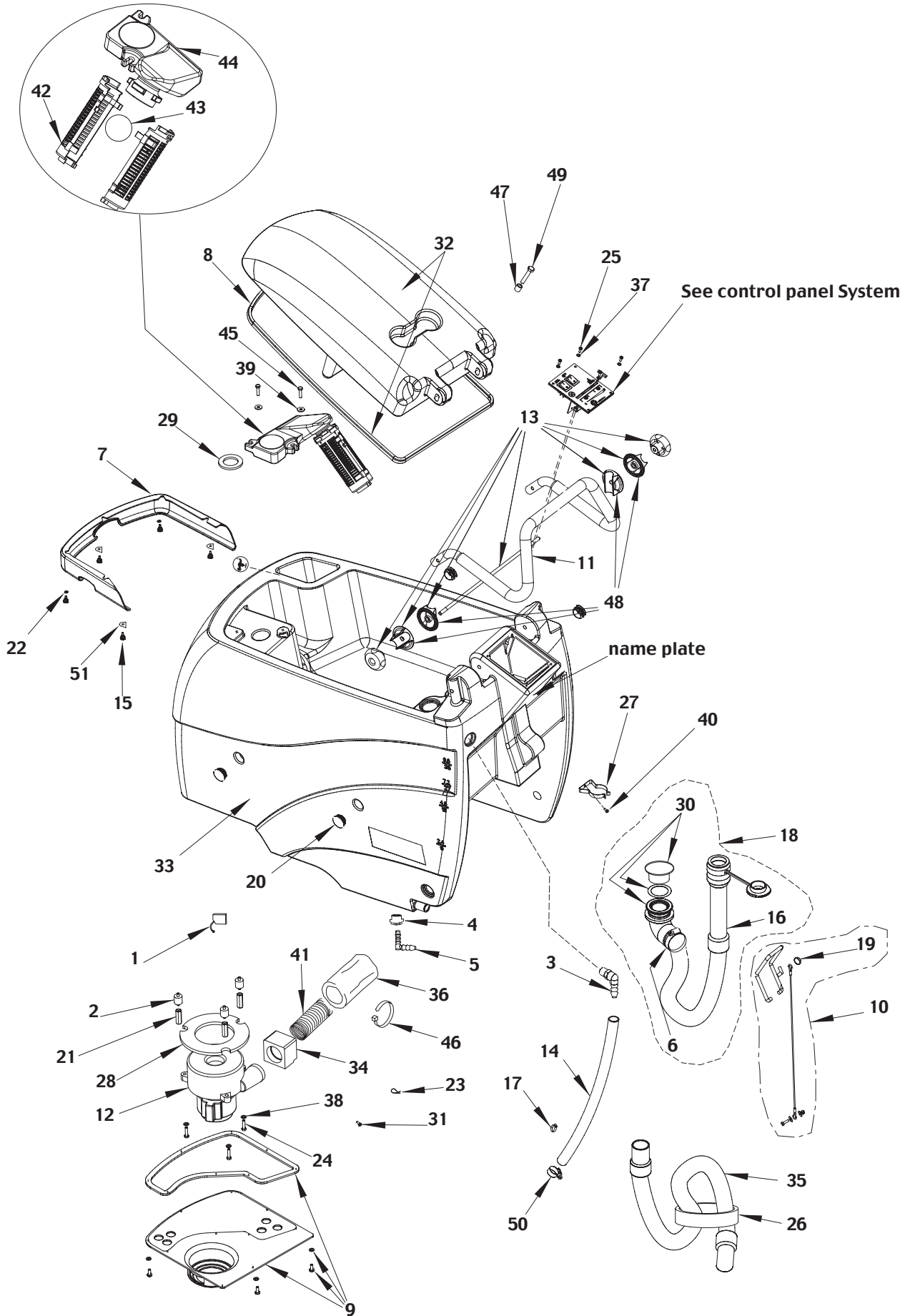

2005-01	TANK SYSTEM			
2004-06	MICROMAX™ 17E			5

Item no.	Ref. No.	Qty	Description
1	909 5697 000	1	Carbon brush kit (2 pcs)
2	56325553	3	Buffer
3	56264442	1	Elbow 90°
4	909 5286 000	1	Gasket ø10
5	909 5285 000	1	Elbow 90° ø10 nylon
6	xxx xxxx xxx	1	Clamp (Drain hose complete)
7a	909 5423 000	1	Bumper front before serial no 1763708
7b	909 5717 000	1	Bumper front after serial no 1763708
8	146 0741 000	1	Gasket tank cover
9	909 5439 000	1	Kit acoustic cover cpl
10#	L08603970	1	Squeegee lifting lever kit (19)
11	909 5422 000	1	Handle bar
12#	L08812848	1	Kit vacuum motor w/ connector
13#	L08603860	1	Handle adjuster kit (48)
14	909 5420 000	1	Solution hose
15	909 5835 000	5	Handwheel M5x10
16#	L08812869	1	Drain hose (Drain hose complete)
17	xxx xxxx xxx	1	Clamp
18#	L08812873	1	Drain hose complete (6, 16, 30)
19	xxxxxxx	1	Cap black (Squeegee lifting lever kit)
20#	L08812457	4	Tank locking cap
21	56325552	3	Spacer
22	145 9341 000	2	Washer flat 5x20 plated
23#	L08239900	3	Clamp grey
24	xxxxxxx	3	Screw hex hd M6x25
25	xxxxxxx	4	Screw cyl hd 4x14 thd forming
26	909 5246 000	1	Rubber band
27	xxxxxxx	1	Hose clamp ø50
28	56325551	1	Vacuum motor seal
29#	L08812968	1	Gasket
30#	L08812874	1	Kit elbow (Drain hose complete)
31	xxxxxxx	3	Screw oval HD M5x10
32	909 5440 000	1	Tank lid complete with gasket (8)
33	909 5417 000	1	Tank
34	56325520	1	Sleeve
35	909 5583 000	1	Flexible suction hose
36	145 8589 000	1	Acoustic insulation hose
37	xxx xxxx xxx	4	Washer flat 4x9 SS
38	xxxxxxx	3	Washer flat 6x12.5
39	xxxxxxx	2	Washer flat 6x18 SS
40	xxx xxxx xxx	1	Screw socket HD M5x12 SS
41	909 5688 000	1	Hose ø 38 L=240 mm
42	56324497	2	Float cage
43	56391690	1	Floating ball
44#	L08812926	1	Float cage holder
45	xxxxxxx	2	Screw pan hd phil 6x25 SS
46	xxx xxxx xxx	1	Clamp black 7.6x290
47#	L08812449	1	Spacer ø6x8x29
48	909 5099 000	1	Ratchet handle adjuster kit
49	xxxxxxx	1	Screw socket HD M6x8 SS
50	xxxxxxx	2	Clamp
51	909 5924 000	3	Plate
[52]#	L08603956	1	Tank system hardware kit (6,17,19,24,25,27,31,37,38,39,40,45,46,49,50)

7b Modification not interchangeable. Standardization of the bumper.

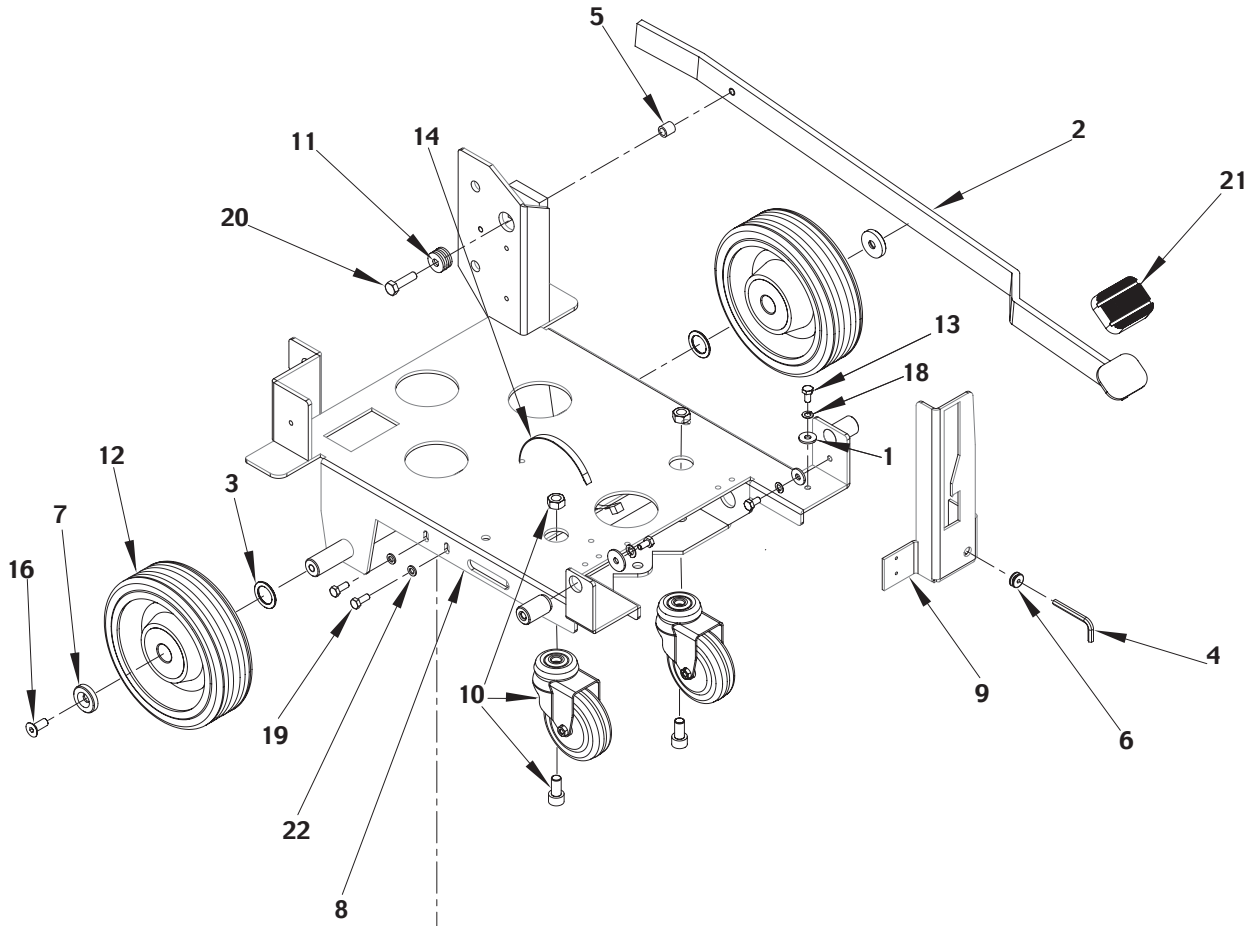

See Solution System

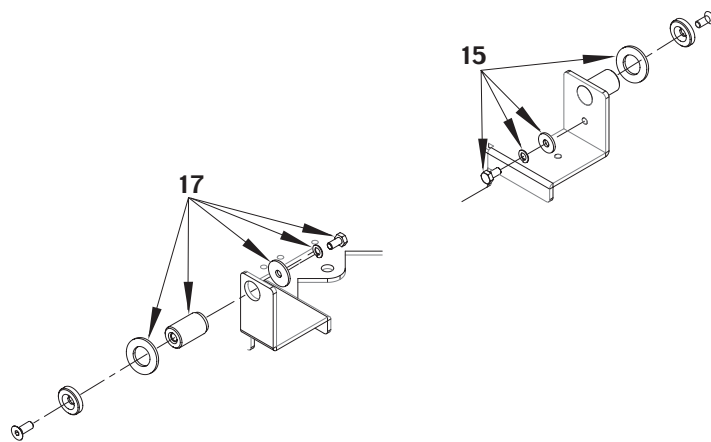

2005-01	CHASSIS SYSTEM		
2004-06	MICROMAX™ 17E		7

Item no.	Ref. No.	Qty	Description
1	xxxxxxx	2	Washer flat 6x18
2#	L08812925	1	Brush lifting pedal
3#	L08812936	2	Spacer
4	56325785	1	Allen wrench M5
5	56325586	1	Spacer ø 8x12x12.5
6	56325786	1	Grommet
7#	L08812392	4	Bushing
8	909 5152 000	1	Chassis
9#	L08812893	1	Brush pedal guide
10#	L08603861	2	Kit castor wheel rear
11	xxxxxxx	3	Washer flat
12#	L08812939	2	Front wheel
13	xxxxxxx	3	Screw hex hd M6x12
14	145 0524 000	6	Clamp black 4.8x200
15#	L08603862	1	Kit tank support right
16	xxx xxxx xxx	4	Screw M8x20
17#	L08603863	1	Kit tank support left
18	145 9228 000	2	Washer split 6
19	xxx xxxx xxx	2	Screw hex hd M6x16
20#	L08367300	1	Screw M8x25
21	145 8478 000	1	Pedal cover
22	xxx xxxx xxx	2	Washer flat 6x12.5
[23]	xxx xxxx xxx	2	Clamp 7,6x290
[24]#	L08603957	1	Chassis system hardware kit (1,11,13,16,19,22,23)

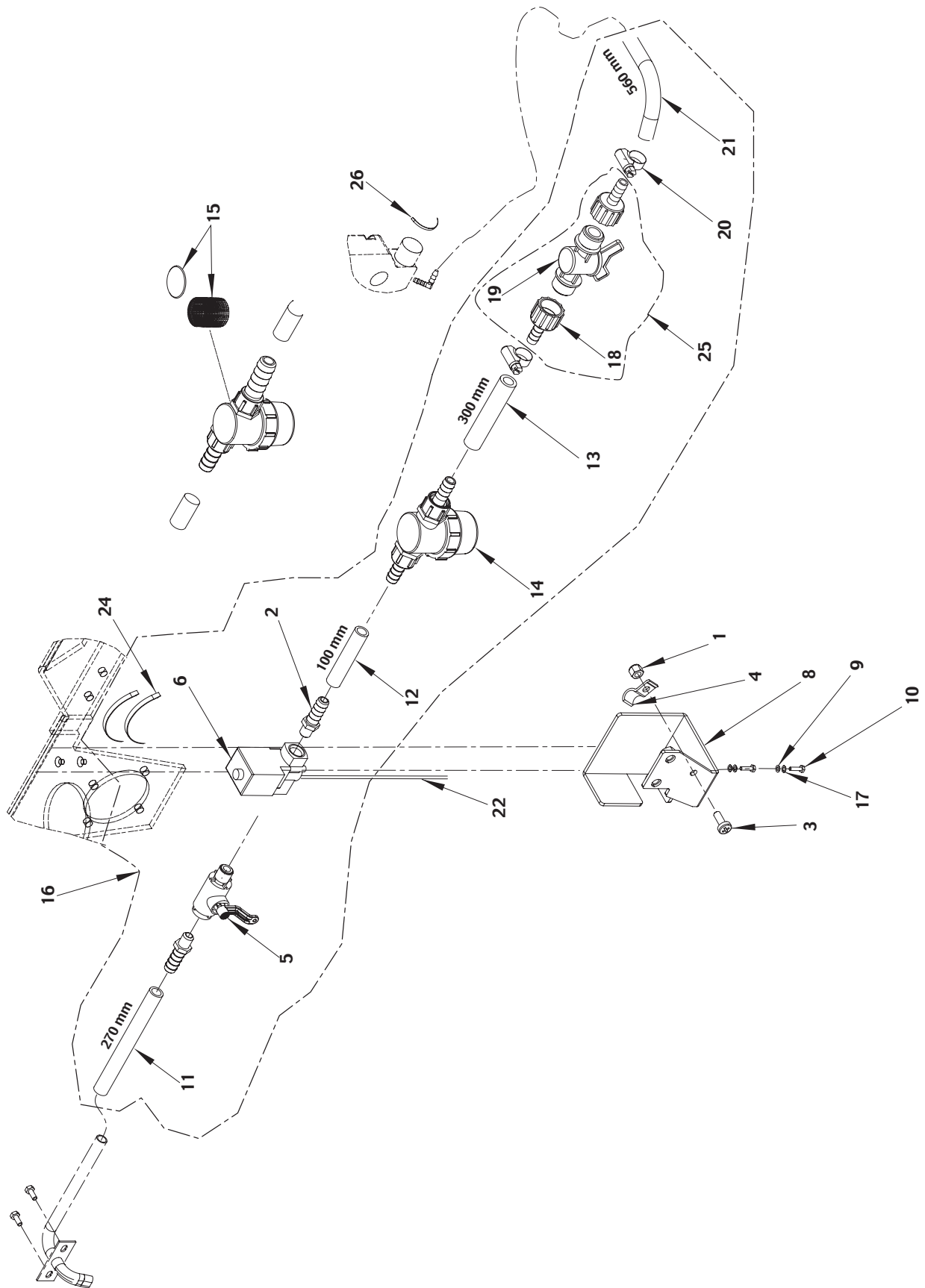

2005-01	SOLUTION SYSTEM		
2004-06	MICROMAX™ 17E		9

Item no.	Ref. No.	Qty	Description
1	xxxxxxx	1	Nut hex selflock low M6 (Solution System Hardware Kit)
2	xxxxxxx	2	Rubber holder (Solenoid valve kit complete)
3	xxx xxxx xxx	1	Screw hex hd M6x16 (Solution System Hardware Kit)
4	xxxxxxx	1	Clamp (Solution System Hardware Kit)
5	909 5627 000	1	Valve 1/4 solenoid valve (Solenoid valve kit complete)
6#	L08812959	1	Solenoid valve 110V (Solenoid valve kit complete)
8	xxxxxxx	1	Solenoid valve holder
9	xxxxxxx	2	Washer split 3 SS (Solution System Hardware Kit)
10	xxxxxxx	2	Screw hex hd M3x12 SS (Solution System Hardware Kit)
11#	L08603854	1	Hose ø10 270 mm (Solenoid valve kit complete)
12	909 5026 000	1	Hose ø10 100 mm (Solenoid valve kit complete)
13	909 5025 000	1	Hose ø10 300 mm (Solenoid valve kit complete)
14	909 5151 000	1	Water filter (Solenoid valve kit complete)
15#	L08603893	1	Kit net filter with gasket
16	909 5780 000	1	Solenoid valve kit complete (2,5,6,11,12,13,14,18,19,20,21,24,25)
17	xxxxxxx	2	Washer flat 3x9 SS (Solution System Hardware Kit)
18	xxx xxxx xxx	2	Pipe holder ø11 (Valve with pipe holder kit)
19	xxx xxxx xxx	1	Valve (Valve with pipe holder kit)
20	xxx xxxx xxx	4	Clamp 8/9-16 (Solenoid valve kit complete)
21#	L08603855	1	Hose ø10 560 mm (Solenoid valve kit complete)
22#	L08812956	1	Cable, solenoid valve complete with connector
[23]#	L08603885	1	Connector
24	xxx xxxx xxx	2	Clamp 4,8x200 (Solenoid valve kit complete)
25	909 5787 000	1	Valve with pipe holder kit [18,19] (Solenoid valve kit complete)
26	145 0541 000	1	Clamp
[27]#	L08603958	1	Solution System Hardware kit (1,3,4,9,10,17)

SQUEEGEE ASSEMBLY

2005-01

10

MICROMAX™ 17E

2004-06

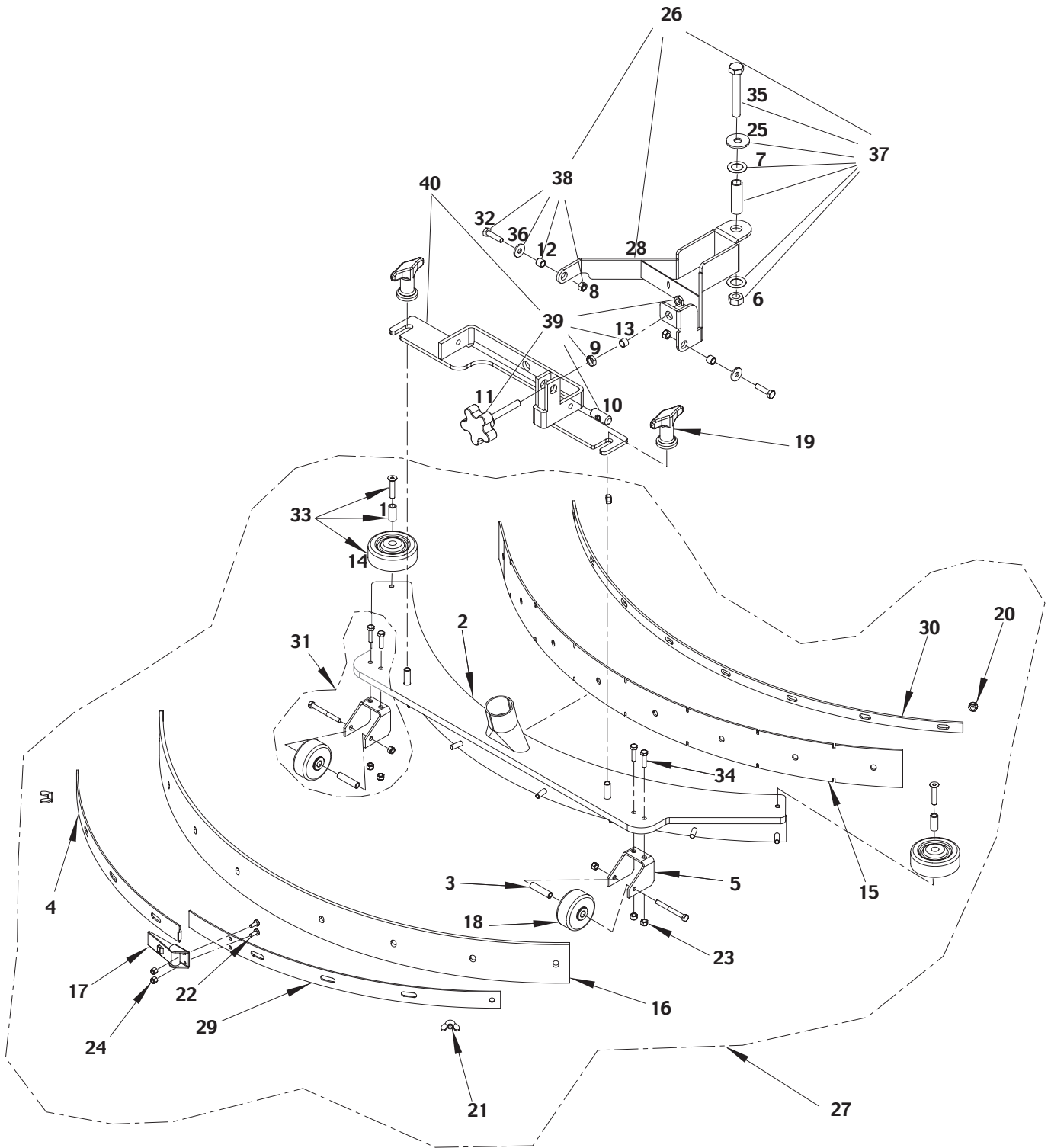

2005-01	SQUEEGEE ASSEMBLY			
2004-06	MICROMAX™ 17E			11

Item no.	Ref. No.	Qty	Description
1	xxxxxxx	2	Spacer \varnothing 6.3x9.5x21 (Kit squeegee complete)
2	xxxxxxx	1	Squeegee weldment (Kit squeegee complete)
3	xxxxxxx	2	Squeegee wheel spacer (Kit squeegee complete)
4	xxxxxxx	1	Rear f/squeegee latch strap (Kit squeegee complete)
5	xxxxxxx	2	Squeegee wheel bracket (Kit squeegee complete)
6	xxx xxxx xxx	1	Nut (Fixture kit)
7	xxxxxxx	2	Washer flat 15x25 nylon (Fixture kit)
8	xxxxxxx	2	Nut hex self lock low M6 (Fixture nozzle holder left/right kit)
9	xxxxxxx	2	Nut hex low M8 (Adjustment screw kit)
10	xxxxxxx	1	Support pin (Adjustment screw kit)
11	xxxxxxx	1	Handwheel M8x55 (Adjustment screw kit)
12	xxxxxxx	2	Spacer 7x10x8 (Fixture nozzle holder left/right kit)
13	xxxxxxx	1	Spacer 8x10x7 (Adjustment screw kit)
14	xxxxxxx	2	Roller bumper (Kit squeegee complete)
15	56393285	1	Squeegee blade front (Kit squeegee complete)
16	56325685	1	Squeegee blade rear (Kit squeegee complete)
17	xxxxxxx	1	Squeegee latch (Kit squeegee complete)
18	xxxxxxx	2	Squeegee wheel \varnothing 51 (Kit squeegee complete)
19#	L08603675	2	Squeegee fixing thumb nut
20	xxxxxxx	6	Nut hex selflock M6 SS (Kit squeegee complete)
21	xxx xxxx xxx	2	Wing nut M6 (Kit squeegee complete)
22	xxxxxxx	2	Screw M4x10 SS (Kit squeegee complete)
23	xxxxxxx	6	Nut hex self lock M5 SS (Kit squeegee complete)
24	xxxxxxx	2	Nut hex self lock M4 SS (Kit squeegee complete)
25	xxxxxxx	1	Washer flat 10x30 (Fixture kit)
26#	L08603877	1	Nozzle holder kit (28,37,38)
27#	L08603878	1	Kit squeegee complete (1, 2, 3, 4, 5, 14, 15, 16, 17, 18, 20, 21, 22, 23, 24, 29, 30, 31, 33, 34)
28	xxxxxxx	1	Squeegee holder bracket (Nozzle holder kit)
29	xxxxxxx	1	Rear w/hook strap (Kit squeegee complete)
30	xxxxxxx	1	Blade fixer strap (Kit squeegee complete)
31#	L08603879	1	Kit squeegee wheel (Kit squeegee complete)
32	xxxxxxx	2	Screw hex hd M6x25 (Fixture nozzle holder left/right kit)
33	xxxxxxx	1	Kit squeegee bumper roller (Kit squeegee complete)
34	xxxxxxx	4	Screw hex hd M5x20 SS (Kit squeegee complete)
35	xxx xxxx xxx	1	Screw hex hd M10x70 (Fixture kit)
36	xxxxxxx	2	Washer flat 6x18 (Fixture nozzle holder left/right kit)
37	56325681	1	Fixture kit (6,7,25,26,35)
38	56325682	1	Fixture nozzle holder left/right kit (8,12,32,36)
39	56325684	1	Adjustment screw kit (9,10,11,13)
40#	L08603876	1	Nozzle holder kit (39,40)
[41]#	L08603959	1	Squeegee assembly Hardware kit (6,7,8,9,21,22,23,24,25,32,34,35,36)
[42]#	L08603923	1	Bumper roller option kit

Micromax™ 17E

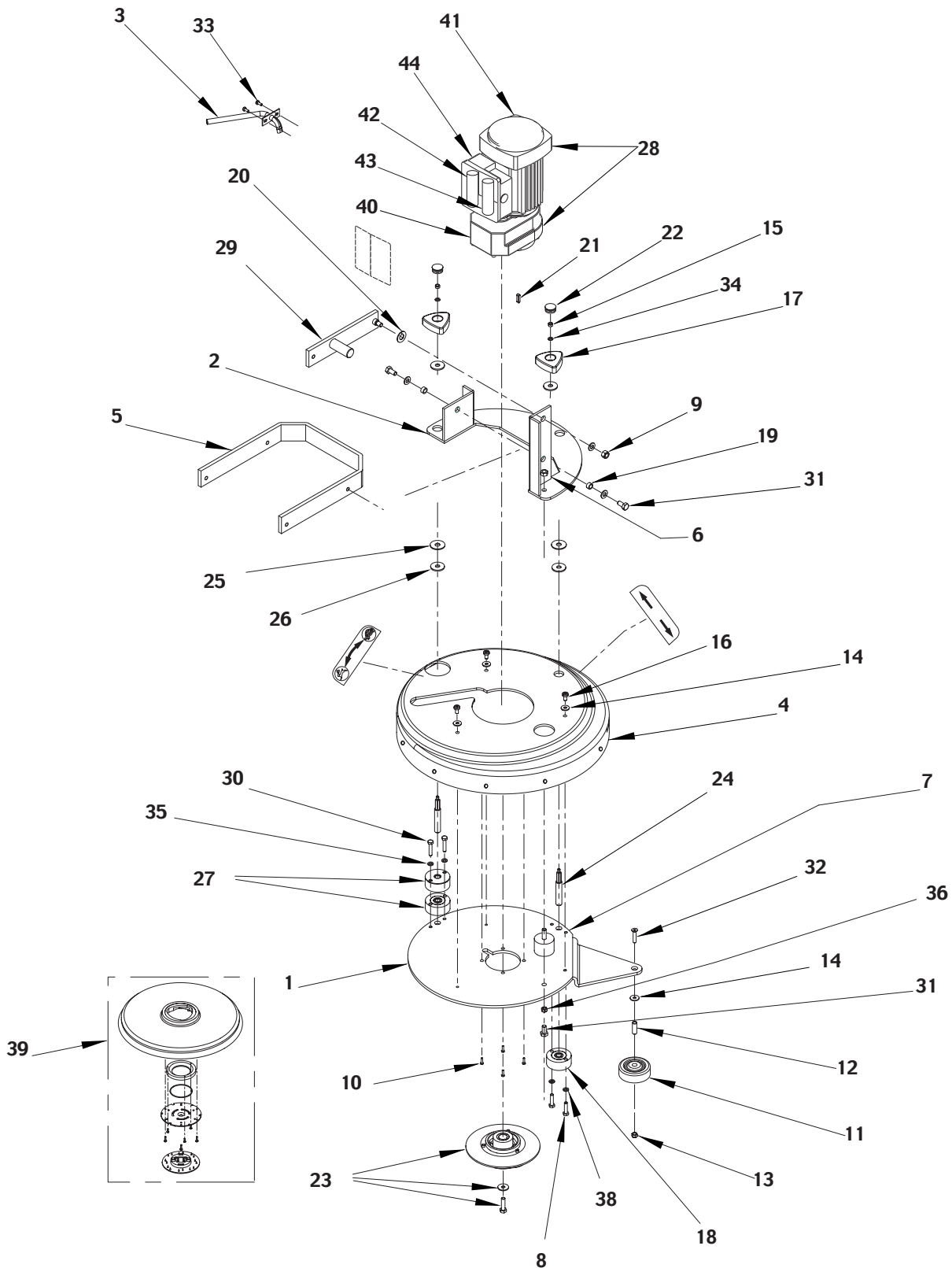

2005-01	BRUSH SYSTEM			
2004-06	MICROMAX™ 17E			13

Item no.	Ref. No.	Qty	Description
1#	L08812889	1	Brush holder plate
2#	L08812892	1	Brush support plate
3#	L08812921	1	Hose copper
4	909 5711 000	1	Brush guard
5#	L08812924	1	Brush lifting frame
6	xxxxxxx	1	Nut hex M8 (Brush System Hardware Kit)
7	xxxxxxx	1	Vibration damping M8 (Brush System Hardware Kit)
8	xxxxxxx	2	Screw hex hd M6x25 (Brush System Hardware Kit)
9	xxxxxxx	1	Nut hex selflocking M8 low (Brush System Hardware Kit)
10	xxx xxxx xxx	4	Screw hex hd M6x16 SS (Brush System Hardware Kit)
11	56363855	1	Bumper roller
12#	L08602461	1	Bushing ø 6.8x9x26
13	xxxxxxx	1	Nut hex selflocking low M6 (Brush System Hardware Kit)
14	xxxxxxx	4	Washer flat 6x18 (Brush System Hardware Kit)
15	xxx xxxx xxx	2	Nut hex selflocking M5 (Brush System Hardware Kit)
16	xxxxxxx	3	Screw 6x16 (Brush System Hardware Kit)
17	56325616	2	Knob
18	56325622	2	Buffer (Brush plate fixing kit)
19	56325598	2	Bushing
20	xxxxxxx	1	Washer ø 12x24x1.5 (Brush System Hardware Kit)
21	145 9774 000	1	Key 5x5x20
22	56325614	2	Cap for knob
23#	L08812589	1	Polygonal holder kit
24#	L08812706	2	Brush plate fixing pin
25#	L08812718	2	Washer rubber 10x30x2
26	xxxxxxx	4	Washer flat 9x28 (Brush System Hardware Kit)
27#	L08812780	1	Brush plate fixing kit (18)
28	909 5472 000	1	Reduction gearmotor 115V
29	909 5608 000	1	Brush lifting lever
30	xxxxxxx	2	Screw hex hd M6x30 (Brush System Hardware Kit)
31	xxxxxxx	3	Screw hex hd M8x16 (Brush System Hardware Kit)
32	xxx xxxx xxx	1	Screw M6x40 (Brush System Hardware Kit)
33	xxx xxxx xxx	2	Screw hex hd M4x8 (Brush System Hardware Kit)
34	xxxxxxx	2	Washer flat 5x10 (Brush System Hardware Kit)
35	xxx xxxx xxx	2	Washer flat 6x12,5 (Brush System Hardware Kit)
36	xxxxxxx	3	Washer flat 8x17 (Brush System Hardware Kit)
[37]	909 5170 000	5	Rivet ø 8
38	xxx xxxx xxx	2	Washer split 6 (Brush System Hardware Kit)
39#	L08837017	1	Pad holder kit complete
40	909 5480 000	1	Reduction gear
41	909 5482 000	1	Electric motor 1100W 115V
42	909 5481 000	1	Capacitor 450V 40uF
43	909 5106 000	1	Capacitor 400V 65uF
44	909 5107 000	1	Box
[45]#	L08603960	1	Brush System Hardware Kit (6,7,8,9,10,13,14,15,16,20,26,30,31,32,33,34,35,36,38)
[46]	909 5172 000	1	Splash guard

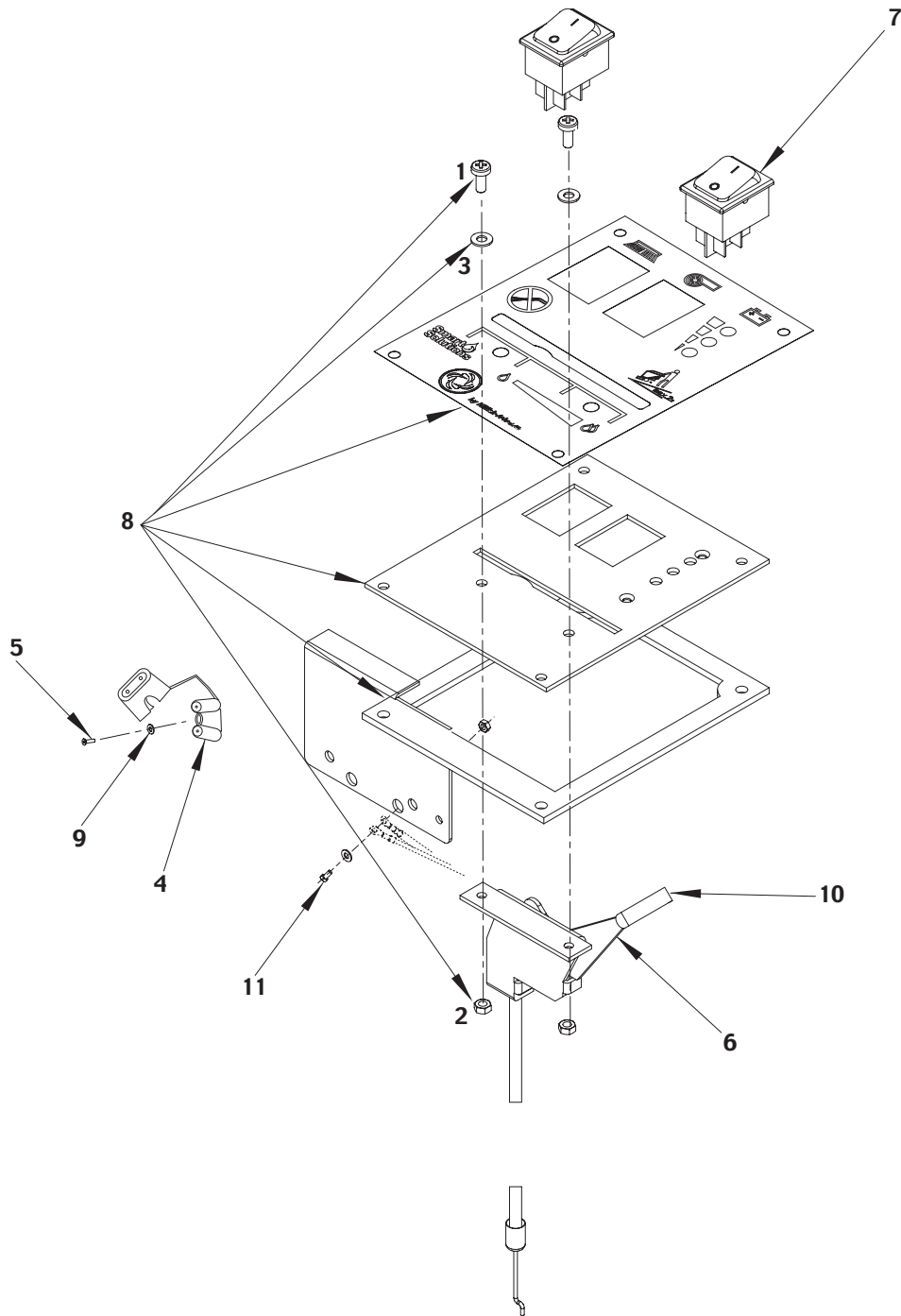

2005-01	CONTROL PANEL SYSTEM		
2004-06	MICROMAX™ 17E		15

Item no.	Ref. No.	Qty	Description
1	xxxxxxx	2	Screw M4x10
2	xxxxxxx	3	Nut hex M4
3	xxxxxxx	2	Washer flat 4x9
4#	L08338600	1	Cap bracket
5	145 9650 000	1	Screw 4x12
6#	L08812938	1	Cable
7	909 5584 000	2	Switch
8	909 5880 000	1	Kit control panel w/decal with smart solution
9	145 9296 000	2	Washer
10#	L08603790	1	Knob
11#	L08191900	1	Hearth connection screw hex hd M4x12
[12]#	L08603961	1	Control panel Hardware kit (1,2,3)

2005-01	WIRING SYSTEM		
2004-06	MICROMAX™ 17E		17

Item no.	Ref. No.	Qty	Description
1#	L08812958	1	Brush cable
2#	L08812957	1	Vacuum cable
3#	L08812956	1	Solenoid cable
4#	L08812955	1	Ground cable
5#	L08812916	2	Cable bridge
6#	L08239900	3	Clamp grey
7#	L08603041	3	Screw M5x10
8	145 1241 000	6	Clamp 2.9x130
9#	L08603885	1	Connector type DIN 46340
10	145 3733 000	1	Connector
11	909 5790 000	1	Power supply cable
[12]	909 5791 000	1	Cable extention 20 m
[13]	909 5792 000	1	Cable sheath

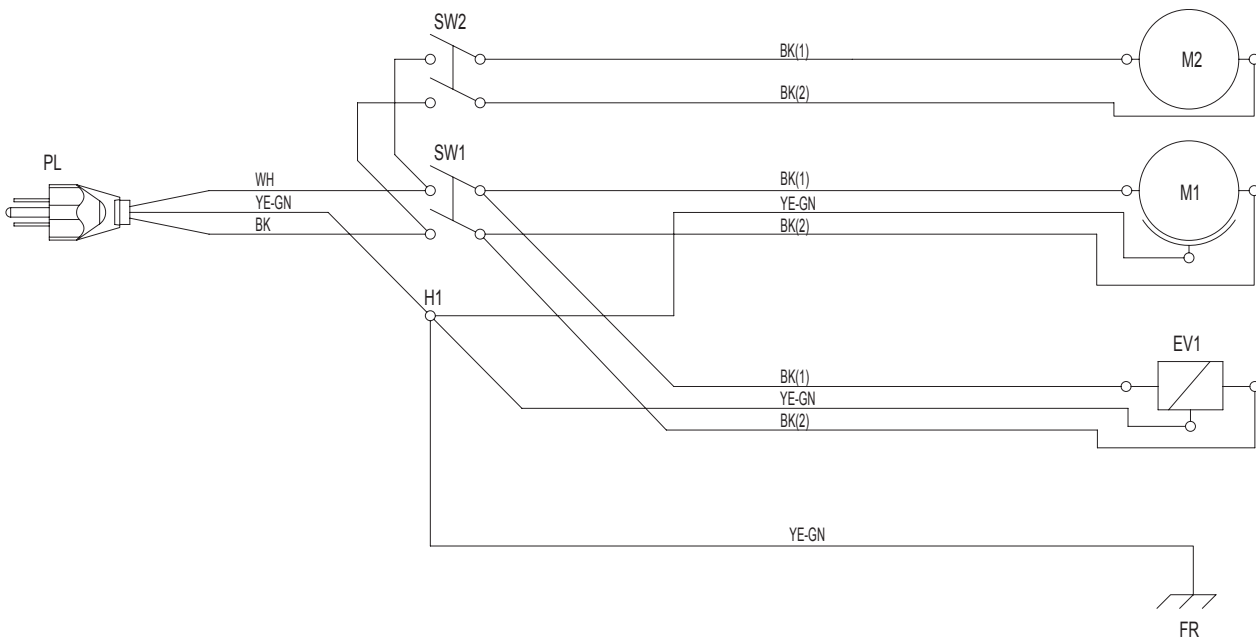

LEGENDA	
EV1	SOLENOID VALVE 110V 08812959
FR	CHASSIS 909 5152 000
H1	HEARTH CONNECTION SCREW 08191900
M1	BRUSH MOTOR - 909 5472 0000
M2	VACUUM MOTOR - 08812848
PL	PLUG - included in 909 5790 000
SW1	BRUSH SWITCH - 909 5584 000
SW2	VACUUM SWITCH - 909 5584 000

COLORS CODES		
BK	BLACK	nero
BU	BLUE	azzurro
BN	BROWN	marrone
GN	GREEN	verde
GY	GREY	grigio
OG	ORANGE	arancio
PK	PINK	rosa
RD	RED	rosso
VT	VIOLET	viola
WH	WHITE	bianco
YE	YELLOW	giallo

2005-01	RECOMMENDED SPARE PARTS		
2004-06	MICROMAX™ 17E		19

**Item
no.**

Ref. No.

Qty

Description

Solution System

909 5780 000	1	Solenoid valve kit complete
909 5151 000	1	Water filter
56325648	2	Rubber holder
L08812959	1	Solenoid valve 110V
909 5787 000	1	Valve with pipe holder kit

Tank System

146 0741 000	1	Tank cover gasket
L08812869	1	Drain hose
L08812873	1	Drain hose complete
L08812848	1	Kit vacuum motor w/ connector
L08603970	1	Squeegee lifting lever kit
909 5420 000	1	Solution hose
909 5583 000	1	Flexible suction hose
L08603860	1	Handle adjuster kit
909 5099 000	1	Ratchet handle adjuster kit

Brush System

909 5472 000	1	Reduction gear motor 115V
56325622	1	Buffer for brush plate
56325616	1	Knob for brush plate
L08812706	1	Brush plate fixing pin
L08603960	1	Brush System Hardware Kit

Chassis System

L08603861	1	Kit castor wheel rear
145 8478 000	1	Pedal cover
L08603862	1	Kit tank support right
L08603863	1	Kit tank support left

Squeegee Assembly

L08603878	1	Kit squeegee complete
56325685	1	Squeegee blade rear
56393285	1	Squeegee blade front
56325684	1	Adjustment screw kit
L08603879	1	Kit squeegee wheel

Control Panel System

909 5584 000	1	Switch
--------------	---	--------

Wiring system

909 5790 000	1	Power supply cable
L08812955	1	Ground cable
145 3733 000	1	Connector



**Nilfisk
Advance**

setting standards

Nilfisk-Advance, Inc.
14600 21st Avenue North
Plymouth, MN, 55447-3408
www.nilfisk-advance.com
Phone: 800-989-2235
Fax: 800-989-6566

©2005 Nilfisk-Advance, Inc.,
Plymouth, MN 55447-3408
Printed in Italy