

PARTS LIST

CHARGER 2717 DB

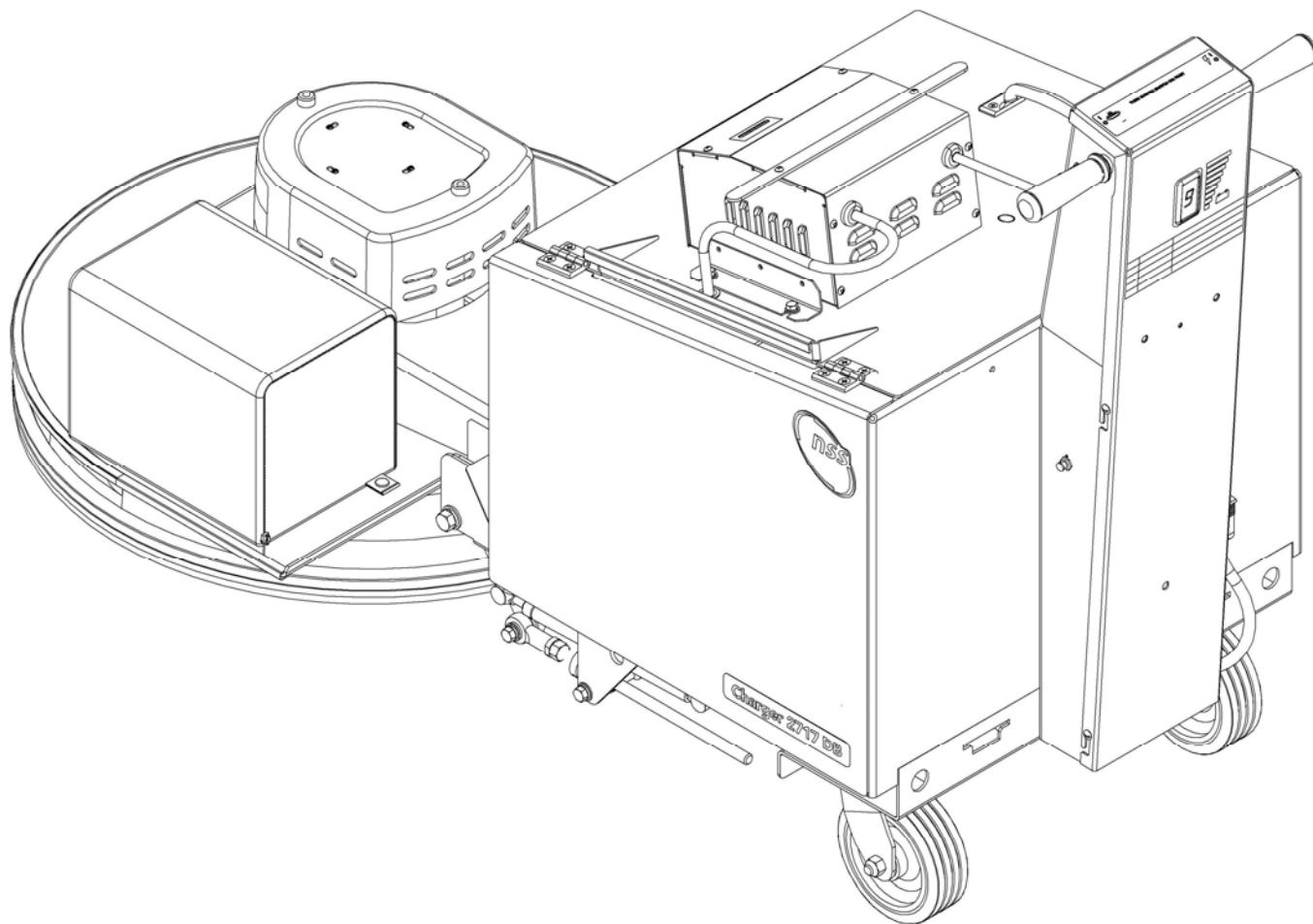

SAVE THESE INSTRUCTIONS



CHASSIS AND DRIVE ASSEMBLY

<u>ITEM</u>	<u>PART NO.</u>	<u>DESCRIPTION</u>	<u>QTY</u>
101	6498051	AXLE / PIVOT MOUNT	2
102	9122260	3/8-16 X 1 HEX BOLT - PACK OF 2	4
103	9122100	3/8 SPLIT LOCK WASHER - PACK OF 10	4
104	9122180	13/32 X 13/16 X .051 THICK WASHER - PACK OF 10	4
105	2691181	PIVOT SPACER, STABILIZER BAR	4
106	6495891	PIVOT	2
107	9122180	13/32 X 13/16 X .051 THICK WASHER - PACK OF 10	4
108	9122100	3/8 SPLIT LOCK WASHER - PACK OF 10	4
109	9122260	3/8-16 X 1 HEX BOLT - PACK OF 5	4
110	2694069	#40 ROLLER CHAIN 57 LINKS WITH MASTER	1
	2694081	#40 ROLLER CHAIN 57 LINKS NO MASTER	1
	2795211	LINK - MASTER #40 CHAIN NICKEL PLATED	1
	2795221	HALF LINK (OFFSET LINK)	1
111	2692271	DRIVE WHEEL SPACER 1" 1.0 X .6875	1
112	9121310	1/4 SQUARE X 7/8 LONG KEY - STEEL - PACK OF 2	1
113	2694051	DRIVEN SPROCKET #34 TEETH	1
114	9121380	5/16-18 X 3/8 SET SCREW - KNURL POINT - PACK OF 2	1
115	9121317	1/4 SQUARE X 3 3/4 LONG KEY - PACK OF 2	1
116	6496521	10 INCH DRIVE WHEEL (GREY RUBBER)	1
117	9121380	5/16-18 X 3/8 SET SCREW - KNURL POINT - PACK OF 2	2
118	6590521	1 I.D. X 1.5 O.D. X .13 THICK FLAT WASHER - 10 GA	8
119	9122180	13/32 X 13/16 X .051 THICK WASHER - PACK OF 10	4
120	9122100	3/8 SPLIT LOCK WASHER - PACK OF 10	4
121	9122300	3/8-16 X 1 1/4 HEX BOLT - PACK OF 2	4
122	3392571	AXLE, DRIVE WHEEL	1
123	3393121	PILLOW BLOCK BEARING STRAIGHT ZERK	2
124	2790101	DRIVE MOTOR 36 VOLT	1
125	9120850	1/4-20 X 5/16 SET SCREW - KNURL POINT - PACK OF 2	2
126	9121400	3/8 I.D. 7/8 O.D. WROUGHT WASHER 5/16 - PACK OF 10	1
127	9121520	5/16 SPLIT LOCK WASHER - PACK OF 10	1
128	9121640	5/16-18 X 3/4 HEX BOLT - PACK OF 5	1
129	9122260	3/8-16 X 1 HEX BOLT - PACK OF 5	3
130	9122100	3/8 SPLIT LOCK WASHER - PACK OF 10	3
131	9122180	13/32 X 13/16 X .051 THICK WASHER - PACK OF 10	3
132	9120930	9/32 I.D. X 5/8 O.D. FLAT WASHER (1/4) - PACK OF 10	4
133	9120880	1/4 SPLIT LOCK WASHER - PACK OF 10	4
134	9121250	1/4-20 X 3/4 HEX BOLT - PACK OF 10	4
135	6497291	DRIVE MOTOR MOUNT	1
136	9121420	5/16-18 HEX NUT - PACK OF 10	2
137	2792681	1/4" X 1/4" X 1" MOTOR KEY	1
138	2695011	DRIVE SPROCKET, MOTOR WITH SET SCREW	1
139	2690581	1/4 SPADE MALE TERMINAL 10-12 AWG, YELLOW	2
140	9122260	3/8-16 X 1 HEX BOLT - PACK OF 5	4
141	9122100	3/8 SPLIT LOCK WASHER - PACK OF 10	4
142	9122180	13/32 X 13/16 X .051 THICK WASHER - PACK OF 10	4
143	6496541	BALL STUD - GAS SPRING MOUNT	2
144	9121410	5/16 EXTERNAL STAR LOCK WASHER - PACK OF 10	2
145	6497201	GAS SPRING MOUNT	2
146	9122260	3/8-16 X 1 HEX BOLT - PACK OF 5	8
147	9122100	3/8 SPLIT LOCK WASHER - PACK OF 10	8
148	9122180	13/32 X 13/16 X .051 THICK WASHER - PACK OF 10	8
149	3394991	6" X 2" YELLOW CASTER ASSEMBLY	2
149A	3395001	YELLOW CASTER WHEEL - ONLY	2
150	6491860	ROUND BEAD CHAIN - CUT TO 8"	.7'
151	9120330	#10 EXTERNAL STAR LOCK WASHER - PACK OF 10	1
152	9120380	#10-24 X 3/8 ROUND HEAD PHILLIPS MACHINE SCREW - PACK OF 10	1
153	6491871	END COUPLING ROUND BEAD CHAIN	1
154	6497061	CHASSIS / BODY	1

CHASSIS AND DRIVE ASSEMBLY

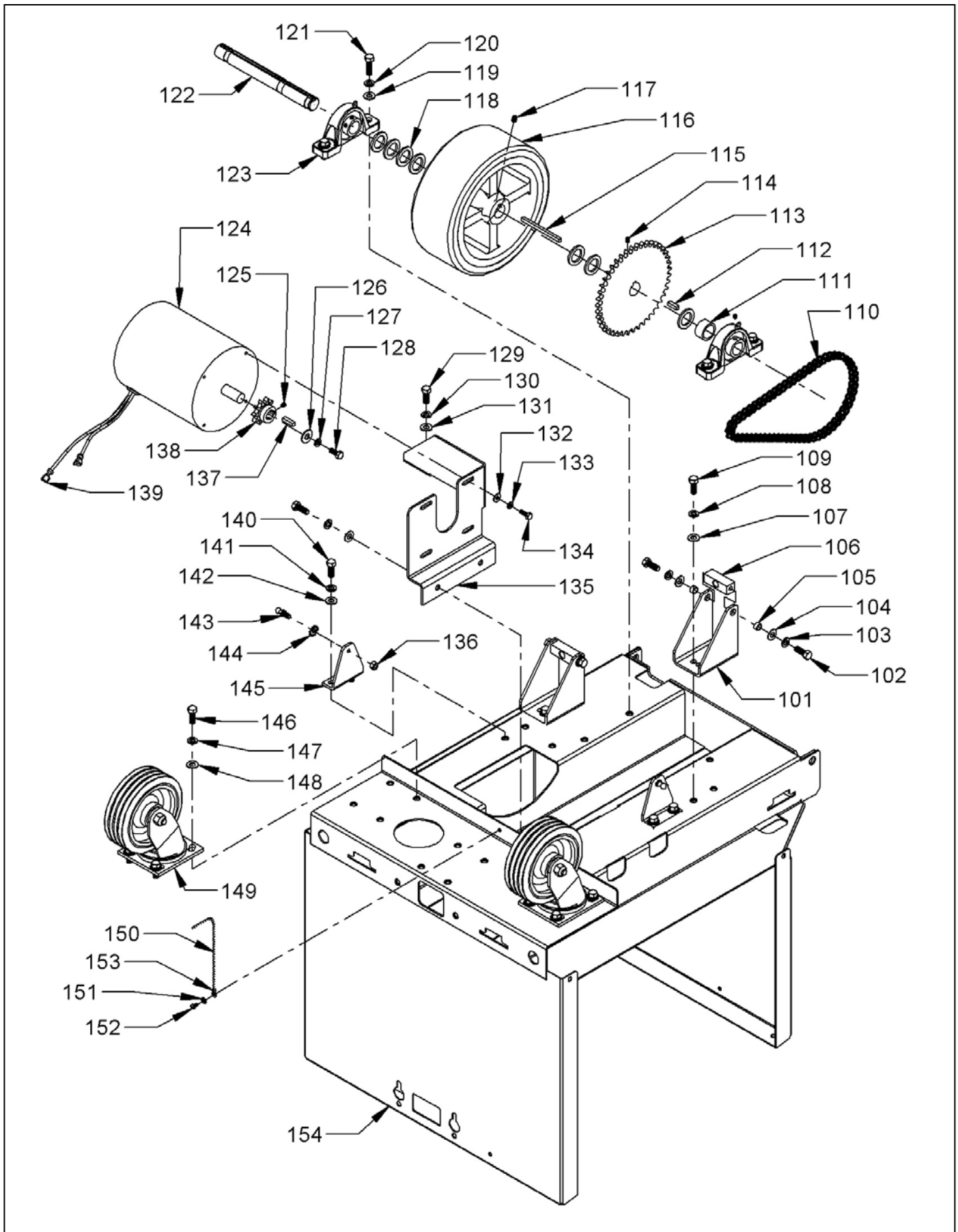

HEAD ASSEMBLY

ITEM	PART NO.	DESCRIPTION	QTY
201	5990731	SPRING CLIP PAD HOLDER SET - INCLUDES:	1
201A	9120205	#8 X 1/2 PAN HEAD PHILLIPS SHEET METAL SCREW - PACK OF 3	3
203	9121490	5/16-24 X 7/8 HEX BOLT - PACK OF 2	1
204	9121520	5/16 SPLIT LOCK WASHER - PACK OF 10	1
205	9120827	3/16 SQUARE X 1" LONG KEY - STEEL - PACK OF 2	1
206	6499789	DRIVER, 27" FLEX-LOC PAD	1
207	9120980	1/4-20 X 1 SOCKET HEAD CAP SCREW - PACK OF 5	3
208	9120880	1/4 SPLIT LOCK WASHER - PACK OF 10	3
209	9120950	1/4 X 1 1/4 FENDER WASHER - PACK OF 10	3
210	6496519	FLEXIWALL SHIELD 27 ASSEMBLY - INCLUDES:	1
210A	6592531	BUMPER / BRUSH 27"	1
210B	6592552	BUMPER STRAP 27	1
210C	9120350	#10-24 HEX NUT WITH NY-LOCK INSERT - PACK OF 10	1
210D	9120450	#10-24 X 1 ROUND HEAD PHILLIPS MACHINE SCREW - PACK OF 10	1
211	9997590	METAL CORE QUICKEDGE TRIM - CUT TO 67"	5.6'
212	6499001	MOTOR, PAD, 29 VOLT, P66LR015	1
213	7692421	TERMINAL BOOT (RED)	1
214	9121410	5/16 EXTERNAL STAR LOCK WASHER - PACK OF 10	2
215	6496621	STEEL SKIRT - 27"	1
216	6496881	STUD WITH #10-32 X 3/8, FILTER BAG	1
217	9120660	#10-32 X HEX NUT WITH NY-LOCK INSERT - PACK OF 10	1
218	9121985	13/32 I.D. X 1 O.D. X .12 THICK FLAT WASHER (11 GA) - PACK OF 1	1
219	9123105	3/4 I.D. X 1-1/4 O.D. X .071 THICK FLAT WASHER - PACK OF 5	1

HEAD ASSEMBLY

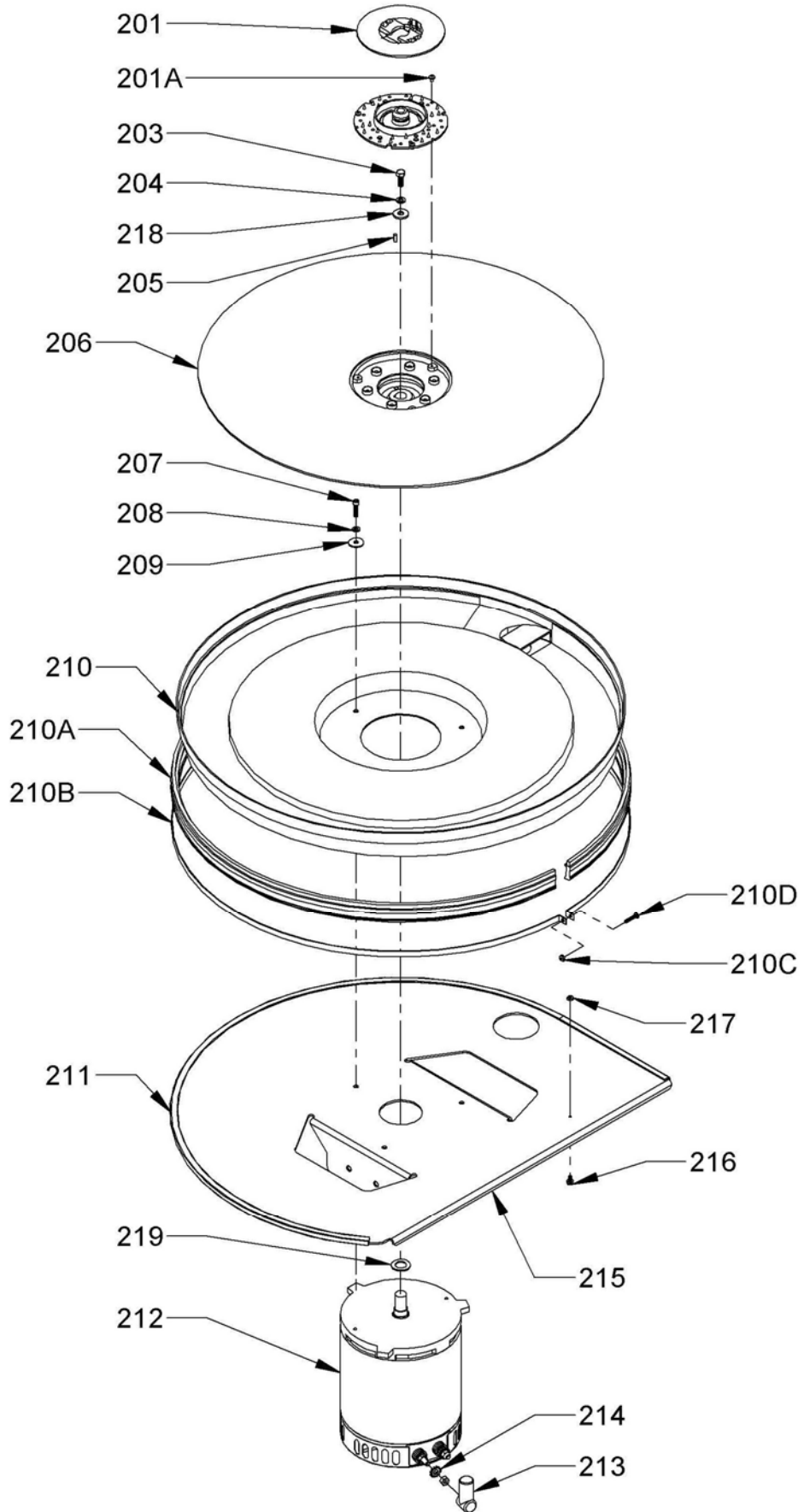

HEAD ARM ASSEMBLY

ITEM	PART NO.	DESCRIPTION	QTY
301	9120600	#10-24 X 1/2 PAN HEAD PHILLIPS THREAD CUTTING SCREW - PACK OF 10	4
302	9120370	7/32 I.D. X 1/2 O.D. X .032/.065 THICK FLAT WASHER (#10) - PACK OF 10	2
303	9120205	#8 X 1/2 PAN HEAD PHILLIPS SHEET METAL SCREW - PACK OF 3	2
304	6793371	RUBBER FOOT	2
306	6496641	MOTOR COVER	1
307	9122260	3/8-16 X 1 HEX BOLT - PACK OF 2	1
308	9122100	3/8 SPLIT LOCK WASHER - PACK OF 10	1
309	6497551	ARM - 27 BRUSH ASSEMBLY	1
310	6496651	GRIP BASE	1
311	3392901	HANDLE GRIP	1
312	9122020	3/8 X 3/8 SOCKET HEAD SHOULDER BOLT - PACK OF 1	4
313	9120530	#10-24 X 7/8 TRUSS HEAD PHILLIPS MACHINE SCREW - PACK OF 5	2
314	2790751	BUSHING SPACER	2
315	9122450	17/32 I.D. X 1 1/16 O.D. X .074/.121 THICK FLAT WASHER (1/2) - PACK OF 5	2
316	9122420	1/2 SPLIT LOCK WASHER - PACK OF 5	2
317	9122550	1/2-13 X 1 1/2 HEX BOLT - PACK OF 1	2
318	6496711	BAG, FILTER MEDIA	1
319	6496671	COMPRESSION SPRING 1.75 X .935 O.D.	2
320	9122340	3/8-16 X 2 HEX BOLT - PACK OF 2	2
321	9122100	3/8 SPLIT LOCK WASHER - PACK OF 10	2
322	9122180	13/32 I.D. X 13/16 O.D. X .051/.080 THICK FLAT WASHER (3/8) - PACK OF 10	2
323	6497801	GUIDE, SPRING	2
324	3393891	COLLAR, SHAFT 1/2"	2
325	9122670	1/2-20 HEX JAM NUT - PACK OF 5	2
326	2391941	BALL JOINT	2
327	6498061	SPACER 1/2 O.D.X 3/8 I.D. X 3/4 LONG	2
328	9121985	13/32 I.D. X 1 O.D. X .12 THICK FLAT WASHER (11 GA) - PACK OF 1	2
329	9122140	3/8-16 HEX NUT WITH NY=LOCK INSERT - PACK OF 5	2
330	9121450	5/16-18 HEX NUT WITH NY-LOCK INSERT - PACK OF 5	1
331	2395761	CLAMP, TUBE	1
332	9121410	5/16 EXTERNAL STAR LOCK WASHER - PACK OF 10	2
333	6496541	BALL STUD - GAS SPRING MOUNT	2
334	6496531	GAS SPRING (GGS 23-120 I) - INCLUDES:	2
	6496771	SPRING CLIP	2
335	9120350	#10-24 HEX NUT WITH NY-LOCK INSERT - PACK OF 10	2
336	6496781	TILT SWITCH	1
337	4991371	FULLY INSULATED MALE TERMINAL 22-18 AWG	2
338	9121600	5/16-18 X 5/8 HEX NUT - PACK OF 5	1

HEAD ARM ASSEMBLY

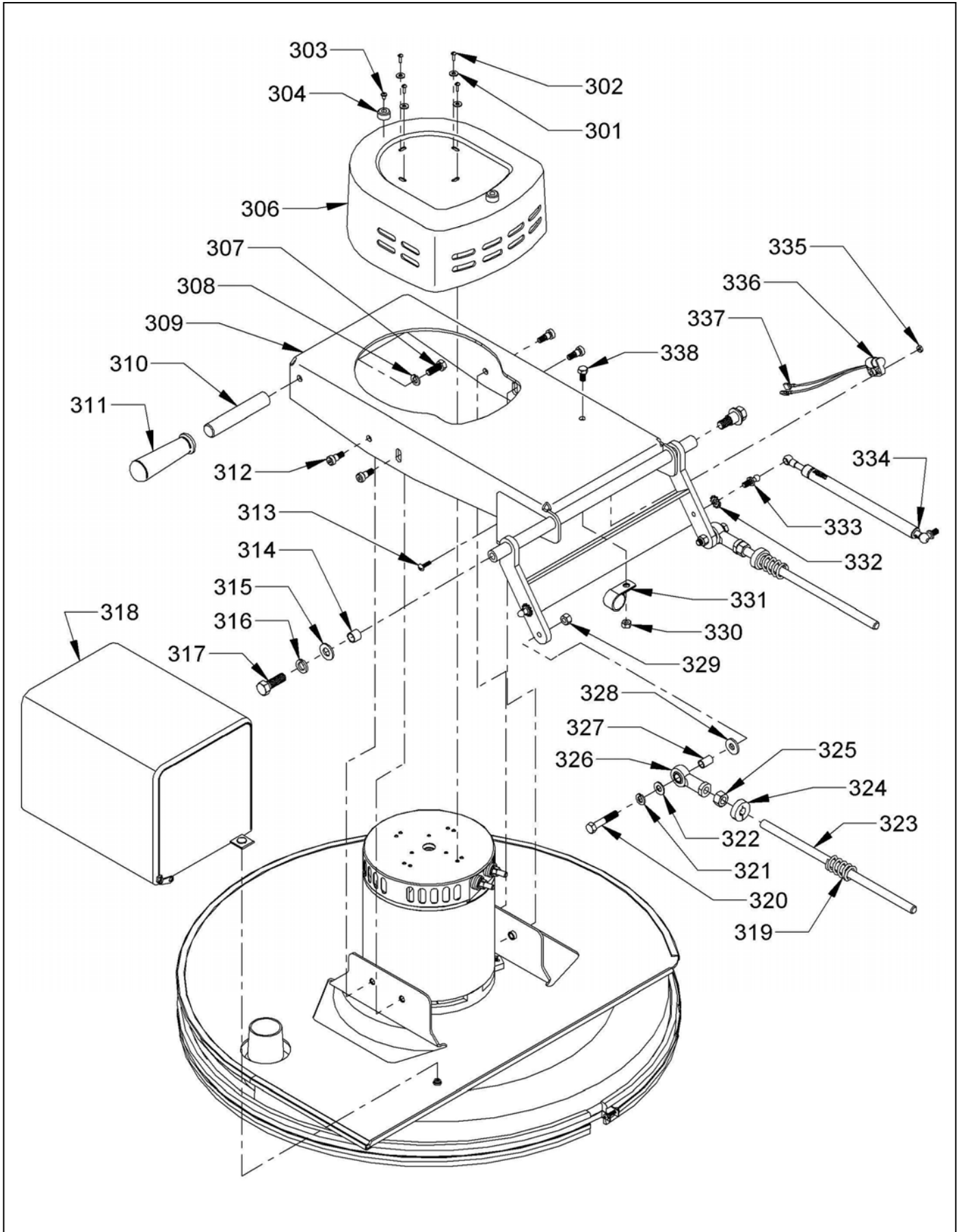

CONTROL PANEL ASSEMBLY

<u>ITEM</u>	<u>PART NO.</u>	<u>DESCRIPTION</u>	<u>QTY</u>
401	3392901	HANDLE GRIP	2
402	2691871	HANDLE GRIP BASE	2
403	3393891	COLLAR, SHAFT 1/2"	2
404	2391941	BALL JOINT	2
405	2694131	POTENTIOMETER	1
406	6496991	POTENTIOMETER BRACKET	1
407	9120225	#8-32 X 1/4 SET SCREW - KNURL POINT - STEEL - PACK OF 10	2
408	2691941	DRIVEN GEAR, POTENTIOMETER	1
409	9122420	1/2 SPLIT LOCK WASHER - PACK OF 5	2
410	9122700	1/2-20 X 1 HEX BOLT - PACK OF 2	2
411	9120510	#10-24 X 1/2 TRUSS HEAD PHILLIPS MACHINE SCREW - PACK OF 10	2
412	9120330	#10 EXTERNAL STAR LOCK WASHER - PACK OF 10	2
413	9120370	7/32 I.D. X 1/2 O.D. X .032/.065 THICK FLAT WASHER (#10) - PACK OF 10	2
414	9120430	#10-24 X 3/4 ROUND HEAD PHILLIPS MACHINE SCREW - PACK OF 10	4
415	9120370	7/32 I.D. X 1/2 O.D. X .032/.065 THICK FLAT WASHER (#10) - PACK OF 10	4
416	6496811	WIRE ASSEMBLY, ANDERSON - MACHINE - INCLUDES:	1
	6491841	175 AMP ANDERSON WITH CONTACTS GRAY 36 VOLT	1
417	9120900	1/4-20 HEX NUT WITH NY-LOCK INSERT - PACK OF 10	2
418	9120910	1/4-20 HEX NUT WITH STAR LOCK WASHER - PACK OF 10	2
419	6496441	CIRCUIT BREAKER - 125 AMP	1
420	9120027	5/32 I.D. X 3/8 O.D. 5/64 THICK FLAT WASHER (#6 SAE) – PACK OF 10	2
421	9120130	#6 EXTERNAL STAR LOCK WASHER - PACK OF 10	2
422	9120070	#6-32 X 3/8 ROUND HEAD PHILLIPS MACHINE SCREW - PACK OF 10	2
423	9120510	#10-24 X 1/2 TRUSS HEAD PHILLIPS MACHINE SCREW - PACK OF 10	5
424	6496471	CONTROL FRAME	1
425	6497411	CONTROL FRAME COVER	1
427	6496971	BATTERY METER WITH HARNESS - INCLUDES:	1
	6496981	BATTERY METER DISPLAY	1
	6496961	WIRE HARNESS, BATTERY METER - 10 PIN	1
428	6498401	BATTERY METER/CODES DECAL	1
429	6498341	MASTER SWITCH LABEL	1
430	6497039	KEY SWITCH KIT (OPTIONAL) - INCLUDES:	1
	7692511	KEY SWITCH & KEY	1
	7692521	REPLACEMENT KEYS – SET OF TWO	1
	6497021	WIRE ASSEMBLY, KEY SWITCH	1
431	2397361	HOUR METER	1
432	6496451	FAST-ACTING FUSE 2 AMP	1
433	4990321	FUSE HOLDER WITH NUT & WASHER	1
434	3394721	FUSE DECAL	1
435	6498351	CONTROLLER, 2717DB, UL, 0144 – 0001	1
	9120970	1/4 EXTERNAL STAR LOCK WASHER - PACK OF 10	5
	9120985	1/4-28 X 3/8 PAN HEAD PHILLIPS MACHINE SCREW	5
436	6497561	DECAL, WIRING DIAGRAM	1
437	9120350	#10-24 HEX NUT WITH NY-LOCK INSERT - PACK OF 10	4
438	9120350	#10-24 HEX NUT WITH NY-LOCK INSERT - PACK OF 10	2
439	9120370	7/32 I.D. X 1/2 O.D. X .032/.065 THICK FLAT WASHER (#10) - PACK OF 10	2
440	6496481	SOLENOID, 36 VOLT	1
441	7692421	TERMINAL BOOT (RED)	1
442	9121210	1/4-20 X 5/8 HEX BOLT - PACK OF 10	1
443	9120970	1/4 EXTERNAL STAR LOCK WASHER - PACK OF 10	1
444	4490561	INSULATED STANDOFF	1
445	9120880	1/4 SPLIT LOCK WASHER - PACK OF 10	1
446	9121170	1/4-20 X 1/2 HEX BOLT - PACK OF 10	1
447	9121060	1/4-20 X 1 1/4 HEX BOLT - PACK OF 5	2
448	9122465	.516 I.D. X .813 O.D. X .027/.030 THICK FLAT WASHER - PACK OF 2	2
449	9121975	1/2 INTERNAL STAR LOCK WASHER – PACK OF 5	2
450	0798821	5/8" HEX NUT (LARGE NUT)	2
451	4491101	TOGGLE SWITCH, MOTOR	2

CONTROL PANEL ASSEMBLY

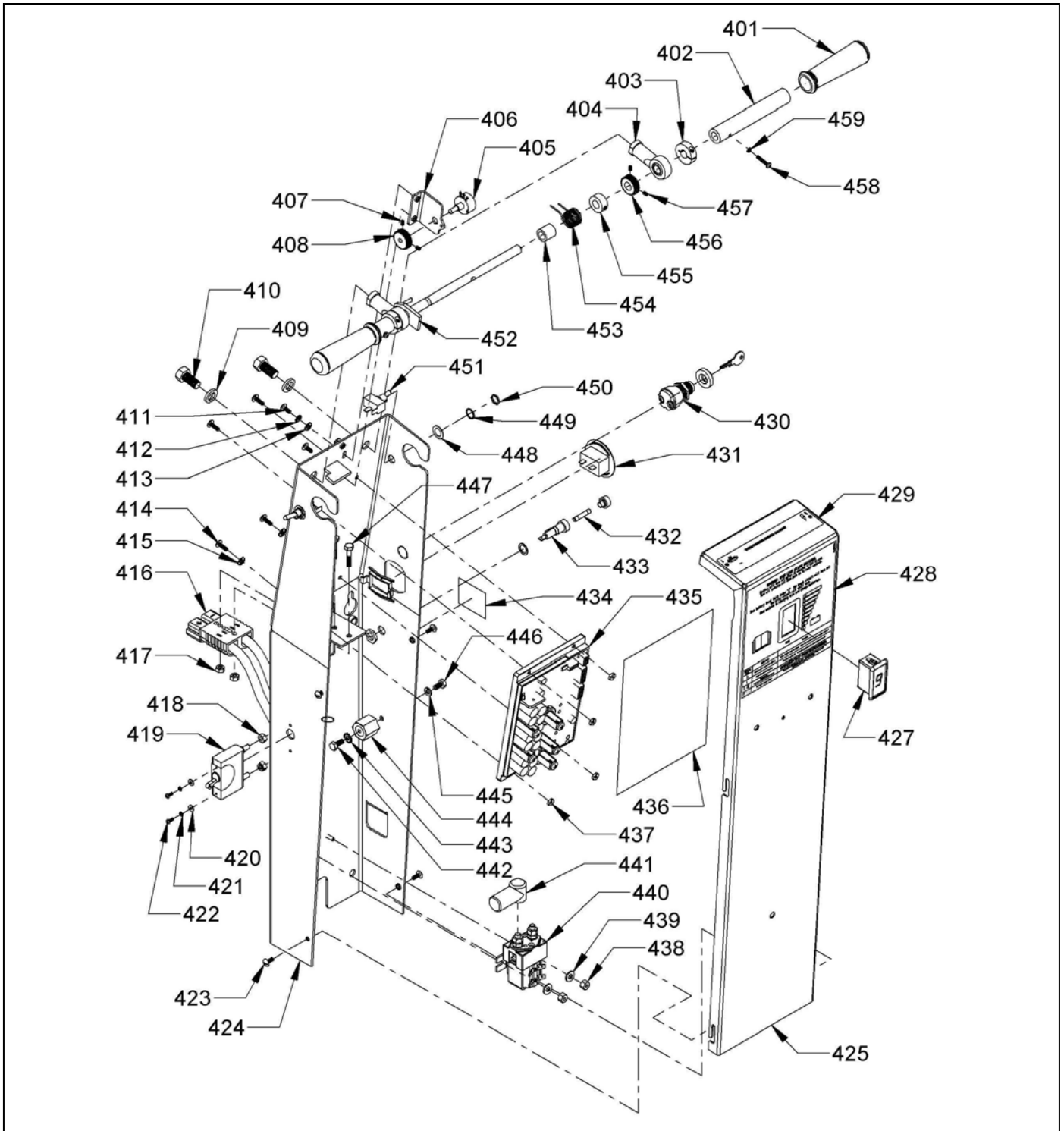

<u>ITEM</u>	<u>PART NO.</u>	<u>DESCRIPTION</u>	<u>QTY</u>
452	6496191	HANDLE BAR 2716	1
453	6496081	BEARING PLAIN SLEEVE .5 X .75 X .75 LONG	1
454	6496091	SPRING TORSION .81 I.D. .067 WIRE	1
455	6496171	COLLAR, SHAFT 1/2" SET SCREW	1
456	2691931	DRIVE GEAR, HANDLE BAR	1
457	9120225	#8-32 X 1/4 SET SCREW - KNURL POINT - STEEL - PACK OF 10	2
458	9120270	#8-32 X 7/8 ROUND HEAD PHILLIPS MACHINE SCREW - PACK OF 10	2
459	9120200	#8 SPLIT LOCK WASHER - PACK OF 10	2

LID AND SIDE ASSEMBLY

ITEM	PART NO.	DESCRIPTION	QTY
501	9121270	1/4-20 X 1 HEX BOLT - PACK OF 10	1
502	6498601	36 VOLT ON-BOARD CHARGER 120 VOLT 25 AMP	1
	6498701	36 VOLT ON-BOARD CHARGER 240 VOLT 25 AMP	1
	2695861	CORD WRAP (INCLUDED WITH BATTERY CHARGER)	1
502	6497791	36 VOLT ON-BOARD CHARGER 25 AMP UL	1
	2695861	CORD WRAP (INCLUDED WITH BATTERY CHARGER)	1
502	6495701	120 VOLT ON-BOARD CHARGER CORD	1
502	6495711	240 VOLT ON-BOARD CHARGER CORD	1
503	9121210	1/4-20 X 5/8 HEX BOLT - PACK OF 10	3
504	9120880	1/4 SPLIT LOCK WASHER - PACK OF 10	4
505	9120930	9/32 I.D. X 5/8 O.D. X .051/.080 THICK FLAT WASHER (1/4) - PACK OF 10	3
506	4890451	BUSHING, SNAPIN	1
507	9121035	1/4-20 X 7/8 FLAT HEAD PHILLIPS MACHINE SCREW - PACK OF 10	8
508	6497811	LID HINGE	2
509	6497071	LID, BODY	1
510	9120900	1/4-20 HEX NUT WITH NY-LOCK INSERT - PACK OF 10	8
511	9997590	METAL CORE QUICKEDGE TRIM - CUT TO 12.5"	1
512	4890851	CABLE CLAMP	1
513	9120900	1/4-20 HEX NUT WITH NY-LOCK INSERT - PACK OF 10	4
514	9120900	1/4-20 HEX NUT WITH NY-LOCK INSERT - PACK OF 10	1
515	9120930	9/32 I.D. X 5/8 O.D. X .051/.080 THICK FLAT WASHER (1/4) - PACK OF 10	1
516	9121010	1/4-20 X 3/4 TRUSS HEAD PHILLIPS MACHINE SCREW - PACK OF 5	1
517	6497051	RETAINING STRAP 18", BRUSH HEAD	1
518	6498181	CHARGER 2717 DB LABEL	2
519	6497081	SIDE PANEL	1
520	9120930	9/32 I.D. X 5/8 O.D. X .051/.080 THICK FLAT WASHER (1/4) - PACK OF 10	4
521	9120900	1/4-20 HEX NUT WITH NY-LOCK INSERT - PACK OF 10	4
522	9120520	#10-24 X 5/8 TRUSS HEAD PHILLIPS MACHINE SCREW - PACK OF 10	1
523	9122260	3/8-16 X 1 HEX BOLT - PACK OF 2	4
524	9122100	3/8 SPLIT LOCK WASHER - PACK OF 10	4
525	9122260	3/8-16 X 1 HEX BOLT - PACK OF 2	2
526	9122180	13/32 I.D. X 13/16 O.D. X .051/.080 THICK WROUGHT WASHER (3/8) - PACK OF 10	2
527	9120350	#10-24 HEX NUT WITH NY-LOCK INSERT - PACK OF 10	1
528	9120370	7/32 I.D. X 1/2 O.D. X .032/.065 THICK FLAT WASHER (#10) - PACK OF 10	1
529	4894071	CLAMP, .437 DIAMETER CABLE	1
530	9122000	3/8-16 HEX NUT - PACK OF 10	2
531	9122100	3/8 SPLIT LOCK WASHER - PACK OF 10	2
532	9997560	VELCRO LOOP, PRESSURE SENSITIVE – CUT 2 PCS TO 7" ALONG BACK; CUT 2 PCS TO 6" ALONG SIDE; CUT TO 21" ALONG FRONT	3.9'
533	9122180	13/32 I.D. X 13/16 O.D. X .051/.080 THICK WROUGHT WASHER (3/8) - PACK OF 10	2
534	8791070	VINYL HOSE, 3/8" I.D. X 1/2" O.D. – CUT TO 15" LONG	1.3'
535	3390661	TUBING CONTROL VALVE	1
536	2392481	HOSE CLAMP, 7/32" - 5/8" DIAMETER	1
537	2490601	FITTING, ELL 3/8 BARB X 1/4 NPT	1
538	6496551	BATTERY TRAY	1
539	9997550	VELCRO HOOK, PRESSURE SENSITIVE	.5'
540	6497581	DECAL, BATTERY WARNING – OBC	1
541	3394141	OBC WARNING DECAL	1
542	7692271	LIFT HANDLE	1
543	9120390	#10-24 X 3/8 FLAT HEAD PHILLIPS MACHINE SCREW - PACK OF 10	4
544	3291111	CORD CLAMP	1
545	9120810	#10 X 1/2 PAN HEAD PHILLIPS MACHINE SCREW - PACK OF 10	6
546	2695841	BATTERY CHARGER MOUNTING BRACKET	2
547	6496461	1/4 NPT PLASTIC NUT	1
548	2694921	NSS LOGO LABEL	2

LID AND SIDE ASSEMBLY

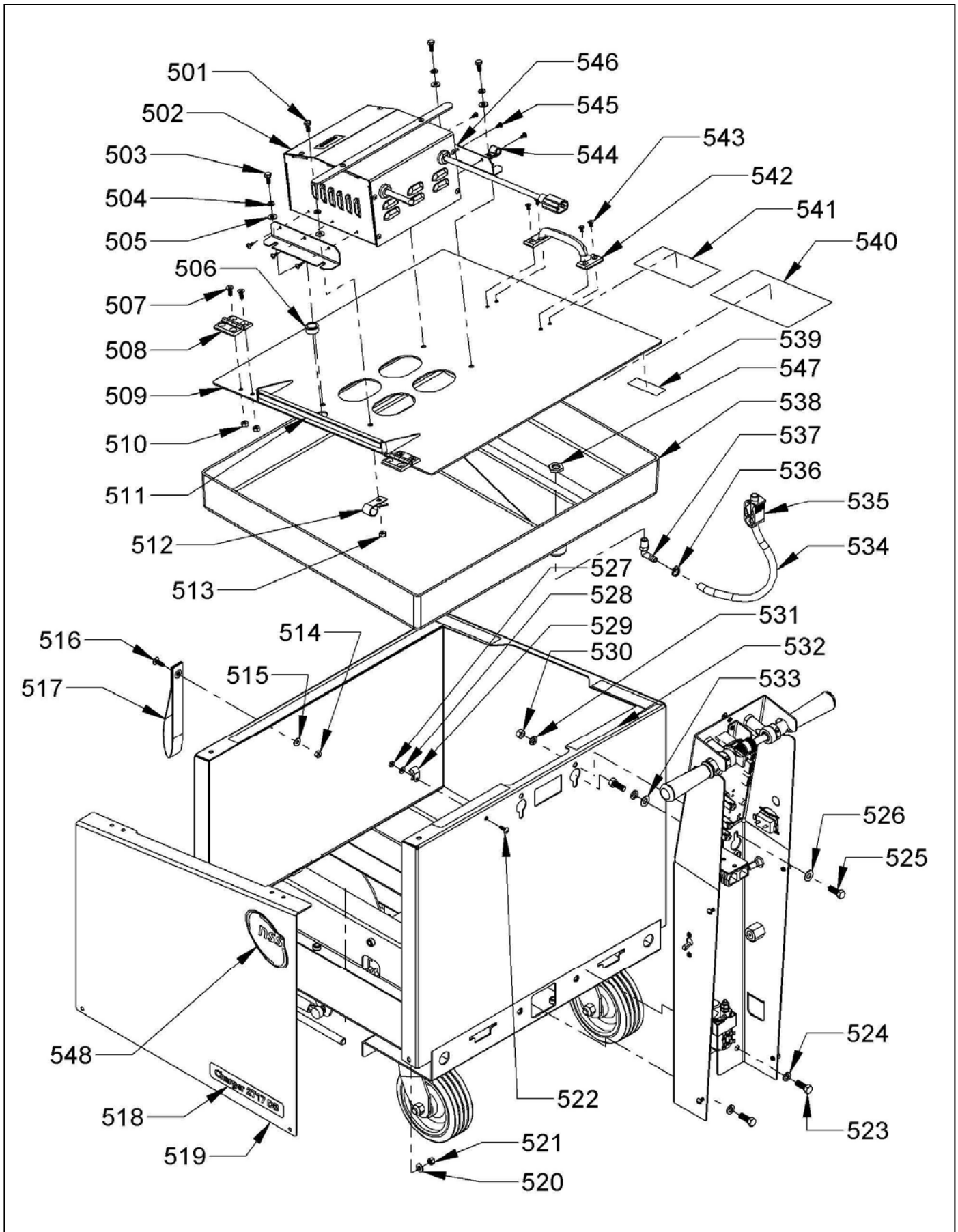

ELECTRICAL COMPONENTS

<u>ITEM</u>	<u>PART NO.</u>	<u>DESCRIPTION</u>	<u>QTY</u>
66	7691661	WIRING ASSEMBLY ANDERSON TO BATTERY	1
80	6496801	WIRE HARNESS, BRUSH MOTOR	1
81	6496811	WIRE ASSEMBLY, ANDERSON – MACHINE	1
82	6496821	WIRE, BREAKER TO STANDOFF	1
83	6496831	WIRE, SOLENOID TO CONTROLLER	1
84	6496841	WIRE, CONROLLER TO STANDOFF	1
86	6496861	WIRE, CONTROLLER TO DRIVE MOTOR	1
87	6496871	WIRE, FUSE HOLDER - MASTER SWITCH	1
89	6496491	WIRE HARNESS, CONTROLLER - 12 PIN	1
94	6496941	WIRE, HOUR METER TO STANDOFF	1
95	6496951	WIRE, WITH 2 AMP FUSE AND HOLDER	1
97	2391981	BATTERY JUMPER 3/8" RING	5
--	2690581	1/4 SPADE MALE TERMINAL 10-12 AWG, YELLOW	2
--	2694131	POTENTIOMETER	1
--	2790101	DRIVE MOTOR 36 VOLT	1
--	4490561	INSULATED STANDOFF	1
--	6496481	SOLENOID, 36 VOLT	1
--	4491101	TOGGLE SWITCH, MOTOR	2
--	4990321	FUSE HOLDER WITH NUT & WASHER	1
--	4991371	FULLY INSULATED MALE TERMINAL 22-18 AWG	2
--	5392331	SWITCH (SULKY)	1
--	6496441	CIRCUIT BREAKER - 125 AMP	1
--	6498601	36 VOLT ON-BOARD CHARGER 120 VOLT 25 AMP	1
--	6498701	36 VOLT ON-BOARD CHARGER 240 VOLT 25 AMP	1
--	6495701	120 VOLT ON-BOARD CHARGER CORD	1
--	6495711	240 VOLT ON-BOARD CHARGER CORD	1
--	6496451	FAST-ACTING FUSE 2 AMP	2
--	6499001	MOTOR, PAD, 29 VOLT, P66LR015	1
--	6498351	CONTROLLER, BURNISHER +DRIVE, 588TS	1
--	6496781	TILT SWITCH	1
--	6496971	BATTERY METER WITH HARNESS	1
--	6496981	BATTERY METER DISPLAY	1
--	6496961	WIRE HARNESS, BATTERY METER - 10 PIN	1
--	6497039	KEY SWITCH KIT (OPTIONAL) - INCLUDES:	1
--	7692511	KEY SWITCH & KEY	1
--	7692521	REPLACEMENT KEY FOR SWITCH 7692511	1
02	6497021	WIRE ASSEMBLY, KEY SWITCH	1

WIRING DIAGRAM

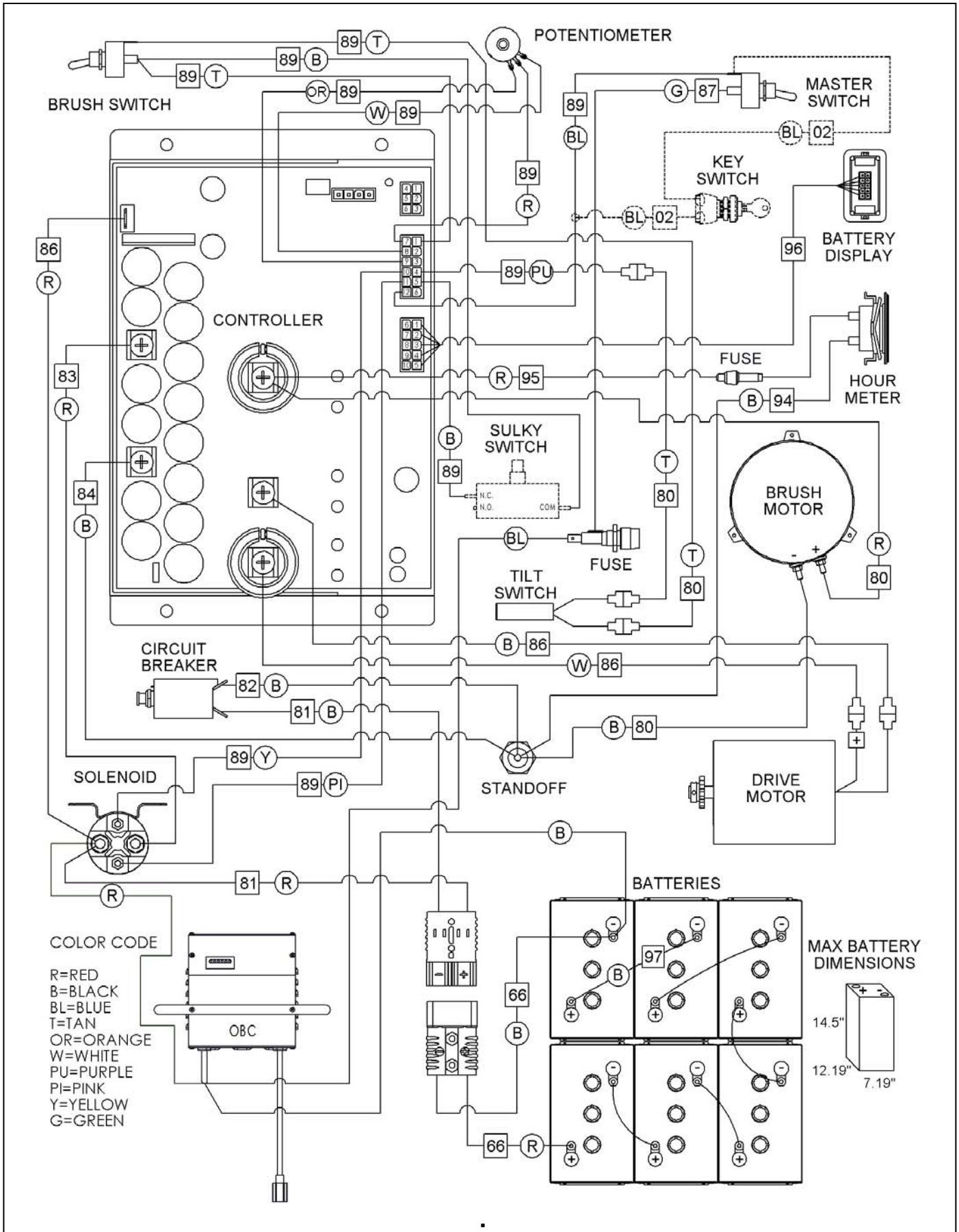

HEAD MOTOR

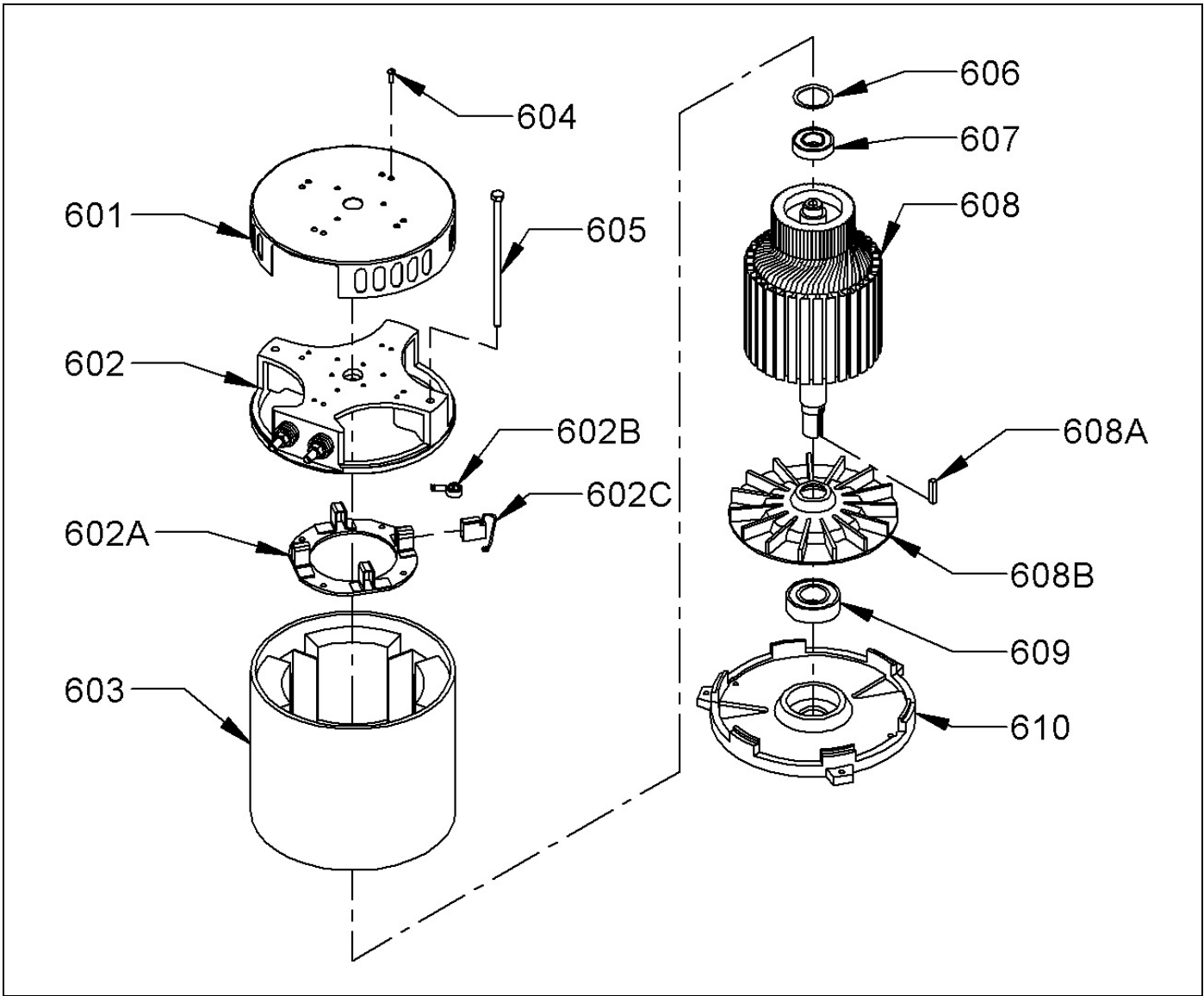

<u>ITEM</u>	<u>PART NO.</u>	<u>DESCRIPTION</u>	<u>QTY</u>
	6499001	MOTOR, PAD, 29 VOLT, P66LR015 - INCLUDES:	1
601	5991731	COMMUTATOR BRACKET COVER	1
602	6493531	COMMUTATOR BRACKET ASSEMBLY - INCLUDES:	1
602	6493541	COMMUTATOR BRACKET	1
602A	6498951	BRUSH BOARD ASSEMBLY - INCLUDES:	1
602B	6493591	SPRING	4
602C	7692041	CARBON BRUSH	4
603	6498961	STATOR FRAME ASSEMBLY - WITH CLIPS AND MAGNETS - 3 HP	1
604	9120600	#10-24 X 1/2 PAN HEAD PHILLIPS THREAD CUTTING SCREW - PK 10	4
605	6493621	1/4-20 X 9 HEX HEAD THRU BOLT - 3 HP	2
606	-----	HELICAL WASHER - LARGE	1
607	5991551	BEARING - TOP END	1
608	6498971	ARMATURE - 2100 RPM - 3.6 HP - INCLUDES:	1
608A	9120827	3/16 SQUARE X 1 LONG KEY - STEEL - PACK OF 2	1
608B	6493571	ALUMINUM FAN	1
609	5991541	BEARING - BOTTOM END	1
610	6493551	END BRACKET - BOTTOM END	1

DRIVE MOTOR

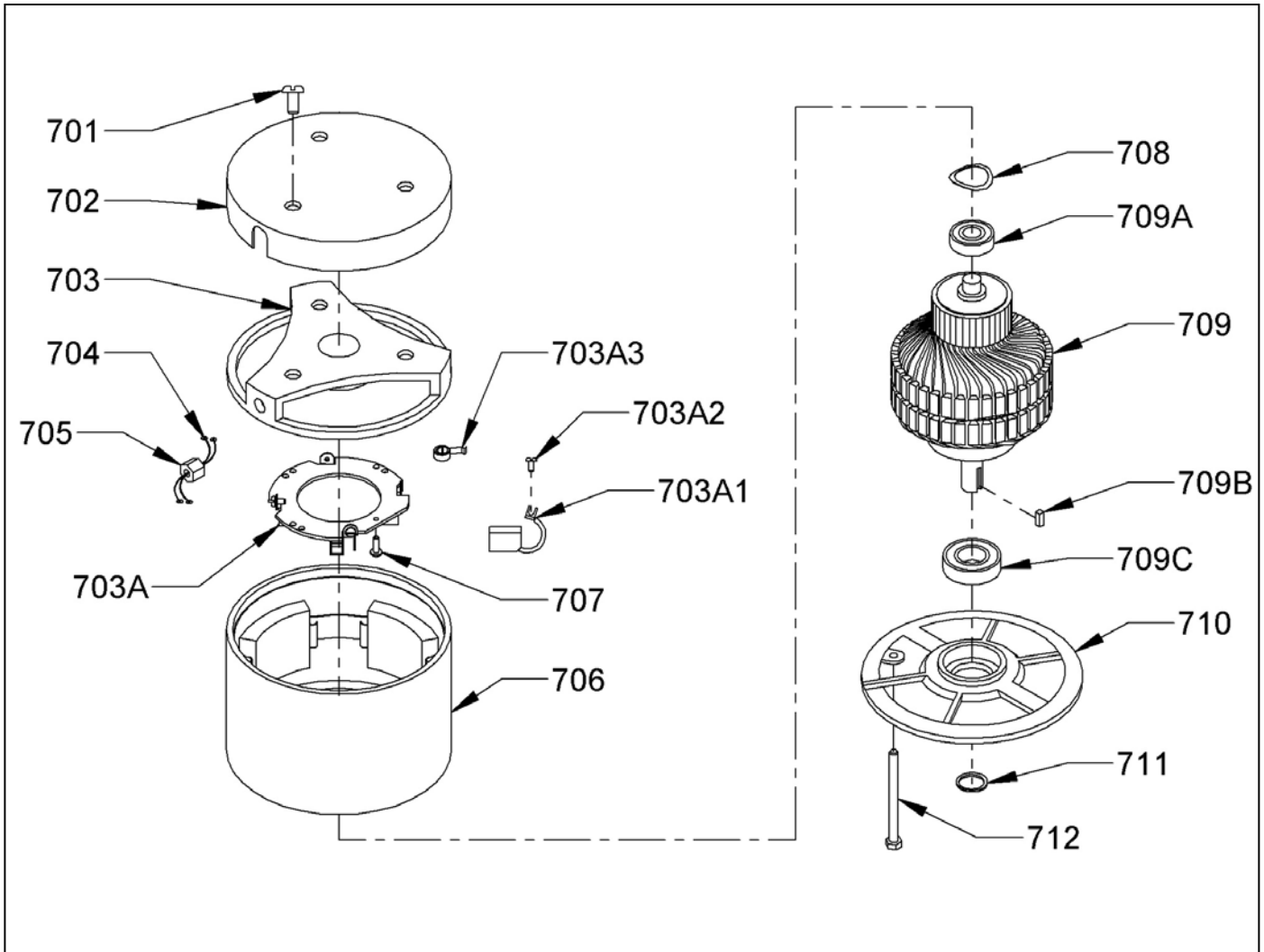

<u>ITEM</u>	<u>PART NO.</u>	<u>DESCRIPTION</u>	<u>QTY</u>
	2790101	DRIVE MOTOR ASSEMBLY 36 VOLT - INCLUDES:	1
701	-----	PAN HEAD SCREW	3
702	2797721	TOP COVER	1
703	-----	TOP END BELL ASSEMBLY	1
703A	2797681	BRUSH BOARD ASSEMBLY - INCLUDES:	1
703A1	2797571	BRUSH SPRING	4
703A2	-----	#10-32 X 3/8 BRASS PAN HEAD SCREW	4
703A3	2797691	CARBON BRUSH WITH LEAD AND TERMINAL	4
704	2797581	LEAD ASSEMBLY - 1 WIRE WITH TERMINALS	2
705	-----	HEYCO STRAIN RELIEF	1
706	2797651	STATOR FRAME ASSEMBLY WITH MAGNETS	1
707	9120600	#10-24 X 1/2 SELF TAPPING ROUND HEAD SCREW - PACK OF 10	3
708	2797591	HELICAL WASHER	1
709	2797661	ARMATURE ASSEMBLY - INCLUDES:	1
709A	5092041	BEARING TOP END - COMMUTATOR END	1
709B	2792681	SHAFT KEY	1
709C	2790311	BEARING, BOTTOM END (SHAFT END)	1
710	2797711	BOTTOM END BELL	1
711	2797731	SHAFT SEAL	1
712	-----	THRU BOLT	2

ACCESSORIES

<u>PART NO.</u>	<u>DESCRIPTION</u>
-----------------	--------------------

NOTE:	ALL PADS COME 5 PADS PER CASE (EXCEPT TWISTER PADS)
7992751	27" LITE BLUE POLISH / BURNISH PAD - FOR SOFT FINISH
7992781	27" ULTRA HAIR HARD FINISH PAD - FOR HARD FINISH
7992821	27" BEIGE PLUS UHS SCRUB PAD - FOR SCUFF MARK



<u>BATTERY & BATTERY CHARGER</u>	
--------------------------------------	--

2698441	DUAL PRO CHARGER FAN REFURBISHMENT KIT
2698421	DUAL PRO CHARGER RING TERMINAL REFURBISHMENT KIT
9123220	BATTERY TERMINAL BOOT



NSS® Enterprises, Inc.

3115 Frenchmens Road
Toledo, Ohio 43607
PHONE (419) 531-2121
FAX (419) 531-3761
mailus@nss.com
www.nss.com