

Carpetriever™ 28

Parts List

11/1999 revised 12/2019 REV D
Form no. 56042384

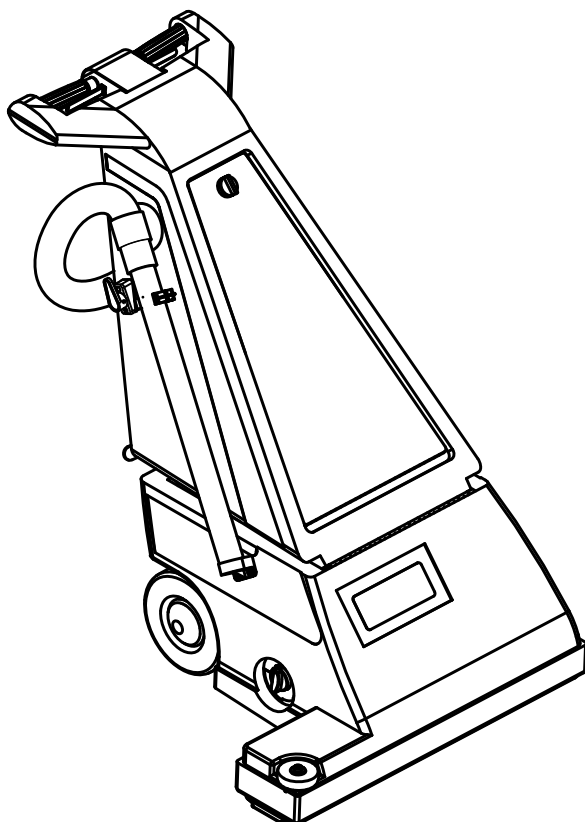

Active Model:
56330020(120V)
Obsolete Model:
56330925(100V)

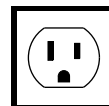

TABLE OF CONTENTS

DESCRIPTION	PAGE
Base System	2-3
Brush Motor Assembly	4-5
Decal System	6-7
Handle System-1 (Before SN1875350)	8-9
Handle System-2 (Before SN1875350)	10-11
Handle System-1 (After SN1875349)	12-13
Handle System-2 (After SN1875349)	14-15
Wiring Diagram - 120v	16-17
Wiring Diagram - 100v	18-19

WHEN ORDERING PARTS

- * Use the part numbers from the "Ref. No." columns in this parts list.
- * Specify the model and serial number of the machine.
- * Use the space below to record the model and serial number for future reference.

Model _____ **Serial No.** _____

BASE SYSTEM

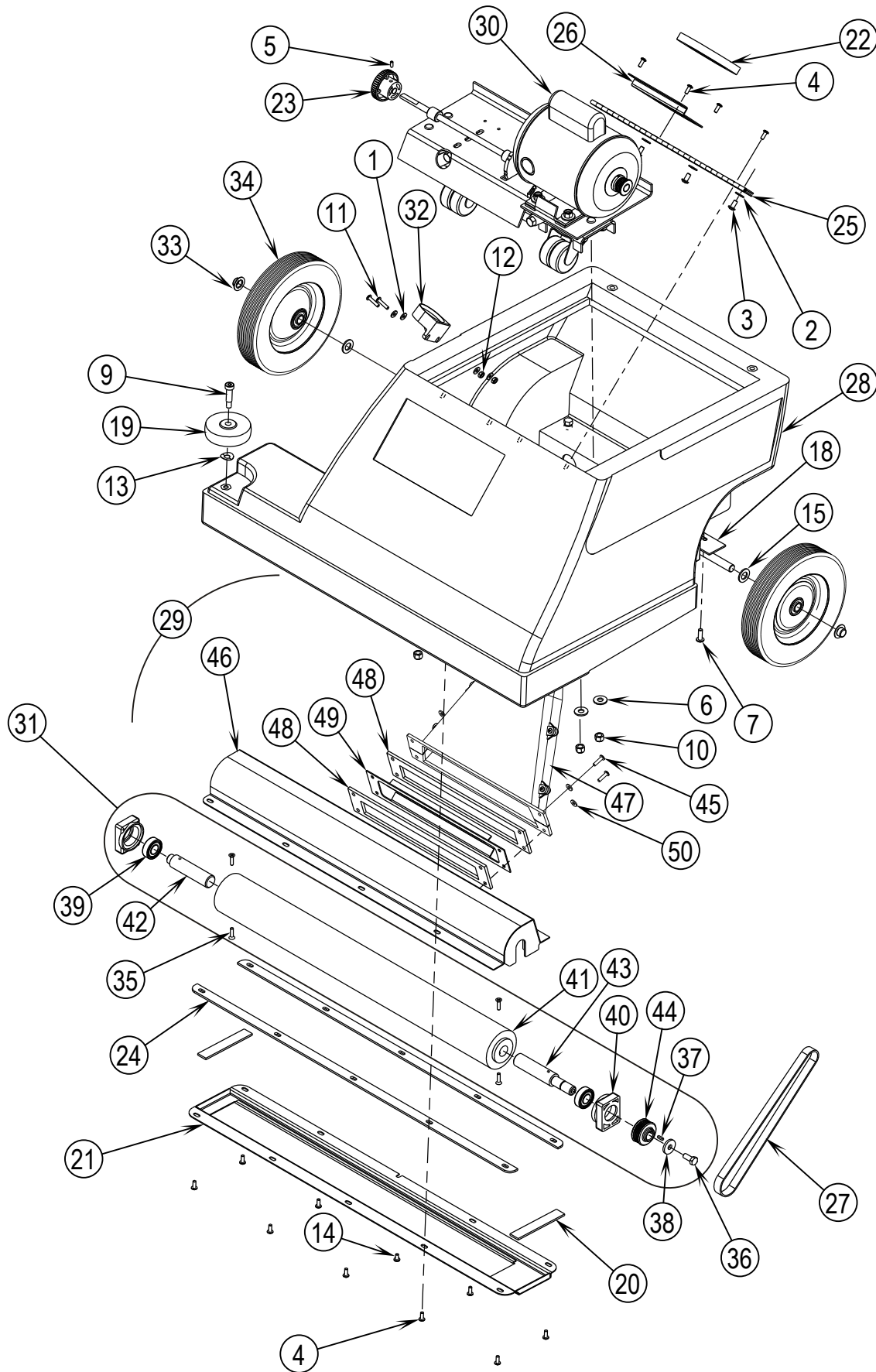

BASE SYSTEM

Item	Ref. No.	Qty	Description
1	56001954	4	Washer, Flt SAE #10
2	56002098	4	Washer, Flt SAE 1/4
3	56002145	4	Screw, Pan Phil 1/4-20 x .50
4	56002147	13	Screw, Pan Phil (UNF) 10-32 x .50
5	56003123	1	Screw, Soc Set 10-24 x .38
6	56002220	4	Washer, Flt STD 5/16
7	56002066	2	Screw, Pan Phil 1/4-20 x .62
9	56003472	1	Screw, Soc Shd .38 x 1.00 x 5/16-18
10	56002826	4	Nut, Hex Nyl Loc Thin 5/16-18
11	56002733	2	Screw, Pan Phil 10-24 x .88
12	56002832	2	Nut, Hex Nyl Loc-Thin 10-24
13#	80317A	1	Washer, Bowed .406 x .688 x .125
14	56003735	1	Screw Pan Phil Type A 10X.50
15	56009003	4	Washer, Flt .516 x .938 x .075 TSBUS2002-798
18	56330045	1	Weldment, Axle TSBUS2002-798
19	56049261	1	Wheel
20	56052279	2	Foam Gasket Strip
21	56381747	1	Plate-Bottom 28 Upright
22	56055054	1	Gasket, Foam
23	56475480	1	Knob
24	56055187	2	Gasket, Foam
25	56055213	1	Hinge, Butt
26	56055217	1	Bracket, Intake Tube
27	56055123	1	Belt, V
28	56330010	1	Tank, Base
29	56330011	1	Brush Housing Assembly (45-50) TSBUS2002-808
30	56330012	1	Brush Motor Assy (120V / see associated pages)
		1	Brush Motor Assy (100V / see associated pages)
31	56330015	1	Brush Assembly (35-44) TSBUS2002-808
32	56331151	1	Holder, Tube
33	56009097	2	Nut, Push Cap 1/2 TSBUS2002-798
34	56330051	2	Wheel TSBUS2002-798 / NOTE 1
	56330015	1	Brush Assembly
35	56001900	4	Screw, Flt Phil 10-24 x .75
36	56002956	1	Screw, Hex Hd Loc 5/16-18 x .75
37	56003235	1	Key, Sq. .12 x .44
38	56001939	1	Washer, Flt SAE 5/16
39	56027222	2	Bearing, Ball
40	56055030	2	Mount, Bearing
41	56055126	1	Brush, Cylinder
42	56055127	1	Shaft, Brush
43	56330014	1	Shaft, Brush
44	56330914	1	Sheave, Poly V Belt
	56330011	1	Brush Housing Assembly
45	56002192	4	Screw, Pan Phil 10-24 x .75
46	56034673	1	Weldment, Brush Housing
47	56055121	1	Tube, Intake Machined
48	56055122	2	Gasket
49	56055615	1	Plate
50	56001954	4	Washer-Flt SAE 10

NOTE 1: Wheel 56330051 has replaced 56210148 in production.

= Revised or new since last update

BRUSH MOTOR ASSEMBLY

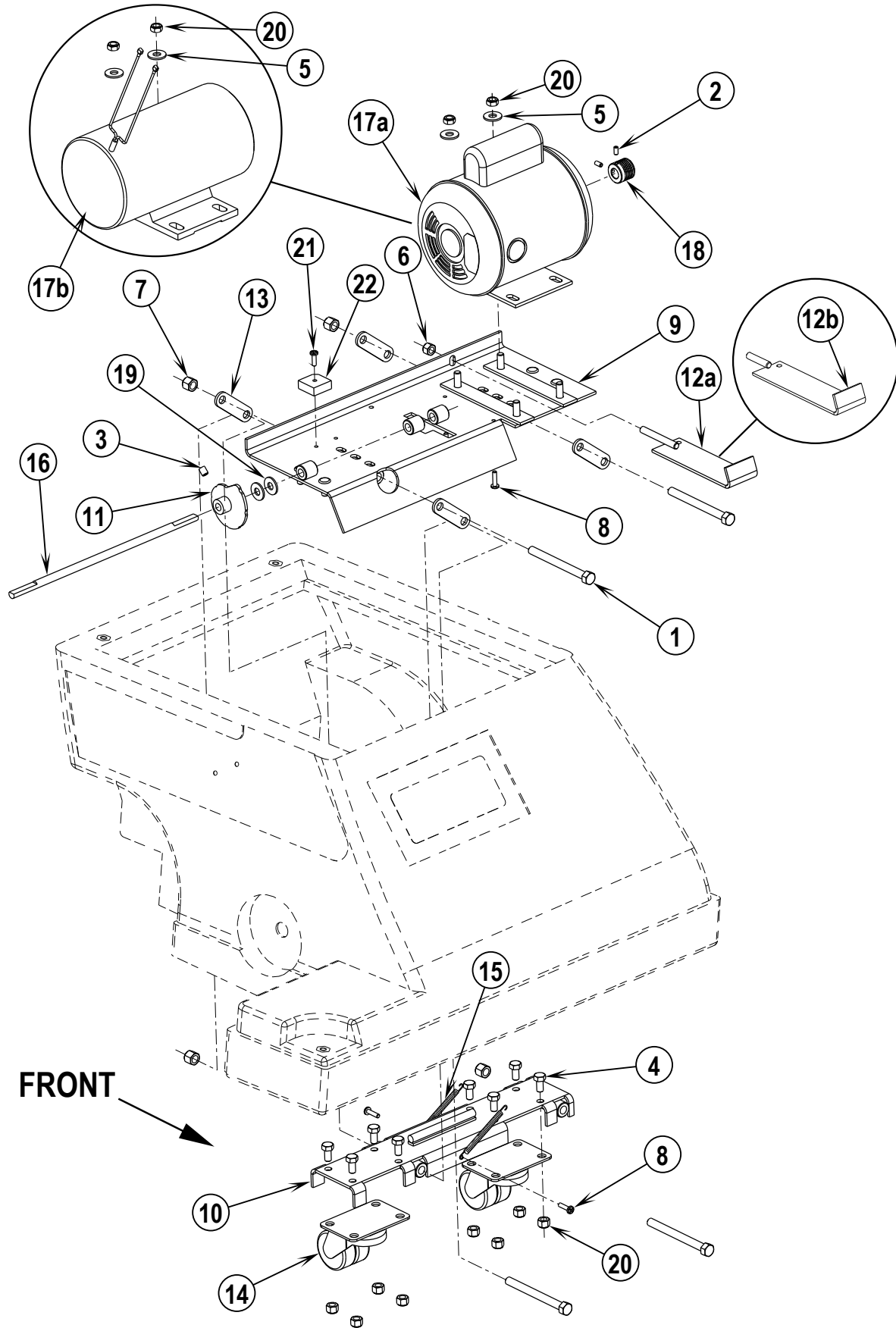

BRUSH MOTOR ASSEMBLY

Item	Ref. No.	Qty	Description
1	56001819	4	Scr. Hex Hd 3/8-16 x 4.00
2	56001823	2	Scr. Soc Set Loc 10-24 x .38
3	56002021	1	Scr. Soc Set Loc 5/16-18 x .38
4	56002035	8	Scr. Hex Hd 5/16-18 x .62
5	56002220	2	Wsh. Flt STD 5/16
6	56002701	1	Nut. Hex Nyl Loc 5/16-18
7	56002769	4	Nut. Hex Nyl Loc 3/8-16
8	56009043	4	Scr. Pan Phil Thd Form 10-24 x .75
9	56034675	1	Weldment, Bracket, Motor (120V)
		1	Weldment, Bracket, Motor (100V)
10	56034677	1	Caster Bracket Weldment
11	56034679	1	Weldment, Cam Height Adjustment
12a	56034691	1	Weldment, Adjustment Bracket (120V)
12b		1	Weldment, Adjustment Bracket (100V)
13	56055031	4	Steel, Bar
14	56055134	2	Caster, 2.00 Dia.
15	56055135	2	Spring
16	56055137	1	Shaft, Height Adjustment
17a	56384573	1	Motor-115/230V-1725RPM-1/3hp (120V)
*	56384521	1	Motor Brush Kit-2538049
17b		1	Motor, 1/3hp (100V)
*	56330928	2	Brush, Carbon for 56330926
*	56330929	2	Brush, Spring for 56330926
*	56330930	2	Brush, Access Cover for 56330926
18	56330016	1	Sheave, Poly V Belt
19	56002220	2	Wsh. Flt STD 5/16 (100V)
20	56002826	10	Nut, Hex nyl Loc-Thin 5/16-18
21	56009042	1	Scr. Pan Phil Thd Form 10-24 x .62 (100V)
22	56180163	1	Rectifier, 40 Amp (100V)

* = Not Shown

DECAL SYSTEM

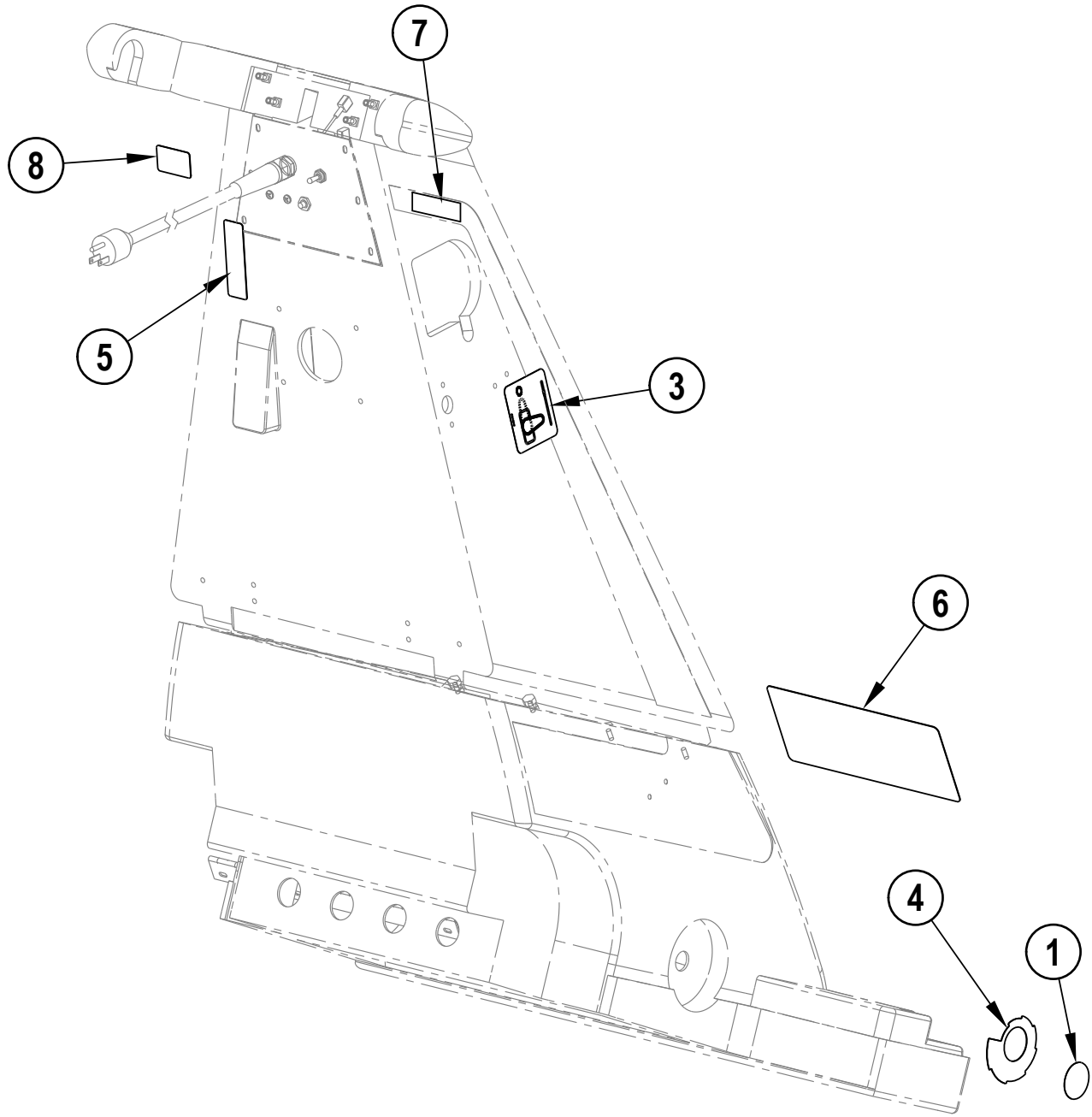

DECAL SYSTEM

Item	Ref. No.	Qty	Description
1	56015188	1	Decal, Knob
3	56016619	1	Decal, Wand (After May 2005)
4	56057686	1	Label, Height Adjust
5	56630714	1	Label, Warning
6	56016476	1	Decal, Carpetriever 28
7	56016475	1	Decal, Wand (Before June 2005)
8#	56394259	1	Decal-Prop 65
*	56014119	6	Decal, Ground Symbol

* = Not Shown

= Revised or new since last update

HANDLE SYSTEM-1 - BEFORE SN1875350

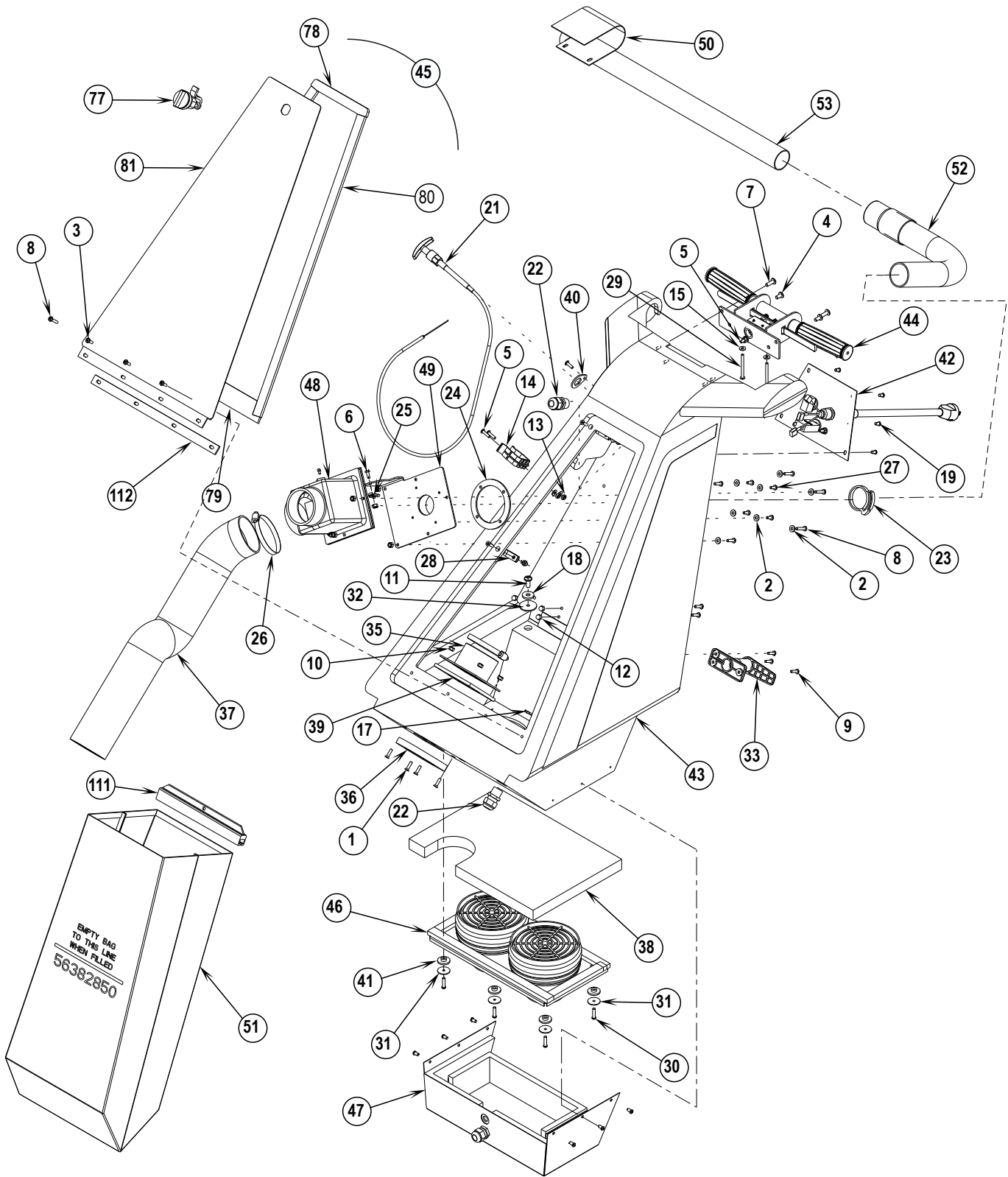

HANDLE SYSTEM-1 - BEFORE SN1875350

Item	Ref. No.	Qty	Description
1	56001900	6	Scr, Flt Phil 10-24 x .75
2	56001954	11	Wsh, Flt SAE #10
3	56002124	3	Scr, Pan Phil 10-24 x .62
4	56002145	2	Scr, Pan Phil 1/4-20 x .50
5	56002192	4	Scr, Pan Phil 10-24 x .75
6	56002503	1	Scr, Hex Hd 10-24 x .50
7	56002507	2	Scr, Pan Phil 1/4-20 x .75
8	56002674	4	Scr, Pan Phil 10-24 x 1.00
9	56001993	6	Scr, Pan Phil 10-24 x 1.00
10	56002768	17	Nut, Hex Nyl Loc 10-24
11	56002793	2	Scr, Pan Phil 5/16-18 x .75
12	56009061	6	Nut, Acorn SS 10 x 24
13	56002832	2	Nut, Hex Nyl Loc-Thin 10-24
14	56331154	1	Clamp, Plastic
15	56009011	2	Wsh, Int SHPRF #10
17	56009095	2	Nut, Conduit Lock 1/2-14
18	56009122	2	Wsh, Flt .344 x .938 x .125
19	56009247	12	Scr, Pan Phil Plastite 10-14 x .38
21	56331349	1	Control Cable
22	56323135	2	Strain Relief
23	56331304	1	Clamp, Hose
24	56330909	1	Gasket
25	56344265	1	Clamp, Cable
26	56352829	2	Clamp, Hose SAE #52
27	56009029	4	Scr, Pan Phil Thd Form 10-24 x .50
28	56385564	3	Clamp, P
29	56003503	2	Scr, Pan Phil 10-24 x 2.25
30	56003504	6	Scr, Pan Phil Plastite 10-14 x .88
31	56009268	6	Wsh, Flt .187 x 1.00 x .062
32	56009275	2	Washer, Neoprene
33	56171112	2	Cord Hook Assy
35	56034690	1	Weldment, Hose Connector
36	56055054	1	Gasket, Foam
37	56055081	1	Hose, Vac
38	56055084	1	Guard, Bag
39	56055182	1	Gasket, Foam
40	56330921	1	Plate
41	56111384	6	Rubber Bushing
42	56330918	1	Electrical Assy (54-63) (120V)
	56330932	1	Electrical Assy (54-63) (100V)
43	56330003	1	Tank, Upper Machined
44	56330005	1	Handle Assembly (64-75)
45	56330006	1	Door Assembly (77-81)
46	56330007	1	Vacuum Motor Assy (120V) (82-90, 106-109)
	56330937	1	Vacuum Motor Assy (100V) (82-90, 106-109)
47	56330008	1	Muffler Assembly (91-95)
48		1	Butterfly Assembly (96-105)
49	56330021	1	Tube Weldment
50	56639107	1	Switchbox Cover Weldment
51	56382850	1	Bag Collector
*	56330690	1	Paper Bag (package of 6 / optional)
52	56331152	1	Hose Assy
53	56331153	1	Wand
111	56330608	1	Bag Clip (for 56382850)
112	56055218	1	Gasket, Foam

* = Not Shown

HANDLE SYSTEM-2 - BEFORE SN1875350

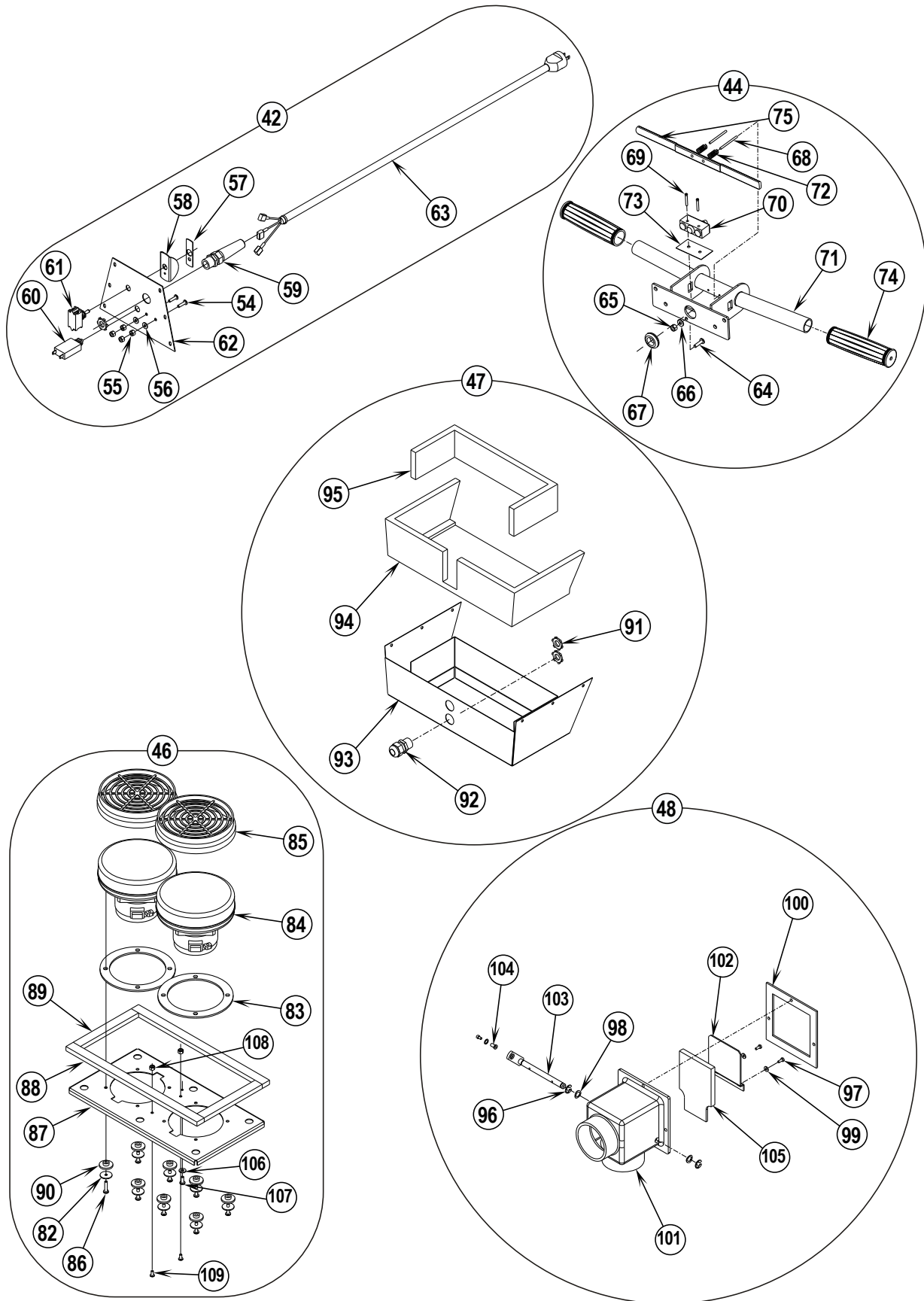

HANDLE SYSTEM-2 - BEFORE SN1875350

Item	Ref. No.	Qty	Description
42	56330918	1	Electrical Assy (54-63) (120V)
	56330932	1	Electrical Assy (54-63) (100V)
44	56330005	1	Handle Assembly (64-75)
46	56330007	1	Vacuum Motor Assy (120V) (82-90, 106-109)
	56330937	1	Vacuum Motor Assy (100V) (82-90, 106-109)
47	56330008	1	Muffler Assembly (91-95)
48		1	Butterfly Assembly (96-105)
54	56002192	2	Scr. Pan Phil 10-24 x .75
55	56009009	4	Nut, Hex Machine 10-24
56	56009011	2	Wsh, Int SHPRF #10
57	56014016	1	Decal, On/Off (100V)
58	56200352	1	Guard Switch (100V)
59	56323136	1	Strain Relief
*	56009095	1	Nut, Conduit Lock 1/2-14
60	56387316	1	Circuit Breaker, 10 Amp
61	56301636	1	Switch, Toggle (100V)
	56026973	1	Switch, Toggle (120V)
62	56643059	1	Cover, Access
63	56637610	1	Cord Set (120V)
*	56330042	1	Power Cord (100V)
64	56002192	1	Scr. Pan Phil 10-24 x .75
65	56009009	1	Nut, Hex Machine 10-24
66	56009011	1	Wsh, Int SHPRF #10
67	56497610	1	Grommet
68	56003502	2	Pin
69	56002857	2	Scr. Pan Phil 6-32 x .88
70	56026412	1	Switch, Push
71	56034663	1	Weldment, Handle
72	56046648	2	Spring
73	56046653	1	Insulation Paper
74	56381707	2	Handle Grip
75	56050274	1	Trigger
77	56055050	1	Latch, Twist
78	56055051	1	Gasket, Foam
79	56055052	1	Gasket, Foam
80	56055053	2	Gasket
81	56639110	1	Weldment, Door
82	56009096	8	Wsh, Flt .193 x .875 x .060
83	56209325	2	Gasket
84	56325096	2	Vacuum Motor (120V)
	56330389	2	Vacuum Motor (100V)
*	56220065	2	Carbon Brush Set for 56325096 & 56330389
*	56009030	2	Scr. Pan Phil Thd Form 10-24 x .38 (100V)
85	56384898	2	Filter
**	56383934	1	Microstat Filter Kit (pkg of 2)
86	56003505	8	Scr. Pan Phil Thd Form 10-24 x .88
87	56055023	1	Plate, Mount Vac Motors
88	56055041	2	Gasket, Foam
89	56055042	2	Gasket, Foam
90	56111384	8	Rubber Bushing
91	56009095	2	Nut, Conduit Lock 1/2-14
92	56323135	2	Strain Relief
93	56034668	1	Weldment, Muffler
94	56055117	1	Gasket, Foam
95	56055118	1	Gasket, Foam
96	56003269	2	Ring, Ret Ext Type E Reinf. .38 Dia.
97	56009032	2	Scr. Hex Thd Form 6-32 x .38
98	56009045	2	Wsh, Bowed .375 x .578 x .060
99	56009056	2	Wsh, Int SHPRF #6
100		1	Gasket
101		1	Housing
102		1	Plate
103		1	Lever Weldment
104	56442445	1	Swivel Wire
105		1	Seal
106	56009011	1	Wsh, Int SHPRF #10 (3 on 100V)
107	56009029	1	Scr. Pan Phil Thd Form 10-24 x .50
108	56002808	2	Nut, Hex Nyl Loc 8-32
109	56001818	2	Scr. Pan Phil 8-32 x .38

* = Not Shown

** = Optional

HANDLE SYSTEM-1 - AFTER SN1875349

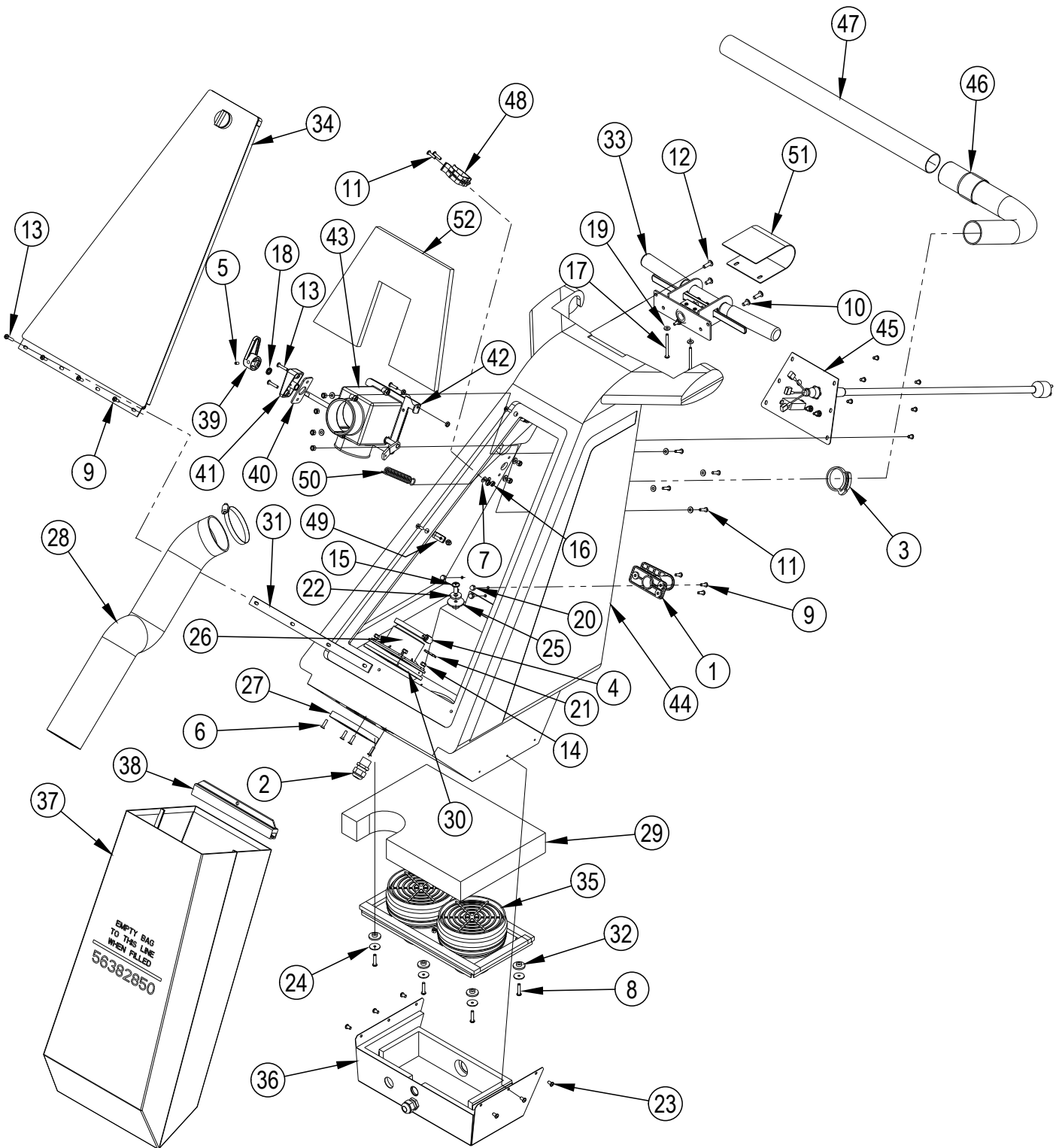

HANDLE SYSTEM-1 - AFTER SN1875349

Item	Ref. No.	Qty	Description
1	56171112	2	Cord Hook Assy
2	56323135	2	Strain Relief
3	56331304	1	Clamp, Hose
4	56352829	2	Clamp, Hose SAE #52
5	56003123	1	Scr-Soc Set 10-24 x .38
6	56001900	6	Scr, Flt Phil 10-24 x .75
7	56001954	10	Wsh, Flt SAE #10
8	56003112	6	Scr-Pan Phil Plastite 10-14 x 1.00
9	56002124	9	Scr, Pan Phil 10-24 x .62
10	56002145	2	Scr, Pan Phil 1/4-20 x .50
11	56002192	6	Scr, Pan Phil 10-24 x .75
12	56002507	2	Scr, Pan Phil 1/4-20 x .75
13	56002674	3	Scr, Pan Phil 10-24 x 1.00
14	56002768	16	Nut, Hex Nyl Loc 10-24
15	56002793	2	Scr, Pan Phil 5/16-18 x .75
16	56002832	2	Nut, Hex Nyl Loc-Thin 10-24
17	56003503	2	Scr, Pan Phil 10-24 X 2.25
18	56003706	1	O-Ring, Quad
19	56009011	2	Wsh, Int Shprf #10
20	56009061	6	Nut, Acorn SS 10 x 24
21	56009095	2	Nut, Conduit Lock 1/2-14
22	56009122	2	Wsh, Flt .344 x .938 x .125
23	56009247	12	Scr, Pan Phil Plastite 10-14 x .38
24	56009002	6	Washer Flat .266X.906X.060
25	56009275	2	Washer, Neoprene
26	56034690	1	Hose Connector
27	56055054	1	Gasket, Foam
28	56055081	1	Hose, Vac
29	56055084	1	Guard, Bag
30	56055182	1	Gasket, Foam
31	56055218	1	Gasket, Foam
32	56111384	6	Rubber Bushing
33	56330005	1	Handle Assembly
34	56330006	1	Door Assembly
	56055050	1	Latch, Twist
	56055051	1	Gasket, Foam
	56055052	1	Gasket, Foam
	56055053	2	Gasket
	56639110	1	Weldment, Door
35	56330007	1	Vacuum Motors Assy
36	56330008	1	Muffler Assembly
37	56382850	1	Bag Collector
*	56330690	1	Paper Bag (package of 6 / optional)
38	56330608	1	Bag Clip for (56382850)
39	56330821	1	Lever
40	56330822	1	Gasket, Base
41	56330823	1	Base, Lever Mount
42	56330827	1	Bracket, Spring Mount
43	56330830	1	Vacuum Diverter Assembly
44	56330835	1	Tank, Upper Machined
45	56330918	1	Electrical Assy
46	56331152	1	Hose Assembly, Vac
47	56331153	1	Wand
48	56331154	1	Clamp, Plastic
49	56385564	3	Clamp, P
50	56448112	1	Spring Ext
51	56639107	1	Weld't, Switchbox Cover
52	56380337	1	Guard Panel Foam TSBUS2009-1053

* = Not Shown

HANDLE SYSTEM-2 - AFTER SN1875349

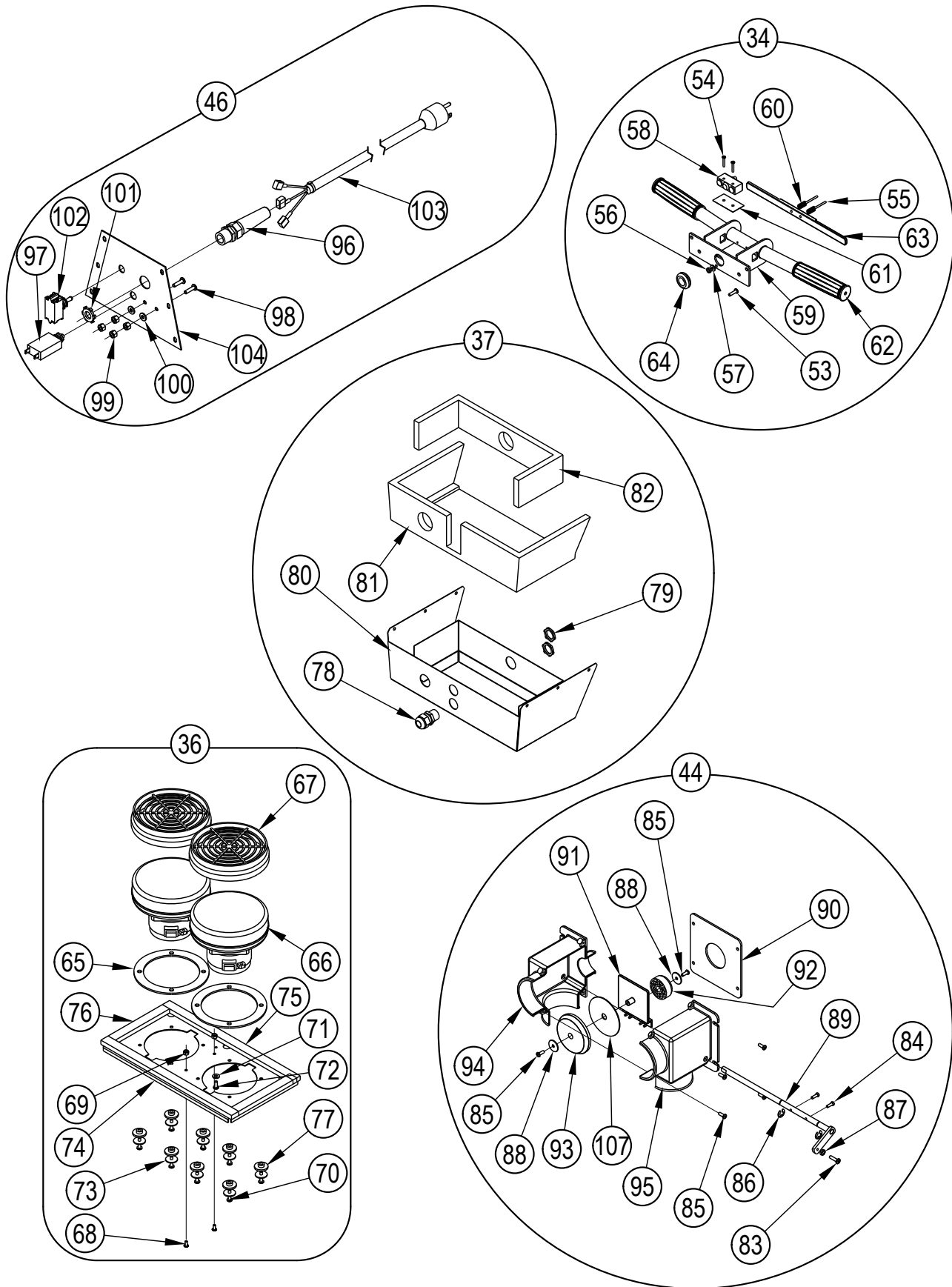

HANDLE SYSTEM-2 - AFTER SN1875349

Item	Ref. No.	Qty	Description	44	56330830	1	Vacuum Diverter Assy (83-95, 107)
34	56330005	1	Handle Assy (53-64)	83	56002192	1	Scr. Pan Phil 10-24 x .75
53	56002192	1	Scr. Pan Phil 10-24 x .75	84	56002438	2	Scr. Hex Thd Form 8-32 x .50
54	56002857	2	Scr. Pan Phil 6-32 x .88	85	56003093	6	Scr. Pan Phil Plastite 8-16 x .50
55	56003502	2	Pin	86	56003269	2	Ring, Ret Ext Type E Reinf. 0.38 Dia
56	56009009	1	Nut, Hex Machine 10-24	87	56009009	1	Nut, Hex Machine 10-24
57	56009011	1	Wsh, Int Shprf #10	88	56009096	2	Wsh, Flt .193 x .875 x .060
58	56026412	1	Switch, Push	89	56330824	1	Shaft Weldment
59	56034663	1	Weldment, Handle	90	56330828	1	Gasket, Housing
60	56046648	2	Spring	91	56330829	1	Plate, Diverter
61	56046653	1	Insulation Paper	92	56330831	1	Seal, Wand Vacuum
62	56381707	2	Handle Grip	93	56330832	1	Seal, Brush Vacuum
63	56050274	1	Trigger	94	56330833	1	Housing, Left Half
64	56760212	1	Grommet	95	56330834	1	Housing, Right Half
				107	56330837	1	Spacer Plate
36	56330007	1	Vacuum Motors Assy (65-77)	46	56330918	1	Electrical Assy (96-104)
65	56209325	2	Gasket	96	56323136	1	Strain Relief
66	56325096	2	Vacuum Motor	97	56387316	1	Circuit Breaker, 10 Amp
*	56220065	2	Carbon Brush Set for 56325096 & 56300411	98	56002192	2	Scr. Pan Phil 10-24 x .75
67	56384898	2	Filter	99	56009009	4	Nut, Hex Machine 10-24
**	56383934	1	Microstat Filter Kit (pkg of 2)	100	56009011	2	Wsh, Int Shprf #10
68	56001818	2	Scr. Pan Phil 8-32 x .38	101	56009095	1	Nut, Conduit Lock 1/2-14
69	56002808	2	Nut, Hex Nyl Loc 8-32	102	56026973	1	Switch, Toggle
70	56009209	8	Scr-Pan Phil Thd Form 10-24X1.00	103	56637610	1	Cord Set
71	56009011	1	Wsh, Int Shprf #10	104	56643059	1	Cover, Access
72	56009029	1	Scr. Pan Phil Thd Form 10-24 x .50				
73	56009096	8	Wsh, Flt .193 x .875 x .060				
74	56055023	1	Plate, Mtg Vac Motors				
75	56055041	2	Gasket, Foam				
76	56055042	2	Gasket, Foam				
77	56111384	8	Rubber Bushing				
37	56330008	1	Muffler Assy (78-82)				
78	56323135	1	Strain Relief				
79	56009095	2	Nut, Conduit Lock 1/2-14				
80	56034668	1	Weldment, Muffler				
81	56055117	1	Gasket, Foam				
82	56055118	1	Gasket, Foam				

* = Not Shown

** = Optional

Item	Ref. No.	Qty	Description
-------------	-----------------	------------	--------------------

WIRING DIAGRAM - 120V

Item	Ref. No.	Qty	Description
F1	56387316	1	Circuit Breaker, 10 Amp
J1	56637610	1	Cord Set, 120V
M1	56325096	1	Vacuum Motor
*	56220065	2	Carbon Brush Set for 56325096
M2	56325096	1	Vacuum Motor
*	56220065	2	Carbon Brush Set for 56325096
M3	56330013	1	Brush Motor, 1/3hp
*	56755056	1	Replacement Capacitor for 56330013
S1	56026973	1	Main Switch
S2	56026412	1	Brush Switch

* = Not Shown

WIRING DIAGRAM - 100V

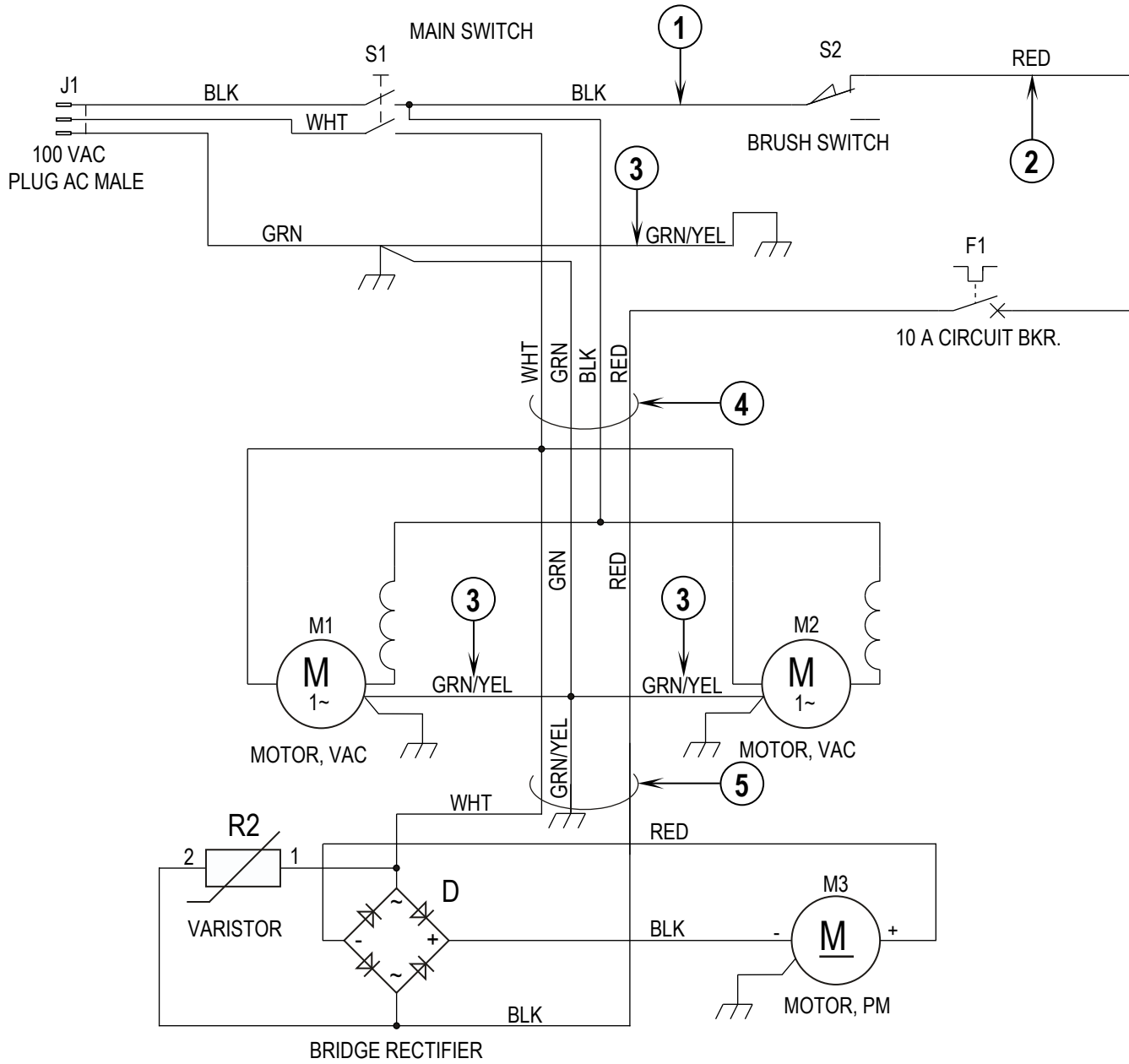

WIRING DIAGRAM - 100V

Item	Ref. No.	Qty	Description
F1	56387316	1	Circuit Breaker, 10 Amp
J1	56330042	1	Power Cord, 100V
M1	56330389	1	Vacuum Motor
*	56220065	2	Carbon Brush Set for 56330389
M2	56330389	1	Vacuum Motor
*	56220065	2	Carbon Brush Set for 56330389
M3	NA	1	Brush Motor, 1/3hp
*	56330928	2	Carbon Brush Set for 56330926
*	56330929	2	Brush, Spring for 56330926
*	56330930	2	Brush, Access Cover for 56330926
R2	56387554	1	Varistor Assembly
S1	56301636	1	Main Switch
S2	56026412	1	Brush Switch
1	56025902	1	Wire, Ring/Piggy Back terminal
2	56025648	1	Wire, Ring/Female Receptacle
3	56250150	3	Wire, Ring/Ring
4	56330017	1	Cord Assembly 14-4
5	56025903	1	Cable, Electric
*	56163228	3	Connector, Wire

* = Not Shown

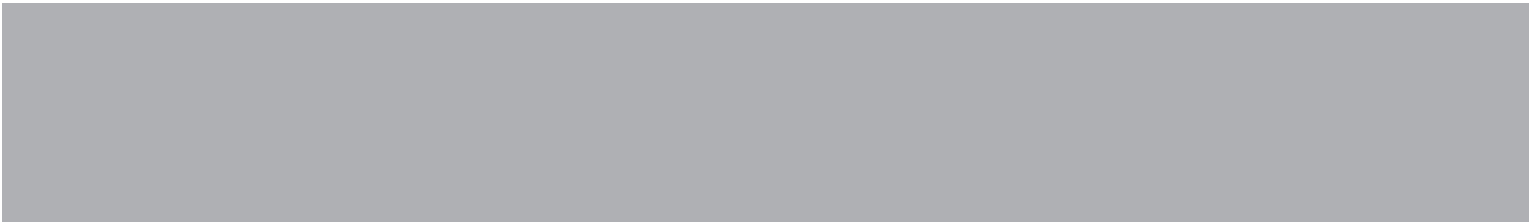

9435 Winnetka Ave North
Minneapolis, MN 55445
www.advance-us.com
Phone: 800-989-2235
Fax: 800-989-6566
©2019 Nilfisk, Inc.

