

## VF150

### CAST IRON VORTEX SUBMERSIBLE DRAINAGE PUMP



VF150



#### FEATURES

- Strong durable cast iron pump body.
- 15mm soft solids passable.
- Vortex impeller.
- Lip seal and dual mechanical seal.
- Float switch.
- Moisture sealed cable inlet.
- Max head -7m.
- Max flow - 150lpm.

#### APPLICATIONS

- Disposal of waste water, septic effluent water and grey water of a neutral pH.
- Dewatering (clean water).
- Water treatment circulation.

#### PUMP INFORMATION

Vertical, single-stage, submersible pump capable of pumping soft solids up to 15mm in diameter. Polycarbonate vortex impeller with cast iron casing, feet and 1¼" BSP (female) discharge port. 304SS motor casing.

<b>Pump casing:</b>	Cast iron.
<b>Impeller:</b>	Polycarbonate.
<b>Motor shaft:</b>	304SS.
<b>Mechanical seal:</b>	Carbon ceramic mechanical seal and lip seal.
<b>IP Rating:</b>	IP68.

#### OPERATING CONDITIONS

Drainage pump for the disposal of waste water, including rainwater, septic effluent water and grey water of neutral pH containing soft particles up to 15mm diameter. Install pump vertically (hose connection possible).

Fluid:	Water.
Maximum water temperature:	40°C.
Minimum water temperature:	1°C.
Maximum submergence:	6m.
Pump on level (factory set):	500mm.
Pump off level:	75mm.

## ELECTRICAL DATA

Type	Type of current	Voltage ± 10%	Frequency Hz	Motor rating kW		RPM min	Locked rotor current Ampere	Current Ampere	Motor protection	Insulation class	Cable length
				P1	P2						
VF150	1-phase	230	50		.18	2850	9.5	1.75			6 m

## DIMENSIONS

Type	Maximum L x W x H	Weight approx.	Packed L x W x H	Packed weight	Discharge branch	Free passage	Continuous operating temperature range
VF150	122 x 165 x 357 mm	9kg	200 x 200 x 380 mm	10kg	1¼" BSP (female)	10 mm	1° - 40°

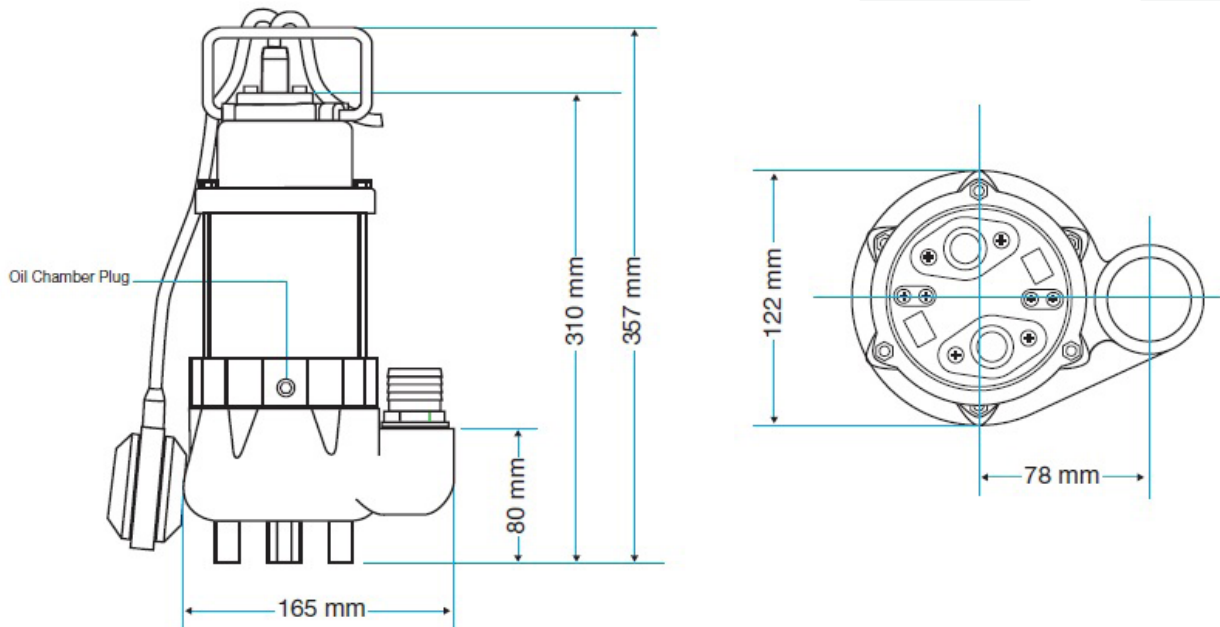

## PERFORMANCE

Type	P/No	Delivery head H [m]	1	2	3	4	5	6
VF150	VF150	Flow rate capacity [lpm]	-	128	106	78	47	19

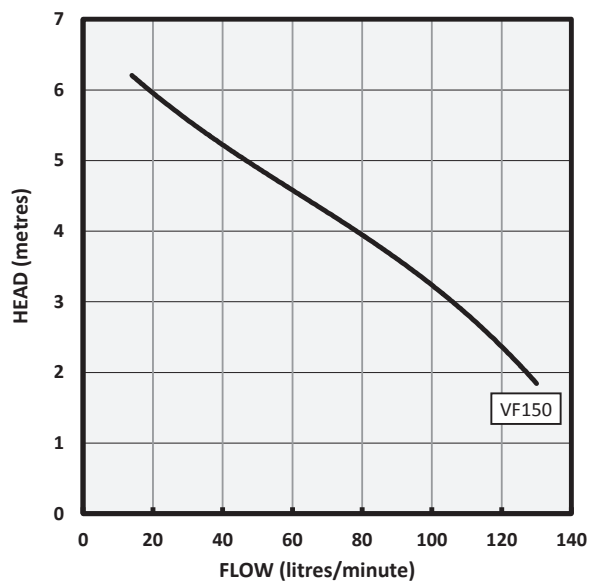

Head Office Pentair AU/NZ: 1-21 Monash Drive, Dandenong South, VIC 3175, Australia. [www.pentair.com.au](http://www.pentair.com.au)

All Pentair trademarks and logos are owned by Pentair, Ltd. All other brand or product names are trademarks or registered marks of their respective owners. Because we are continuously improving our products and services, Pentair reserves the right to change specifications without prior notice.

Pentair is an equal opportunity employer.

ABN 27 004 856 204 © 2012 Pentair, Ltd. All Rights Reserved.

© 2016 Pentair