



 bimotal

# ELEVATE

INSTALLATION INSTRUCTIONS

03	<a href="#">COMPATIBILITY</a>
05	<a href="#">ELEVATE PACKAGE CONTENTS</a>
06	<a href="#">REQUIRED TOOLS</a>
07	<a href="#">NOMENCLATURE</a>
08	<a href="#">ELEVATE MOUNTING BRACKET INSTALLATION</a> FOR 203 MM ROTOR-GEAR ON FRAME WITH PM160 BRAKE CALIPER MOUNT OR 180 MM ROTOR-GEAR OF FRAME WITH PM140 BRAKE CALIPER MOUNT
09	<a href="#">ELEVATE MOUNTING BRACKET INSTALLATION</a> FOR 203 MM ROTOR-GEAR ON FRAME WITH PM180 BRAKE CALIPER MOUNT OR 180 MM ROTOR-GEAR ON FRAME WITH PM160 BRAKE CALIPER MOUNT
11	<a href="#">REAR BRAKE CALIPER INSTALLATION</a>
12	<a href="#">ROTOR-GEAR INSTALLATION (ISO BOLT SYSTEMS)</a>
14	<a href="#">ROTOR-GEAR INSTALLATION (CENTERLOCK SYSTEM)</a>
16	<a href="#">ELEVATE GEAR MESH HEIGHT ADJUSTMENT</a>
19	<a href="#">QUICK-CONNECT SYSTEM ADJUSTMENT</a>
21	<a href="#">REAR WHEEL INSTALLATION</a>
22	<a href="#">GEAR MESH TESTING</a>
24	<a href="#">BATTERY TRAY AND ELECTRICAL CONNECTOR INSTALLATION</a>
29	<a href="#">THROTTLE INSTALLATION</a>
33	<a href="#">FINAL SYSTEM TEST</a>
34	<a href="#">POST-INSTALL</a>

**Before beginning Elevate installation, verify that the customer's bike meets the compatibility criteria below:**

1. Frame has disc brake mounts located above/behind dropout with nothing in the way to collide with drive unit
  - a. Post Mounts can not be larger than 180mm currently (compatibility with 200/203mm Post Mounts will come in the future) - see graphic on next page for reference
2. Hub has ISO / 6-bolt disc brake hub or Centerlock with 6-bolt adapter (we can supply an adapter as needed)
3. There is space for the battery inside the front triangle (or discuss alternate options with the customer if no space available inside the triangle)
4. There are water bottle bosses to mount the battery to frame (or discuss alternate options with customer if not available)
5. The disc brake caliper is a 4-piston hydraulic model for clearance with the Rotor-Gear and the Drive Unit (4 piston brake calipers are longer and shallower vs 2-piston calipers being shorter and taller & cable-activated calipers are much larger and bulkier compared to hydraulic calipers). Bikes with 2-piston hydraulic or cable-activated brake calipers can get calipers or full brake systems swapped to become compatible
  - a. Note that Magura's 4-piston calipers need 0.5mm shim between the caliper and the Elevate Mount to prevent caliper from scraping Rotor-Gear)
6. Bike is in good working condition and safe to ride

## **Suggested actions or remedies:**

1. If the frame does not have compatible disc brake mounts, ask the customer if they have another bike with compatible mounts that they would like to install Elevate on or contact Bimotal to discuss alternative options, including installing on the fork.
2. If the hub has another disc brake interface, contact Bimotal to discuss alternative options.
3. If the bike has broken or damaged parts that make it unsafe to ride, discuss repair options with the customer and ensure that the bike is made safe to ride before continuing Elevate installation.
4. Coordinate replacement of 2-piston brake calipers before beginning Elevate installation.

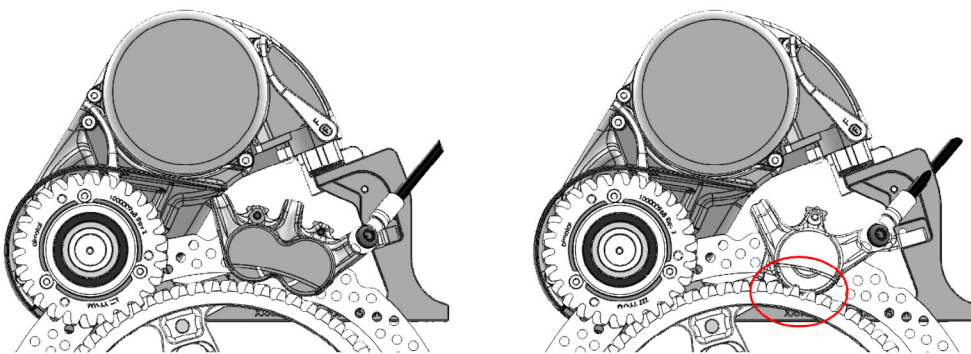

*4-piston brake caliper (left) clears Rotor-Gear teeth while 2-piston caliper (right) does not*

This album contains installed Elevate examples: [Bimotal Elevate Installs](#)

Check the following image for Elevate compatibility with different brake mount locations.

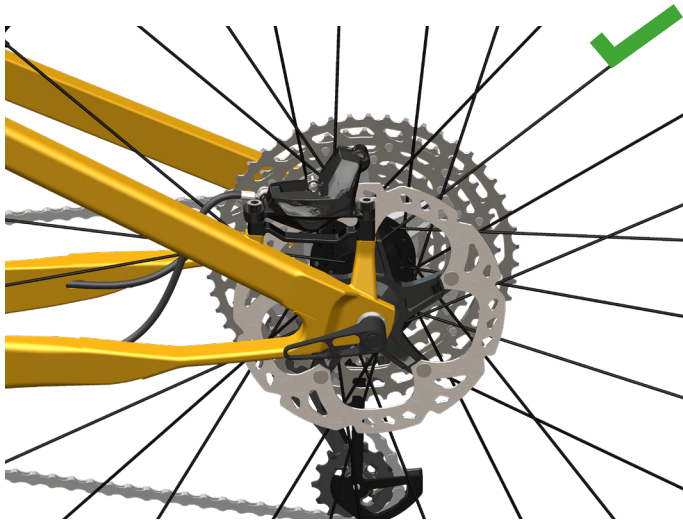

POST MOUNT



ISO MOUNT

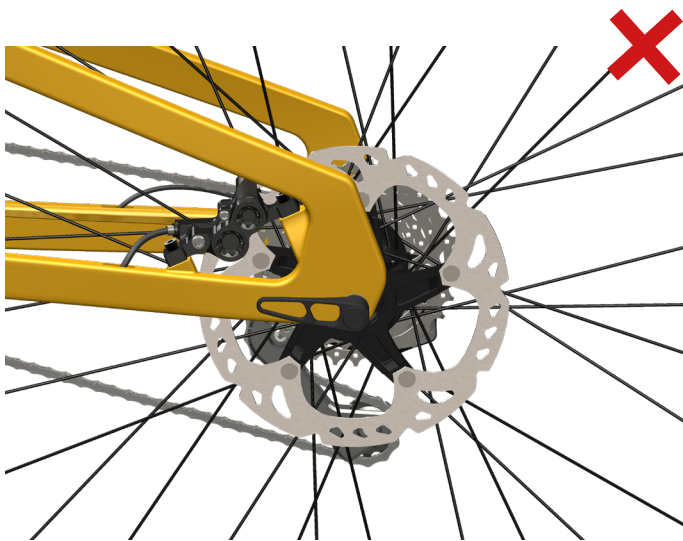

INTERNAL POST MOUNT



INTERNAL FLAT MOUNT

Ensure the brake caliper is a 4-piston hydraulic brake. Some 2-piston calipers may clear the gear but typically they do not. Occasionally a 4-piston caliper may interfere with the gear and require

## The Elevate Package includes the following items:

- (1X) Elevate Drive Unit
- (1X) Mounting bracket
- (1X) Mount adapter
- (2X) Adjustment Nuts
- (2X) Quick-connect studs
- (1X) Rotor-gear (203 mm or 180 mm)
- (1X) 302.4 Wh Battery
- (1X) Battery tray and electrical harness
- (2X) M3 X 8 mm, buttonhead, T10 screws
- (3X) M5 X 10 mm countersunk, HEX screws
- (2X) M5 X 18 mm buttonhead, HEX screws
- (2X) M5 X 16 mm countersunk, T25 screws
- (2X) M6 X 18 mm socket, HEX screws
- (6X) M5 X 10 mm buttonhead, T25 screws
- 0.25 mm and 0.5 mm shims

## **Elevate building essential tools:**

- Measuring Calipers
- Torque wrench that has 0-10 Nm range
- 4 mm HEX bit (torque tool compatible)
- 5 mm HEX bit (torque tool compatible)
- 6 mm HEX Allen key or appropriate tool for rear wheel axle
- T10 TORX bit (torque tool compatible)
- T25 TORX bit (torque tool compatible)
- 16 mm socket
- Loctite® Threadlocker Red 271™ or similar equivalent
- Loctite® Threadlocker Blue 242® or similar equivalent

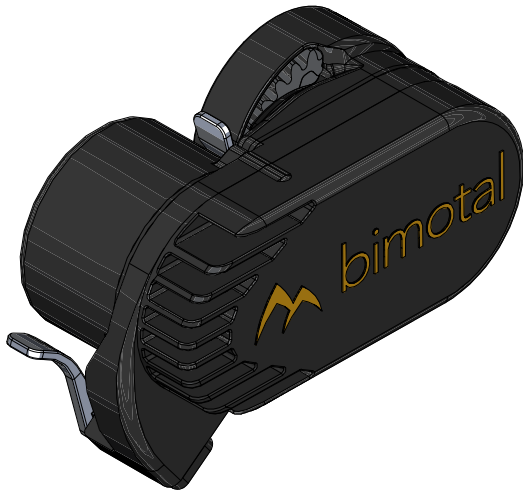

ELEVATE DRIVE UNIT (LEFT SIDE VIEW)

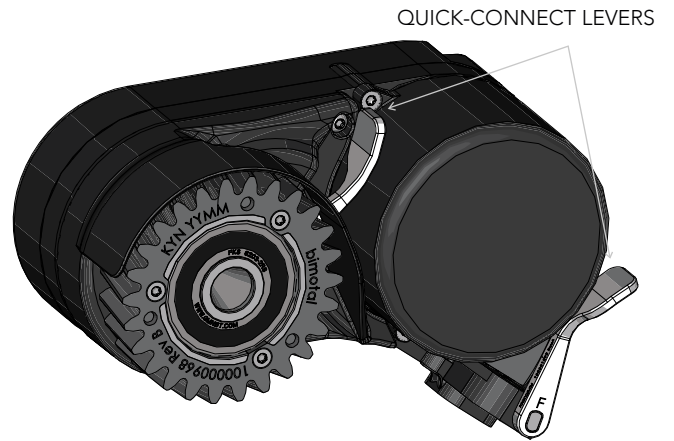

ELEVATE DRIVE UNIT (RIGHT SIDE) VIEW)

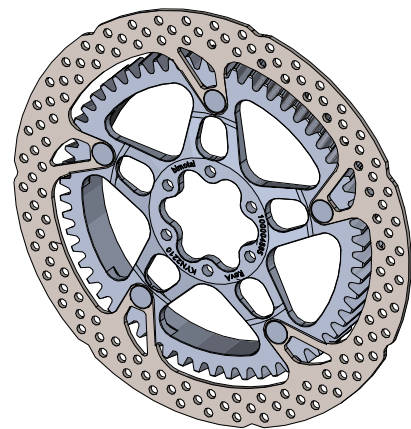
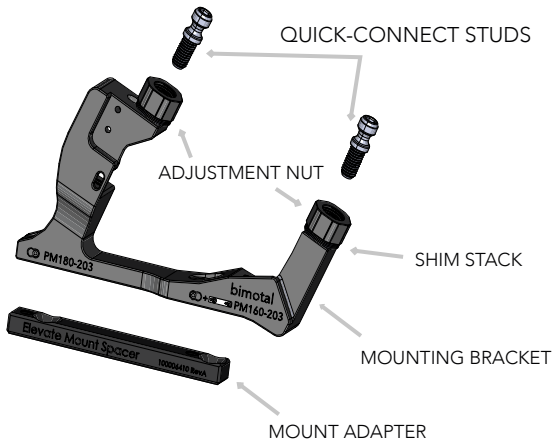

ELEVATE ROTOR-GEAR

# ELEVATE MOUNTING BRACKET INSTALLATION

FOR 203 MM ROTOR-GEAR ON FRAME WITH PM160 BRAKE CALIPER MOUNT OR 180 MM ROTOR-GEAR ON FRAME WITH PM140 BRAKE CALIPER MOUNT

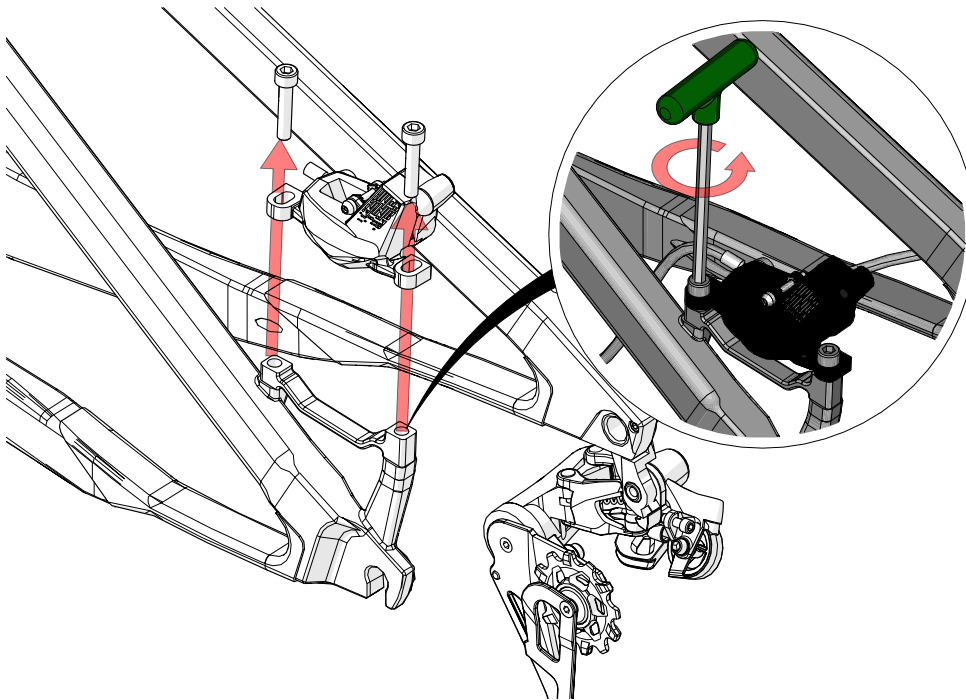

1) Remove the rear wheel from the frame. Remove the rear brake caliper and fold it out of the way. If the bike included an adapter between the frame and the caliper, save the adapter and return it to customer.

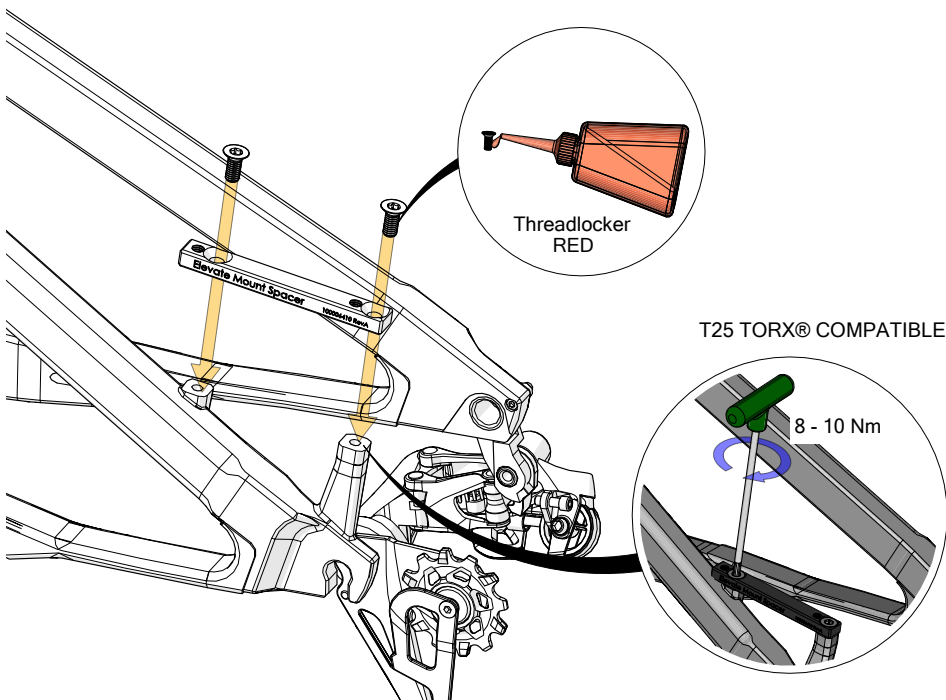

2) Align the countersunk holes of the Mounting bracket Spacer with the threaded holes on the brake mount. Add a drip of Loctite® Threadlocker Red 271™ or similar equivalent to (2X) M5X16mm countersunk screws and tighten them to the specified torque to secure the adapter.

Note: use manufacturer's spec. if lower than Bimotal's recommended 8-10Nm.



# ELEVATE MOUNTING BRACKET INSTALLATION

FOR 203 MM ROTOR-GEAR ON FRAME WITH PM160 BRAKE CALIPER MOUNT OR 180 MM ROTOR-GEAR ON FRAME WITH PM140 BRAKE CALIPER MOUNT

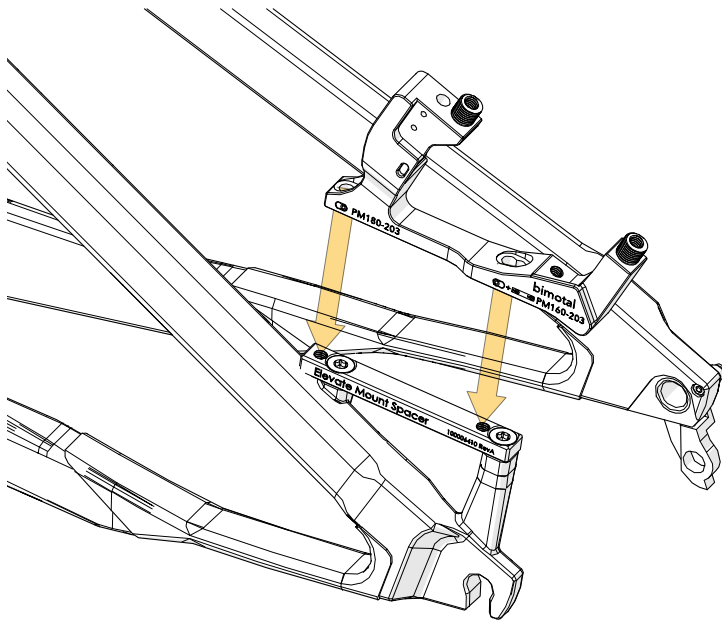

3) Align the Mounting bracket to the Mounting bracket Adapter as indicated in the picture. Add a drip of Loctite® Threadlocker Red 271TM or similar equivalent to (2X) M6 X 18 mm socket screws ad tighten to the torque spec.

The Mounting Bracket includes two holes per bolt. Use the rear hole as indicated in the correct vs erroneous picture. Ensure that the Mounting bracket bolts don't protrude past the bottom of the Mounting bracket Spacer to prevent damaging the frame.

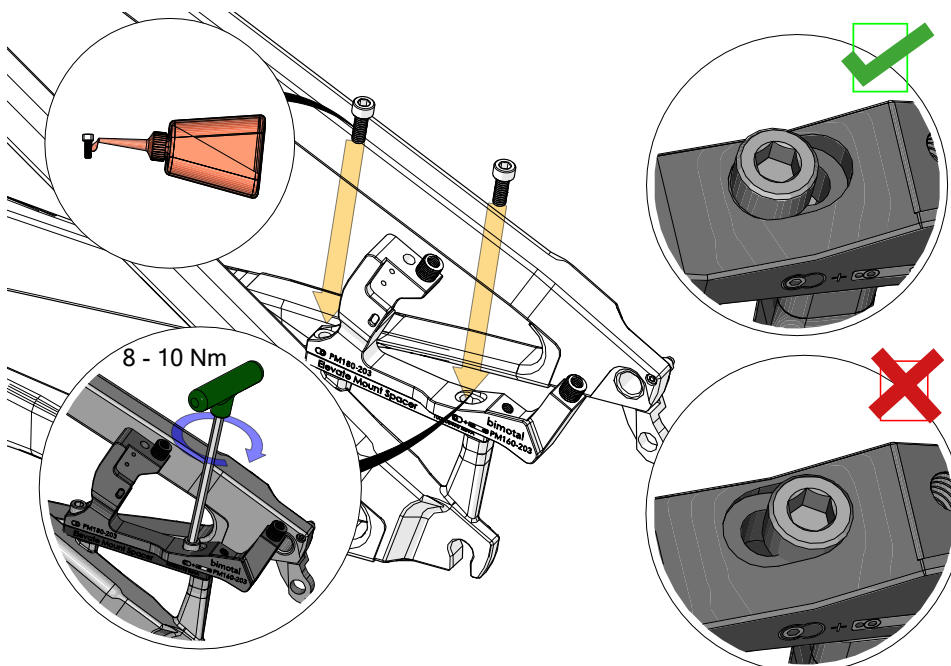

# ELEVATE MOUNTING BRACKET INSTALLATION

FOR 203 MM ROTOR-GEAR ON FRAME WITH PM180 BRAKE CALIPER MOUNT OR 180 MM ROTOR-GEAR ON FRAME WITH PM160 BRAKE CALIPER MOUNT

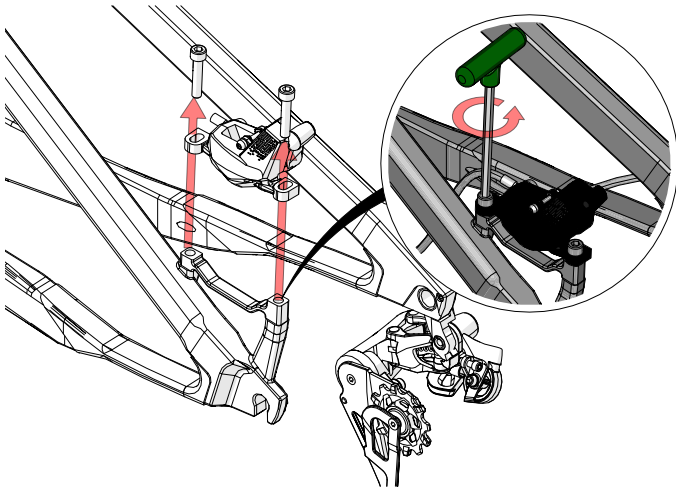

1) Remove the rear wheel from the frame. Remove the rear brake caliper and fold it out of the way. If the bike included an adapter between the frame and the caliper, save the adapter and return it to customer.

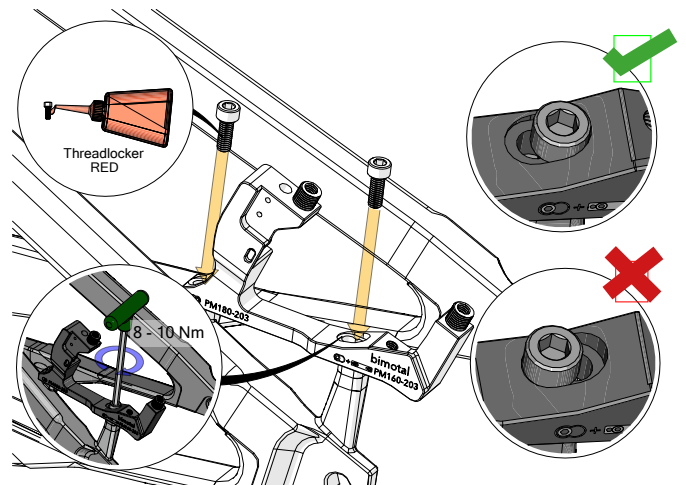
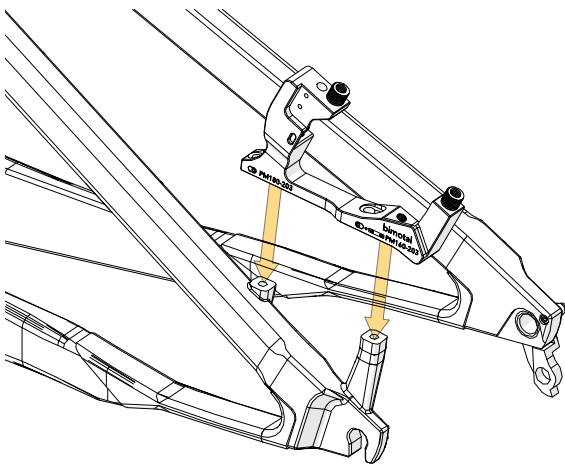

2) Align the Mounting bracket with the threaded holes on the caliper mount of the frame. Apply Loctite® Threadlocker Red 271™ or similar equivalent to (2X) M6 X 18 mm socket screws and tighten to the torque spec and tighten to the specified torque. The Mounting Bracket includes two bolt positions per mount point. Use the front hole as indicated in the correct vs erroneous picture above on the right.

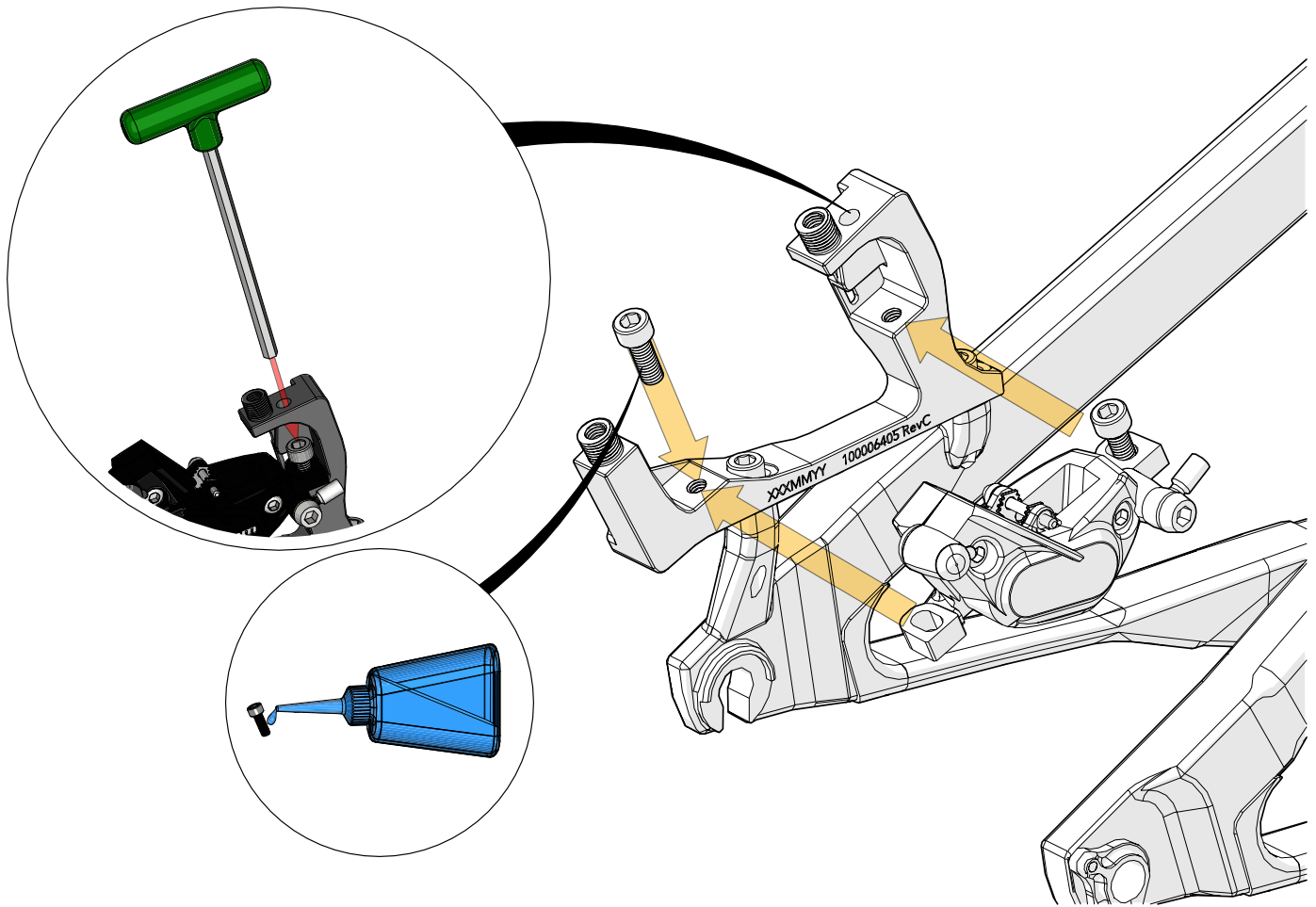

1) Loosely place the front bolt into the caliper and slide the brake caliper in position according to brake manufacturer instructions. Add Loctite® Threadlocker Blue 242® or similar equivalent to the threads of the caliper bolts and tighten to 8-10 Nm or the torque spec specified by the brake caliper manufacturer, if lower than 8 Nm. For the front bolt, use the hole on the Mounting bracket to pass the wrench through to tighten the bolt.

Note: If previously the brake caliper was secured with bolts passing through the caliper and an adapter, then alternate brake caliper bolts will be needed to install the brake caliper to the Elevate Mounting Bracket.

To accommodate brake calipers equipped with banjo fittings, you may have to reposition the hose to clear the Elevate Mount.

# ROTOR-GEAR INSTALLATION (ISO BOLT SYSTEMS)

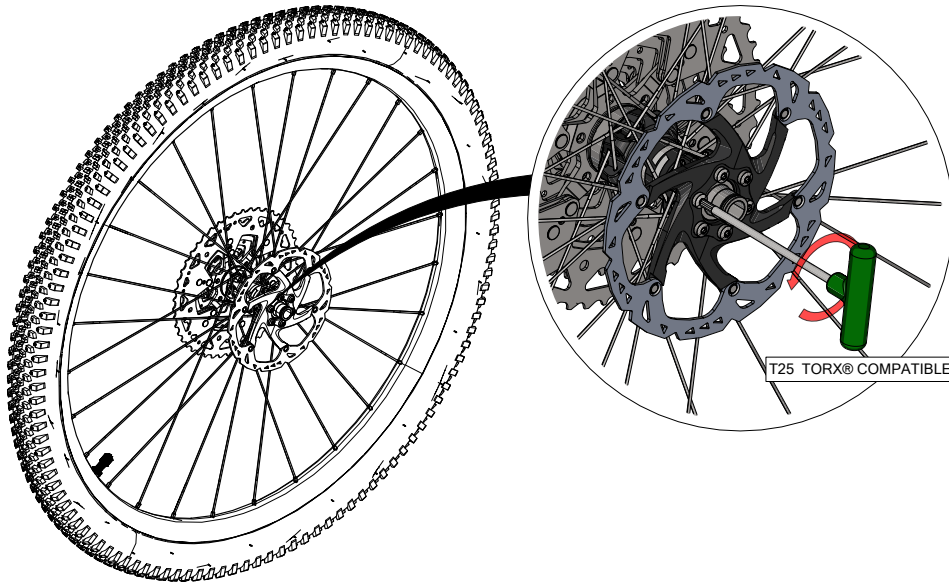

1) Remove the rear wheel from the bike frame. Use the T25 TORX-compatible hand wrench to remove the six ISO bolts securing the brake rotor to the wheel hub. Remove the brake rotor from the wheel hub.

Save the native brake rotor to return to customer.

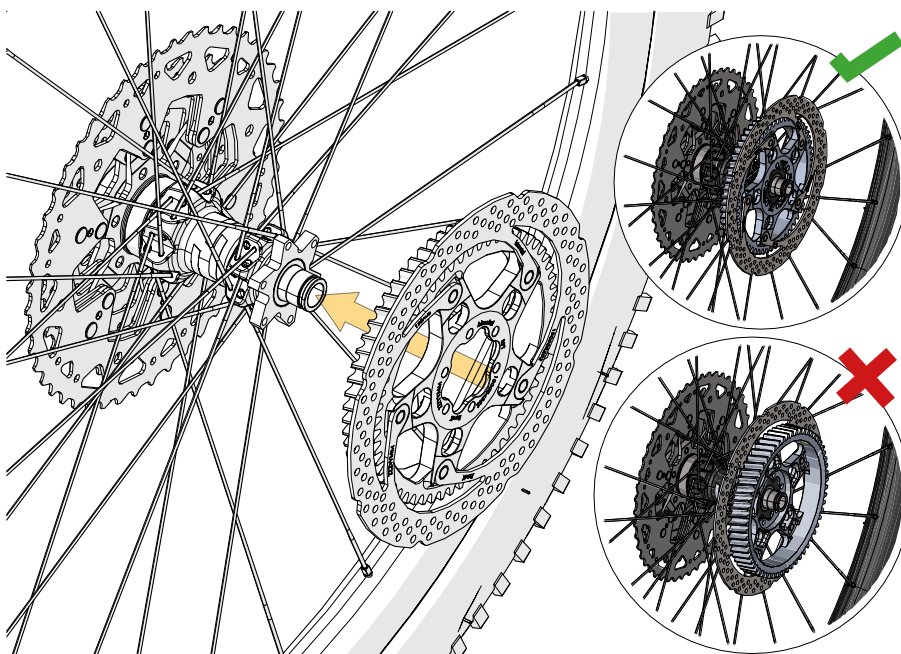

2) Fit the Rotor-Gear with the gear facing the wheel hub.

# ROTOR-GEAR INSTALLATION (ISO BOLT SYSTEMS)

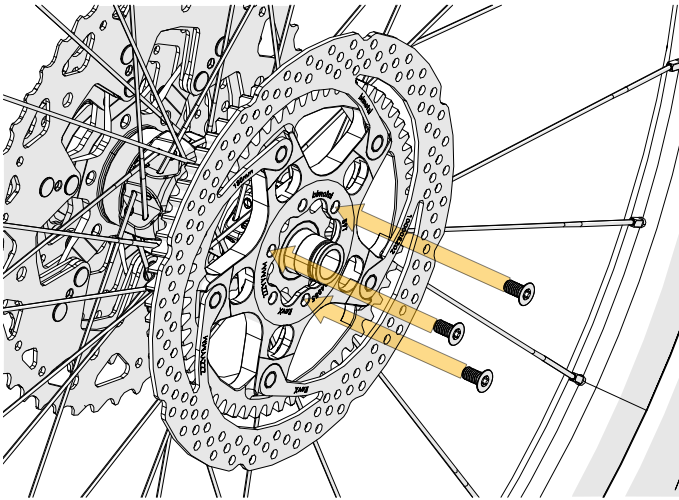

3) Install (3X) M5 X 16 mm countersunk screws into every other hole on the hub and tighten until snug. This will help ensure that the Rotor-Gear is concentric with the hub for proper gear meshing.

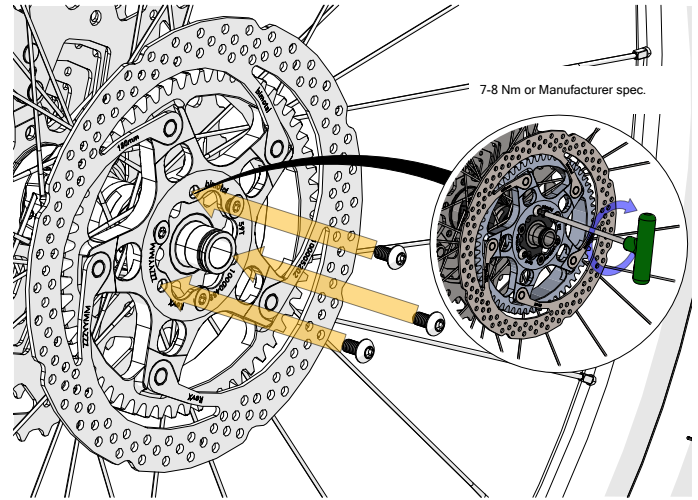

4) Apply Loctite® Threadlocker Blue 242® or equivalent to (3X) M5 X 10 mm buttonhead screws and install them in the three open holes of the Rotor-Gear to 6-8 Nm or the torque specified by the wheel hub manufacturer, if lower.

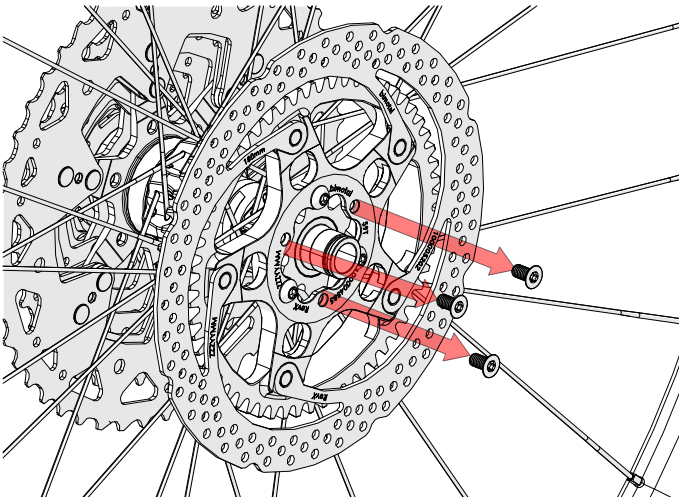

5) Remove the three countersunk screws.

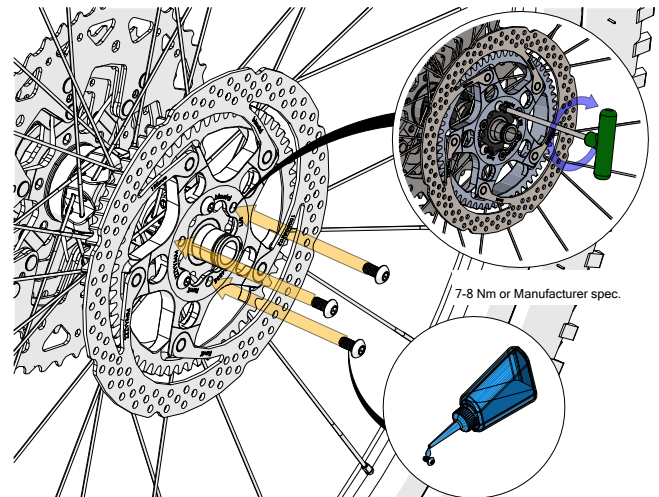

6) Apply Loctite® Threadlocker Blue 242® or equivalent to the (3X) M5 X 10 mm buttonhead screws and tighten them to 6-8 Nm or the torque specified by the wheel hub manufacturer

# ROTOR-GEAR INSTALLATION (CENTERLOCK SYSTEMS)

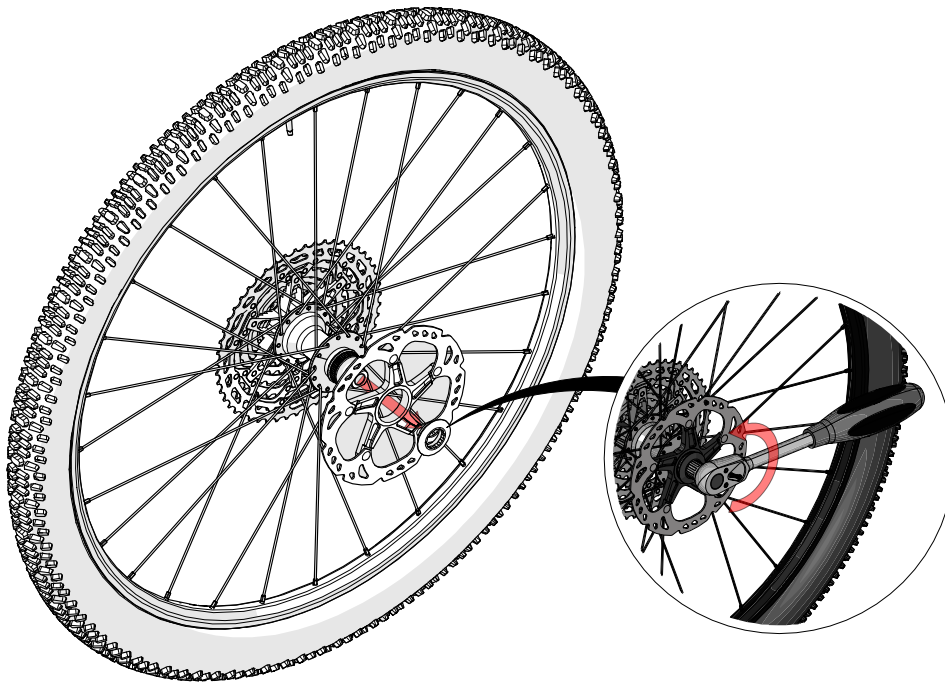

1) Remove the rear wheel from the bike frame. Loosen the lock ring and remove the brake rotor from the wheel hub. For precise instructions and required tools for this operation, consult the manufacturer's manual.

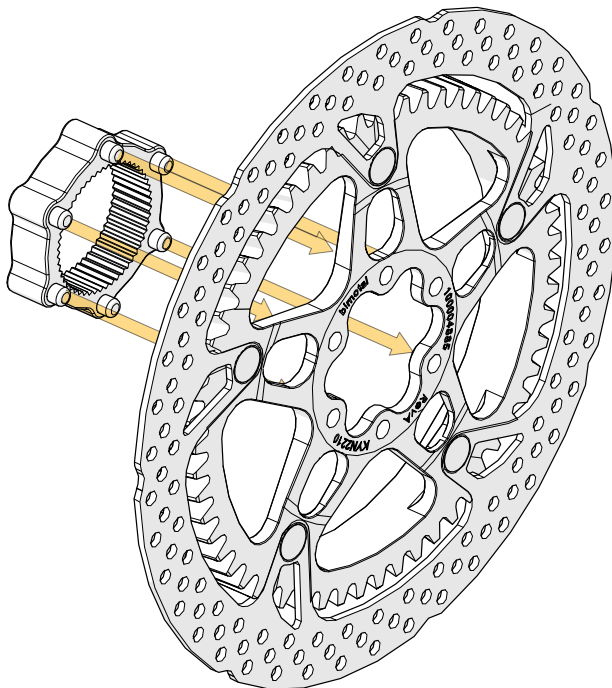

2) Fit the ISO to Centerlock adapter in the Rotor-Gear from the side indicated in the illustration.

Note: The illustration only shows a pinned adapter. Other adapters with threaded holes are also compatible with Elevate.

# ROTOR-GEAR INSTALLATION (CENTERLOCK SYSTEMS)

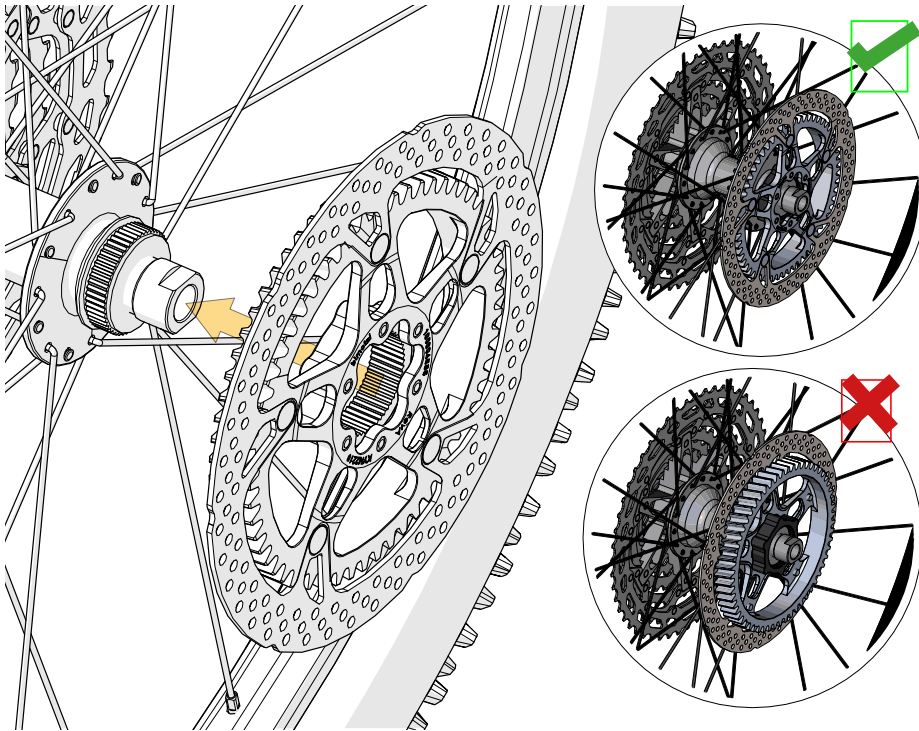

3) Fit the Rotor-Gear with the gear facing the wheel hub.

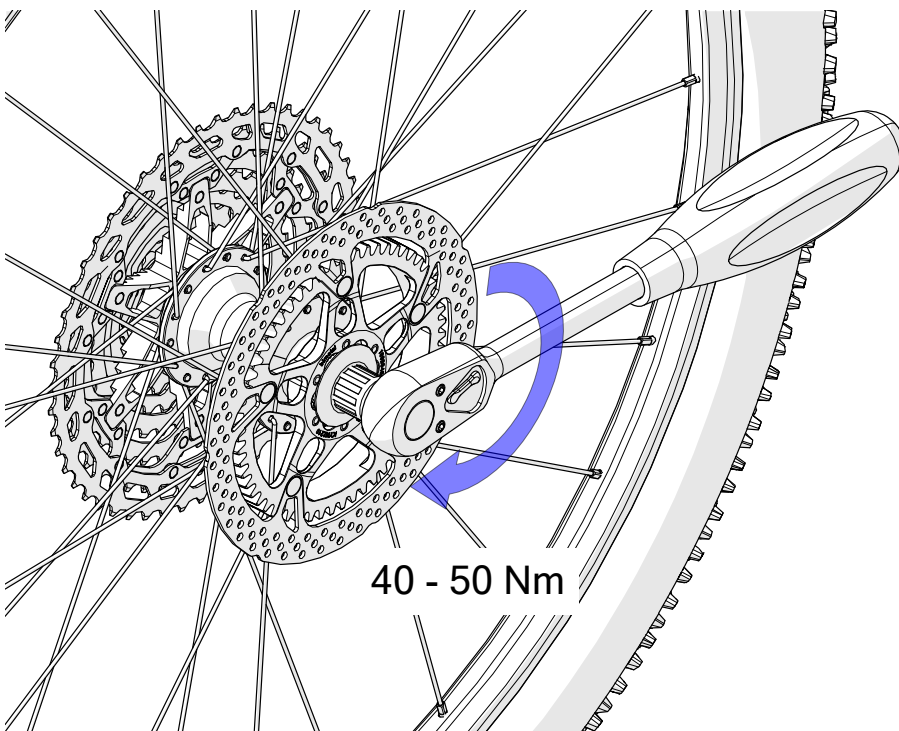

4) Tighten the Centerlock nut to torque specified by manufacturer.

# ELEVATE GEAR MESH HEIGHT ADJUSTMENT

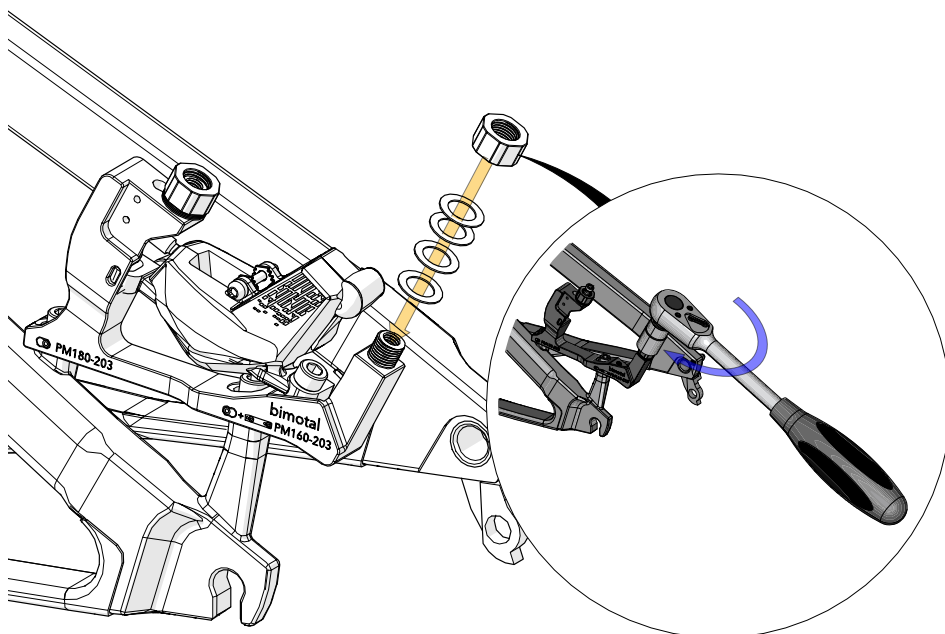

1) Insert a 2.0 mm shim stack made up of (4X) 0.5mm shims onto both threaded tubes on the Mounting Bracket and snug the Adjustment Nut using a ratchet wrench with a 16 mm socket. Snug the Adjustment Nut until the lower surface of the nut touches the shim stack.

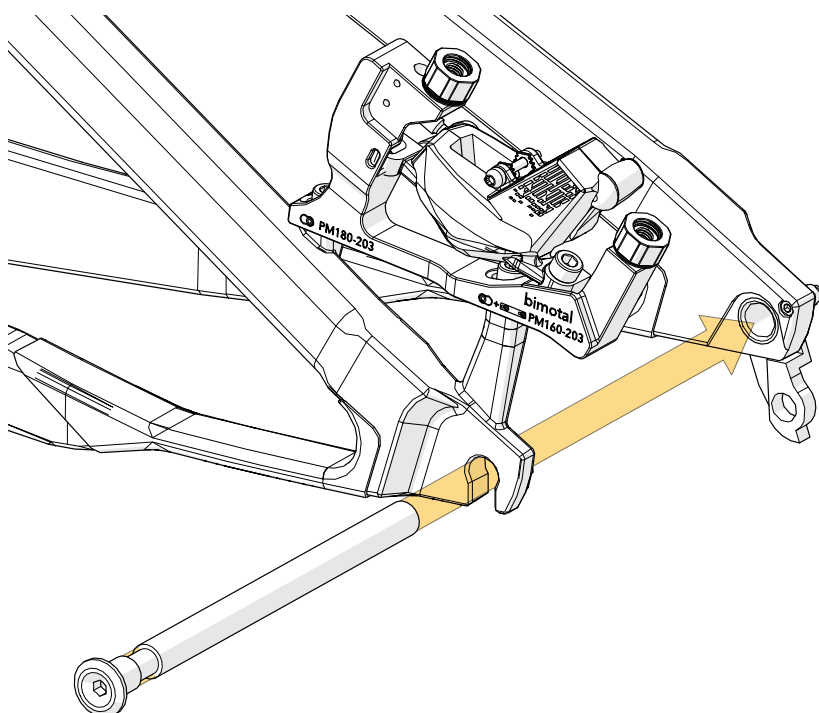

2) Install the rear wheel axle.



# GEAR MESH HEIGHT ADJUSTMENT

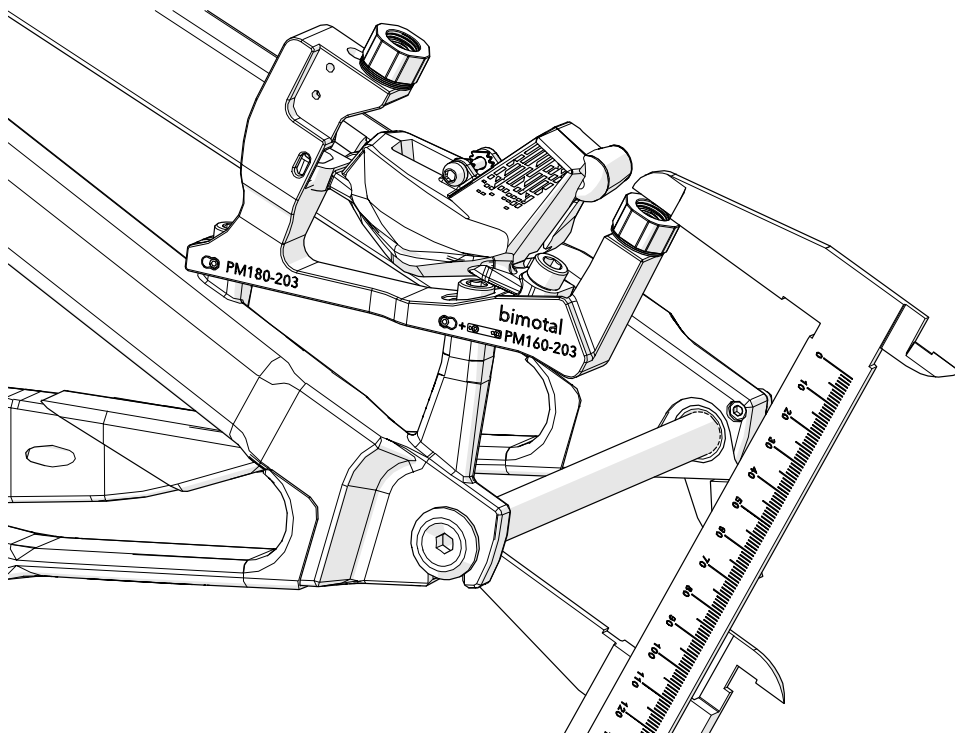

3) Use a caliper to measure the distance from the upper surface of the rear Adjustment Nut and the bottom of the axle. Measure the axle diameter as well.

Caliper Measurement - 1/2 * Axle Diameter				
180mm Shim Chart		203mm Shim Chart		
Min	Max	Min	Max	Adjustment
100.10	or more	100.10	or more	Mount too low
100.11	100.35	100.11	100.35	Add 4x 0.5mm Shims + 0x 0.25mm shims
100.36	100.60	100.36	100.60	Add 3x 0.5mm Shims + 1x 0.25mm shims
100.61	100.85	100.61	100.85	Add 3x 0.5mm Shims + 0x 0.25mm shims
100.86	101.10	100.86	101.10	Add 2x 0.5mm Shims + 1x 0.25mm shims
101.11	101.35	101.11	101.35	Add 2x 0.5mm Shims + 0x 0.25mm shims
101.36	101.60	101.36	101.60	Add 1x 0.5mm Shims + 1x 0.25mm shims
101.61	101.85	101.61	101.85	Add 1x 0.5mm Shims + 0x 0.25mm shims
101.86	102.10	101.86	102.10	Add 0x 0.5mm Shims + 1x 0.25mm shims
102.11	102.35	102.11	102.35	Good to go
102.35	102.59	102.35	102.59	Good to go
102.60	102.84	102.60	102.84	Subtract 0x 0.5mm Shims + 1x 0.25mm shims
102.85	103.09	102.85	103.09	Subtract 1x 0.5mm Shims + 0x 0.25mm shims
103.10	103.34	103.10	103.34	Subtract 1x 0.5mm Shims + 1x 0.25mm shims
103.35	103.59	103.35	103.59	Subtract 2x 0.5mm Shims + 0x 0.25mm shims
103.60	103.84	103.60	103.84	Subtract 2x 0.5mm Shims + 1x 0.25mm shims
103.85	104.09	103.85	104.09	Subtract 3x 0.5mm Shims + 0x 0.25mm shims
104.10	104.34	104.10	104.34	Subtract 3x 0.5mm Shims + 1x 0.25mm shims
104.35	104.59	104.35	104.59	Subtract 4x 0.5mm Shims + 0x 0.25mm shims
104.60	or more	104.60	or more	Mount too high

4) Use the measurements from Step 3) and follow the adjustment indications from the table (left).

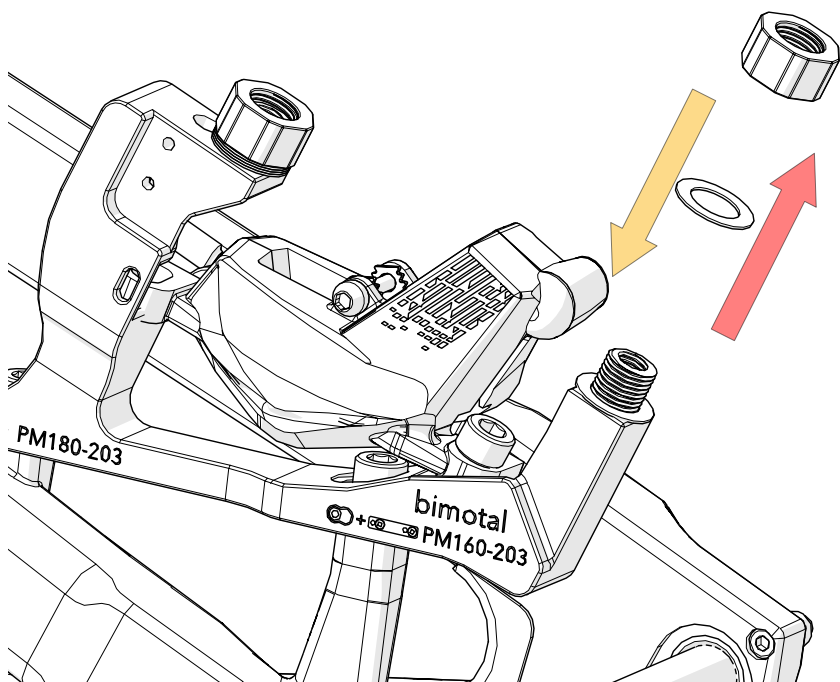

5) Add or subtract shims as indicated by the table above by removing the Adjustment Nut, adding or removing 0.25 mm and 0.5 mm thick shims. Always add/remove the same stack length of shims on both sides of the Mounting Bracket. Put Adjustment Nuts back in place and tighten to 2 Nm.

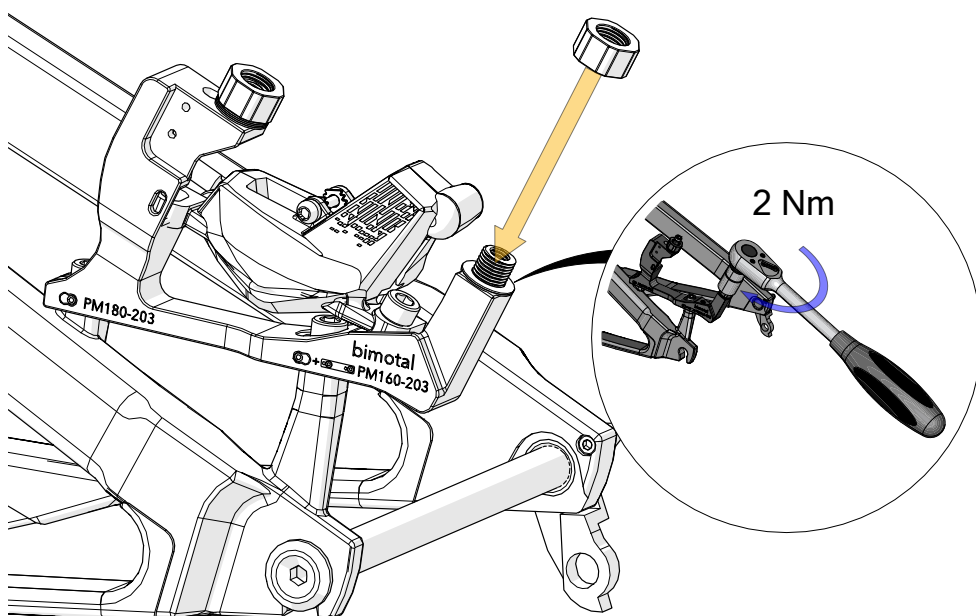

## WARNING:

The height of the shim stack must be between 0 and 4mm.

6) Repeat Steps 3) and 4) to verify that the table output indicates no adjustment is needed.

7) Remove the rear wheel axle from the bike frame.

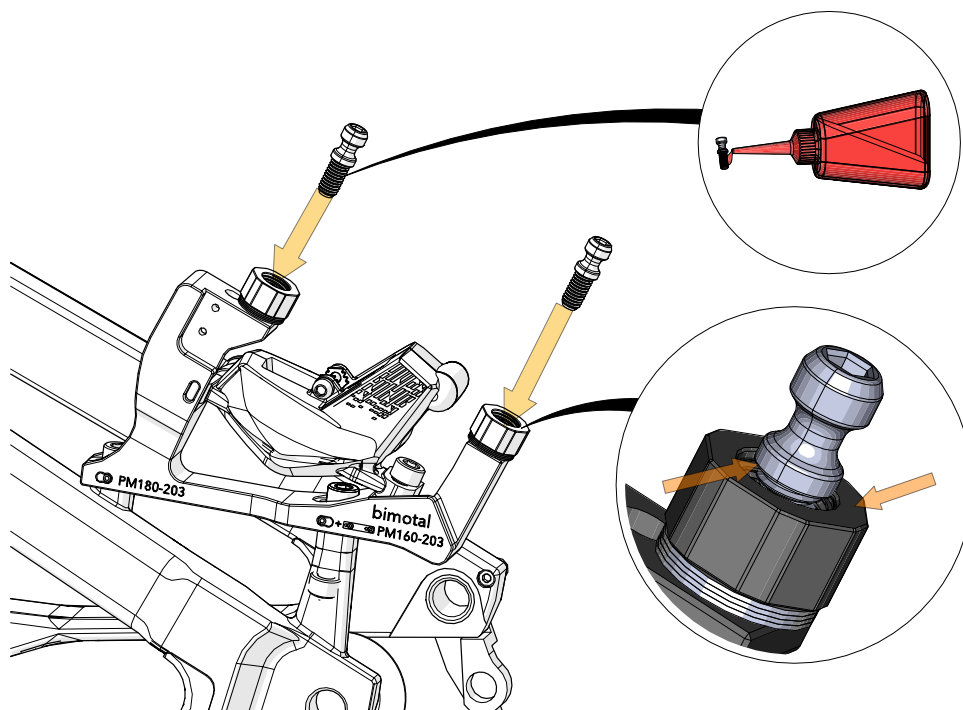

1) Add Loctite® Threadlocker Red 271™ or similar equivalent to the Quick-Connect Stud threads and thread them into the Mounting Bracket until the start of the threads is approximately flush with the top surface of the Adjustment Nuts.

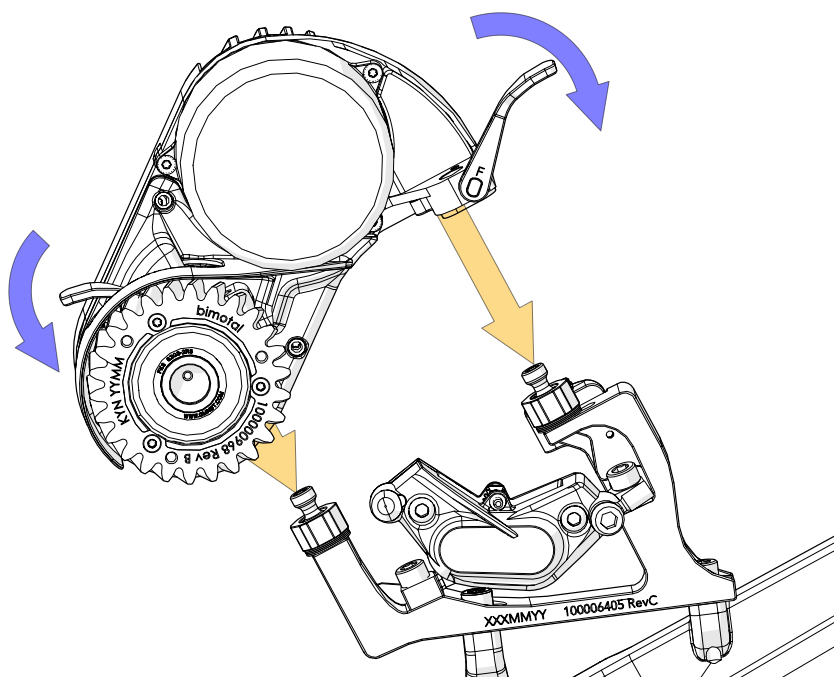

2) Place the Elevate Drive Unit on the Quick-Connect Studs.

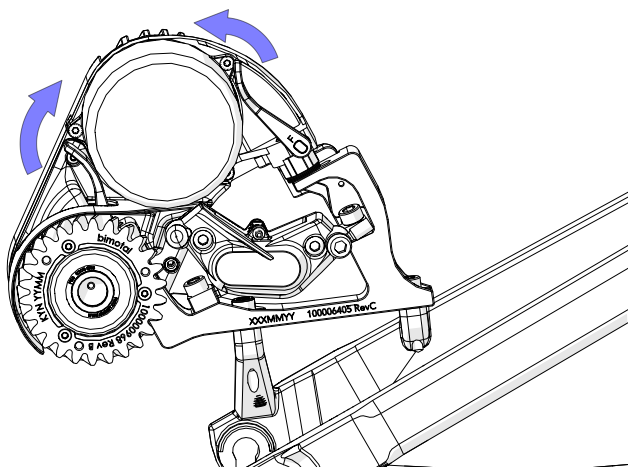

3) Close the Quick-Connect Levers.

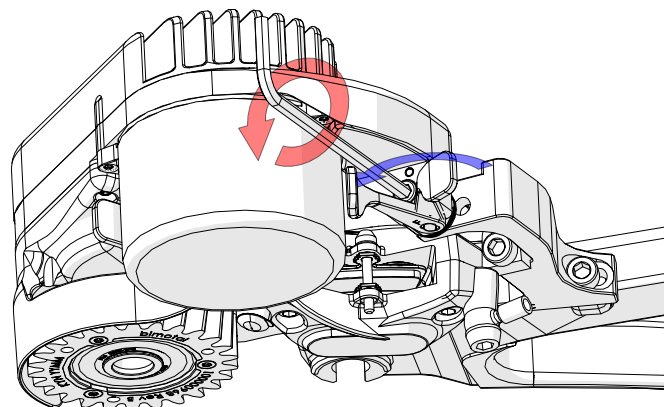

4) If the levers offer high resistance when closing, unthread the Quick-Connect Studs using a 4mm Allen key until the levers can close easily.

5) With the levers closed, tighten the studs using a 4mm hand wrench until there is a firm resistance.

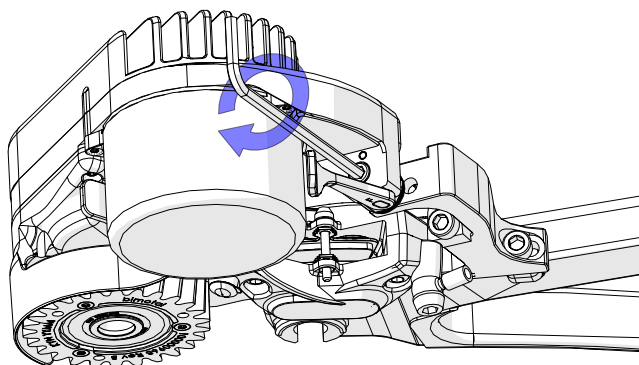

6) Open the levers and close them again.

If the levers are loose and the Elevate Drive Unit is not rigidly attached to the Mounting bracket, turn the studs 1/32 of a complete rotation to the right to tighten the assembly (righty-tighty) and close the levers again.

If the levers are difficult to close, turn the studs 1/32 of a complete rotation to the left (lefty-loosey) and close the levers. Repeat this iterative process until you obtain a rigid attachment of the Drive Unit with a

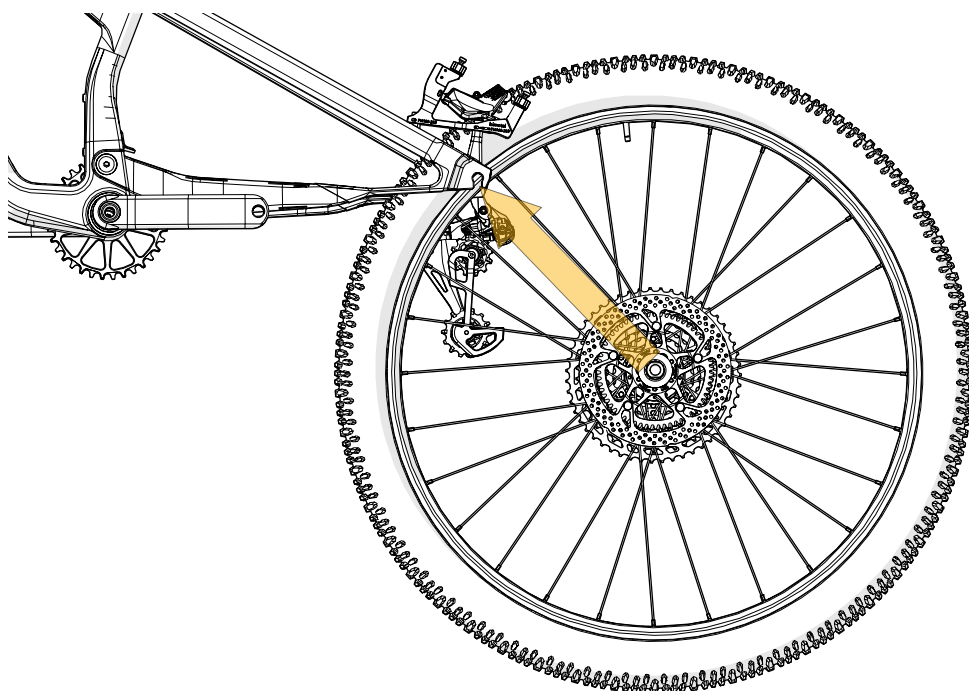

1) Install the rear wheel into the frame.

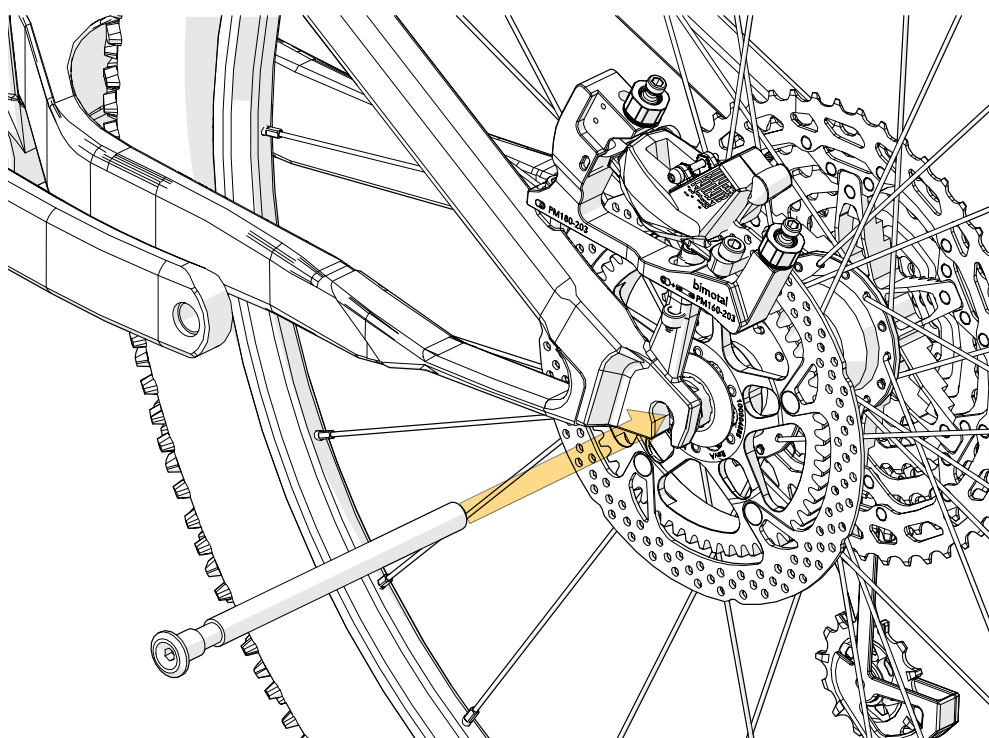

2) Install the rear wheel axle.

Note: At this point you may want to check disc brake rotor to caliper alignment. Loosen the brake caliper bolts slightly, apply the brake lever, and tighten front and rear caliper bolts in an alternating fashion to avoid twisting the caliper. Once both bolts are snug, torque to manufacturer's spec.

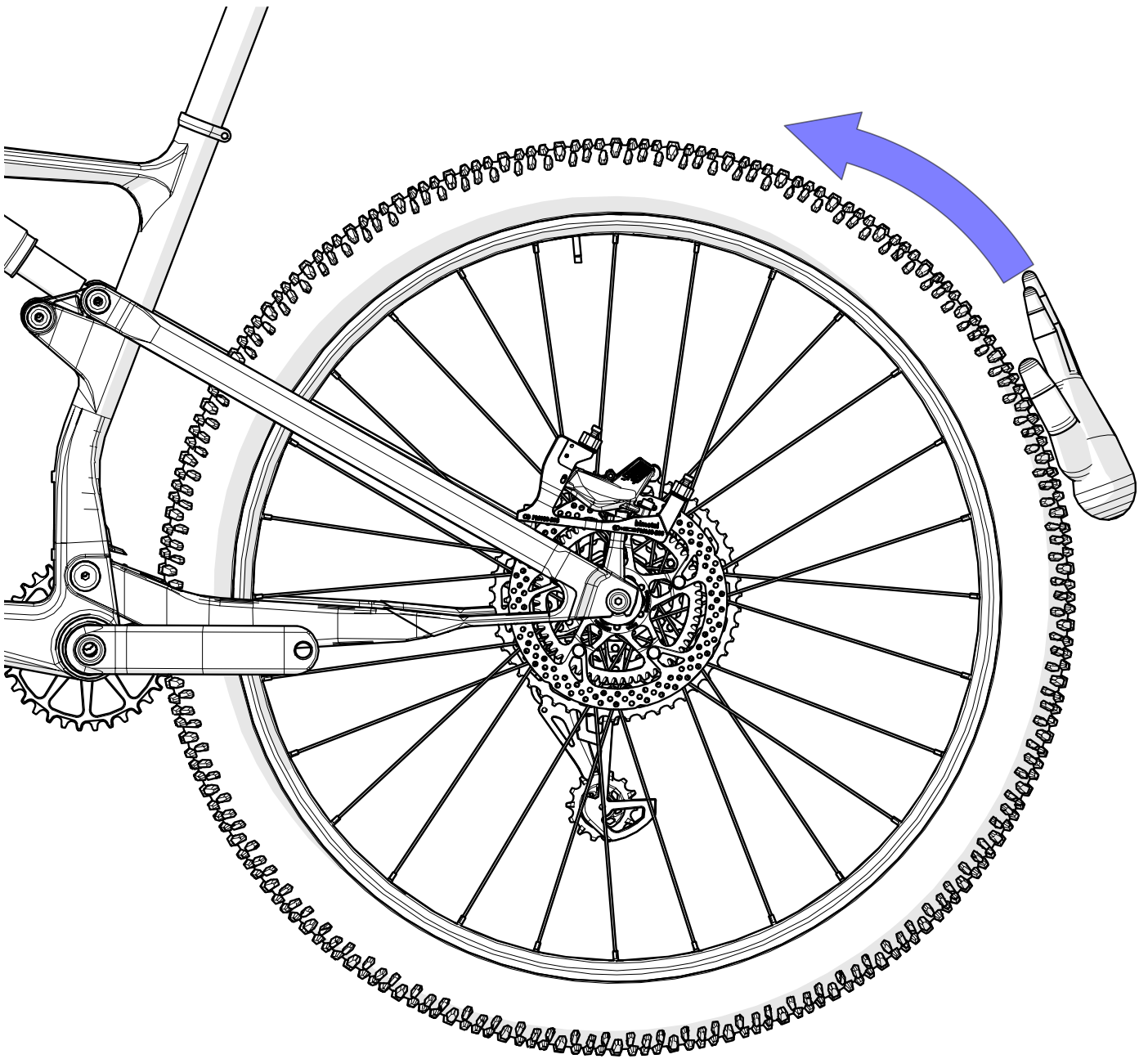

1) Spin the wheel by hand. Look and listen for any signs of rubbing. The wheel should spin smoothly. If rubbing occurs, check for Rotor-Gear contacting the underside of the brake caliper; or, readjust brake caliper position to be centered with the brake pads.

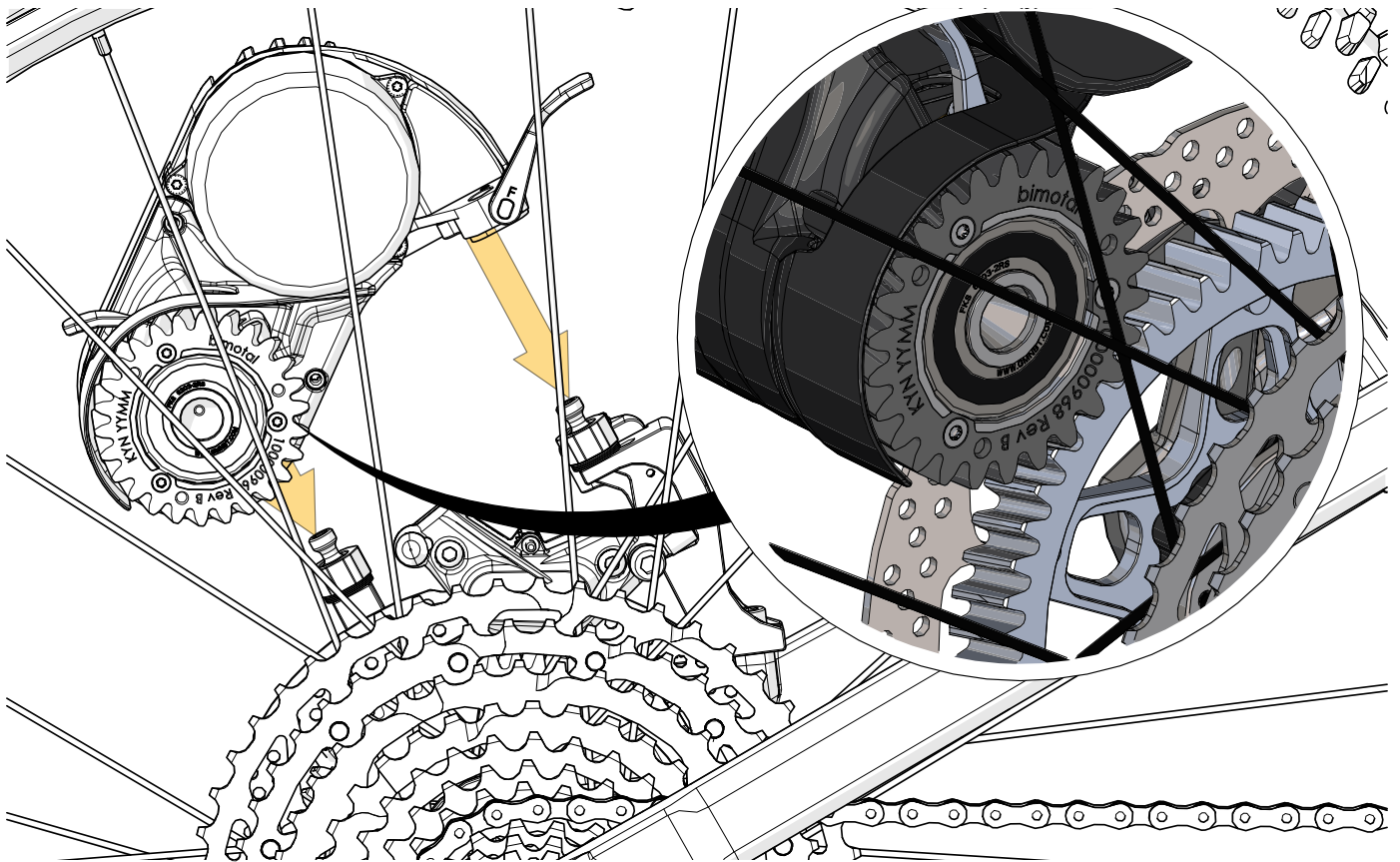

2) Install the Elevate Drive Unit onto the Mounting Bracket and close the Quick-Connect Levers after aligning the gears. Spin the wheel to align the Rotor-Gear teeth with the external gear on the Drive Unit. Once the mesh is engaged, the Elevate Drive Unit should easily drop into position.

3) Rotate the rear wheel forward by hand. Look and listen for any signs of rubbing. The wheel should spin forward smoothly, just as without the Elevate Drive Unit.

a.) If the wheel spins forward slower or there is noise, vibration or drag, then the Rotor-Gear mesh is not set properly. Rotate the wheel both with and without the drive unit in place to compare and confirm the symptom.

b.) If there is constant noise/vibration/drag, then the Rotor-Gear mesh is probably too tight. Repeat GEAR MESH HEIGHT ADJUSTMENT.

c.) If there are tight and loose spots, then the Rotor-Gear is probably not centered well on the hub. Remove the wheel and repeat ROTOR-GEAR INSTALLATION.

Note: It is normal to feel Friction and hear internal gear meshing noise when the wheel is rotated backwards.

If the symptom is not (a), (b), or (c), contact Bimotal support for further assistance diagnosing: [service@](mailto:service@bimotal.com)

# BATTERY TRAY AND ELECTRICAL CONNECTOR INSTALLATION

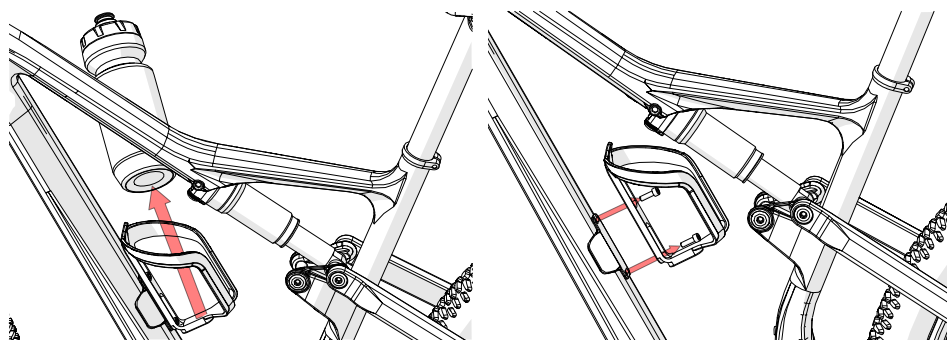

1) Take out the bolts and bottle cage from the downtube.

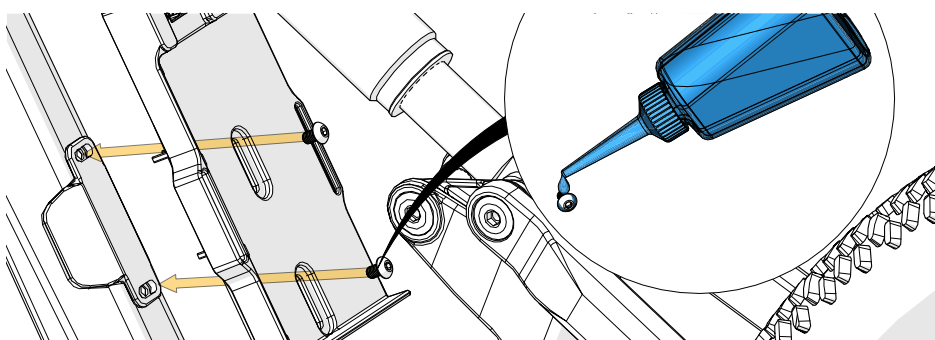

2) Put in the Battery Tray, apply Loctite® Threadlocker Blue 242® or a similar product to the provided (2X) M5 X 18 mm buttonhead screw, and loosely tighten them so the tray can slide along the slot.

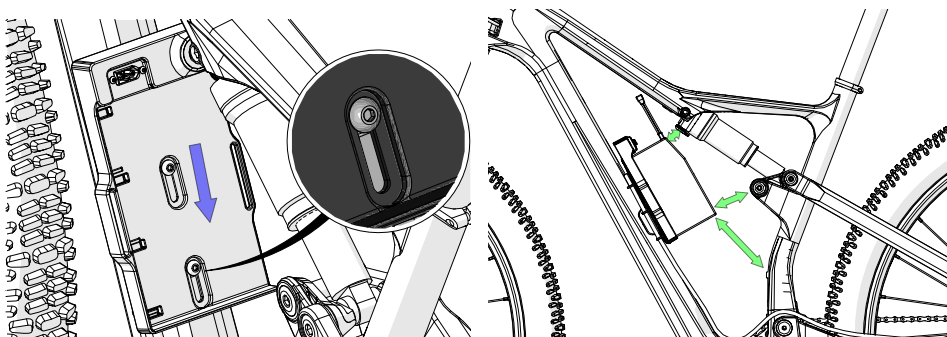

3) Position Battery Tray in the lowest position that allows the battery to clear the frame, rear shock, and suspension linkages. Temporarily snug the Battery Tray screws which will be tightened shortly.

Once the Battery is fully inserted in the tray, check the clearance with the rear shock. Deflate the rear shock and check the clearance across the full range of rear suspension travel. Refer to the shock / suspension manual to safely release air or shock pressure. Similarly, defer to the shock / suspension manual when re-setting the shock appropriately for the user. Remove the battery from the tray once the adjustment is done.



# BATTERY TRAY AND ELECTRICAL CONNECTOR INSTALLATION

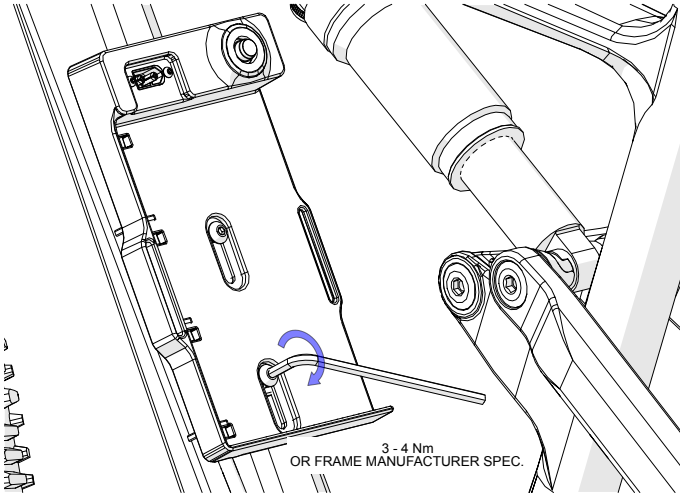

4) Once the Battery Tray height is adjusted to ensure clearance with the frame and moving components, fully secure the Battery Tray in place by tightening the screws. For the torque specification, follow the frame Manufacturers recommendation.

Note: double check that you used blue loctite!

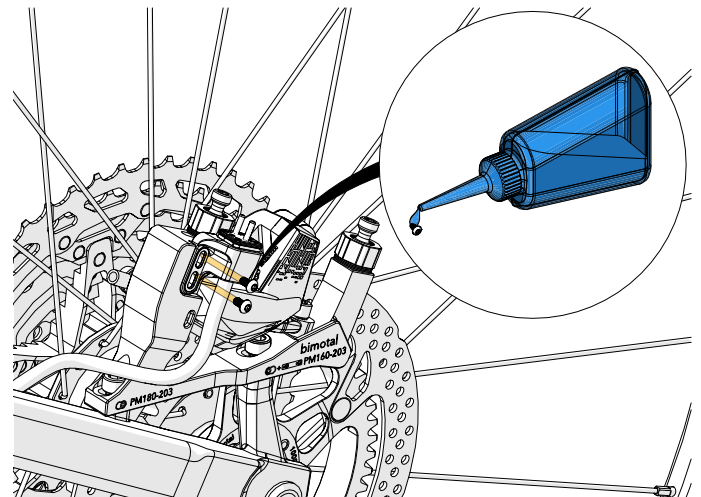
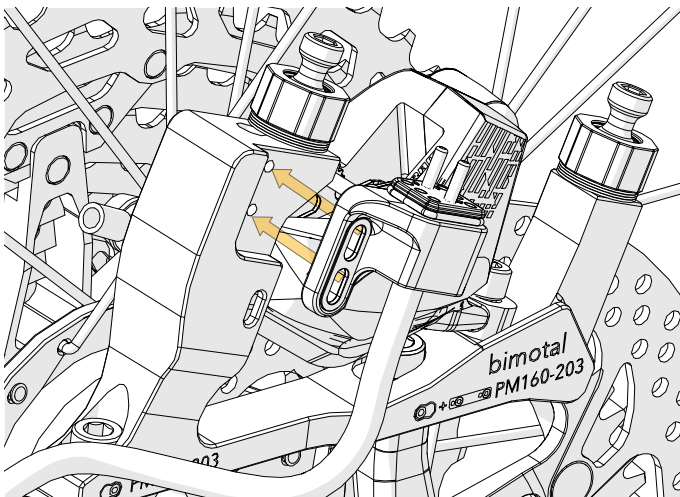

5) The Battery Tray includes a long vehicle harness ending on a plastic electrical connector. Guide the harness behind the seat stay and align the metallic washer of the connector with the threaded holes in the Bracket Mount as indicated in the picture. Apply Loctite® Threadlocker Blue 242® or similar equivalent to the threads of (2X) M3 X 10 mm button head screws. Loosely tighten them to the Mounting Bracket, clamping the electrical connector while still allowing it to move for vertical adjustment. You will torque these to spec in the next step once the connector height is set.

# BATTERY TRAY AND ELECTRICAL CONNECTOR INSTALLATION

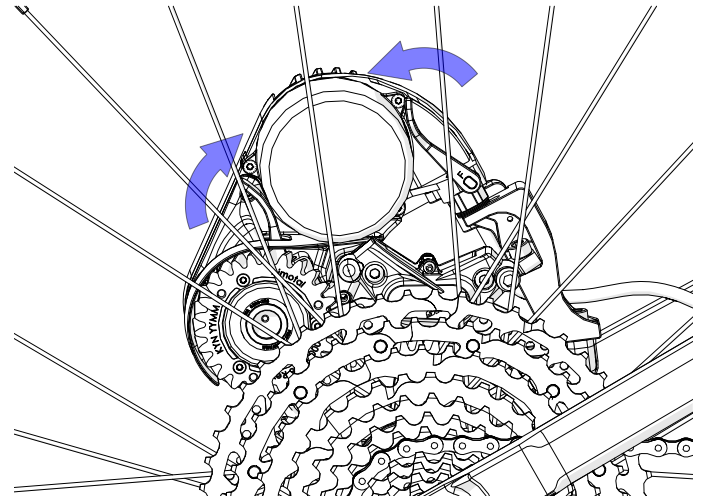
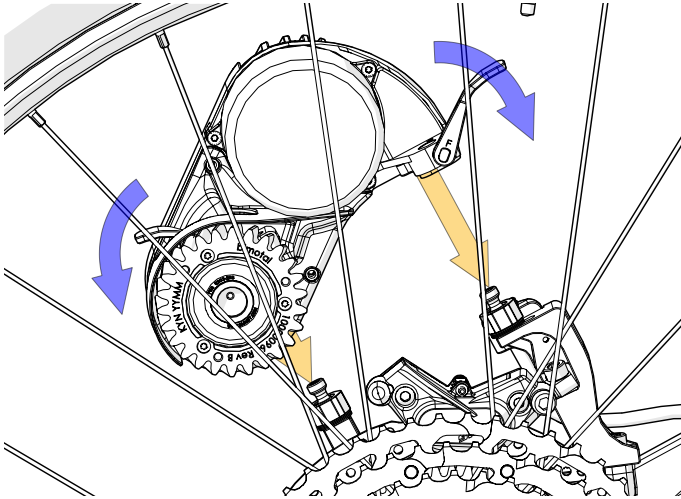

6) Install the Elevate Drive Unit on the Mounting bracket and close the Quick-connect Levers after aligning the gears.

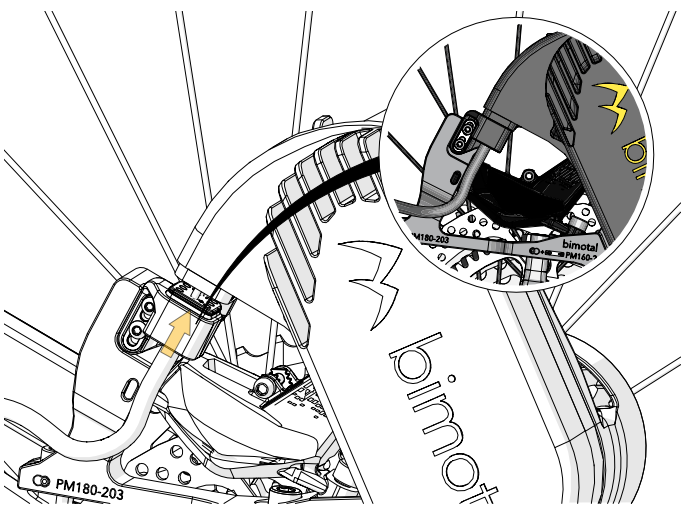

7) Slide the connector up as far as it can go into the Drive Unit.

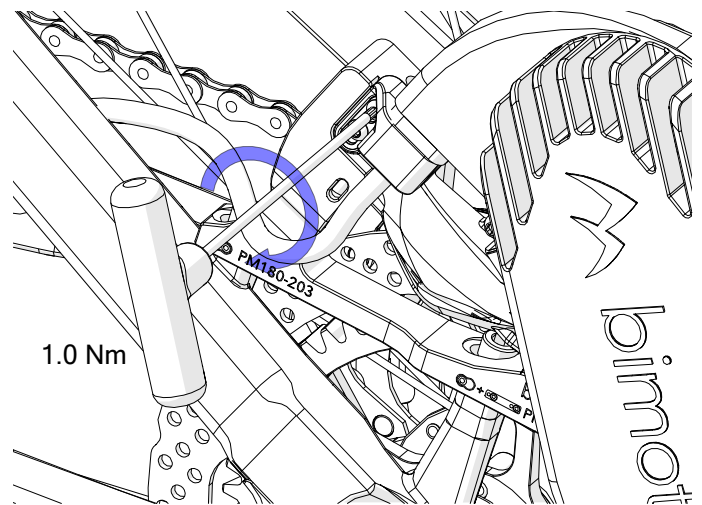

8) Hold the connector in position and tighten the M3 X10 mm buttonhead screws to 1.0 Nm.

# BATTERY TRAY AND ELECTRICAL CONNECTOR INSTALLATION

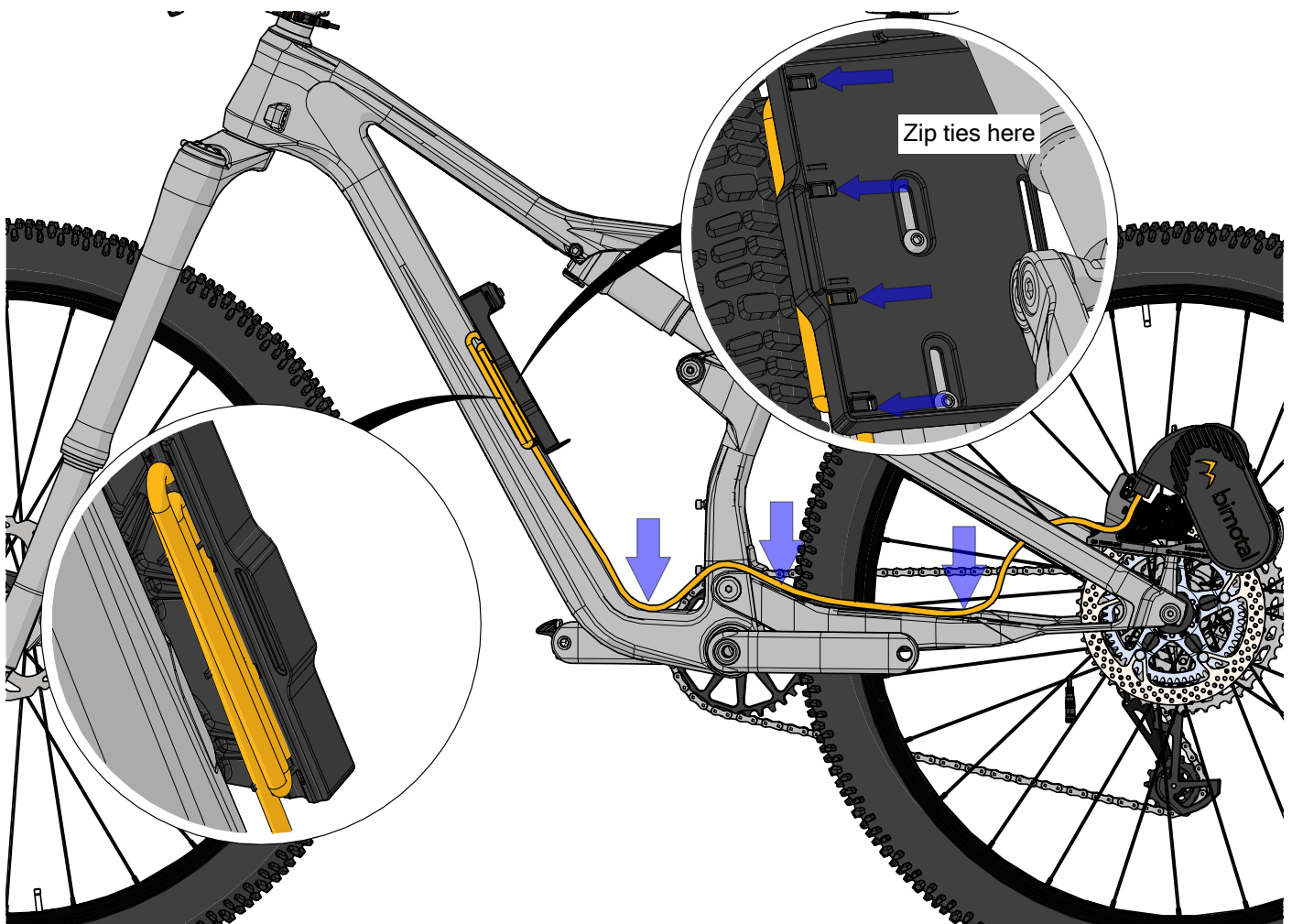

9) Make sure the battery harness is guided behind the seat stay, on top of the chain stay, over the bottom bracket and on the left side of the downtube. Wrap the excess harness as shown in the illustration and clamp it to the battery tray using zip ties. Zip tie the harness thoroughly on the areas indicated with blue arrows in the picture. Place the zip tie heads pointing down in the Battery Tray to avoid any interference with the Battery.

**CAUTION:** Ensure that the harness won't get pinched during suspension travel, that it is not possible to move into the wheel spokes, and that the user's pedal, legs, shoes, etc. will not get caught on the harness during normal operation and pedaling of the bike. It is often helpful to route it along hydraulic brake caliper lines on the chainstay or seat stay.

Use flush cuts to trim the zip ties such that there is no sharp point protruding from the zipped bundle that could cut or scrape the user's leg.

# BATTERY TRAY AND ELECTRICAL CONNECTOR INSTALLATION

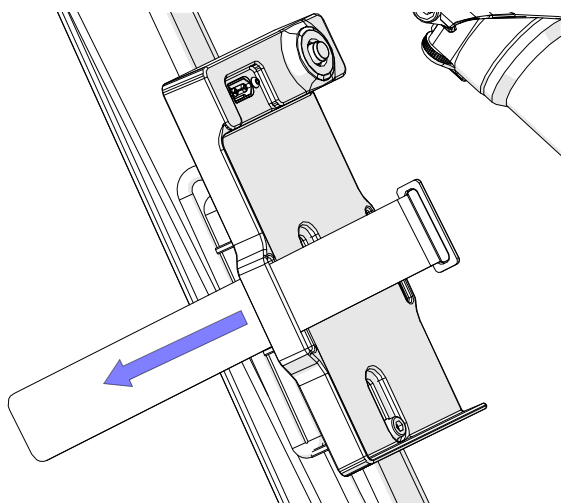

10) Insert a Velcro strap in the left hole of the Battery Tray. Make sure the Velcro side is facing out.

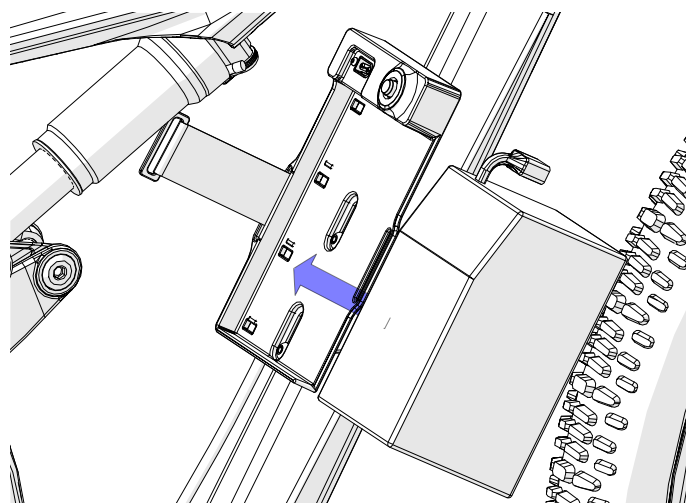

11) Slide a Battery into the Battery Tray.

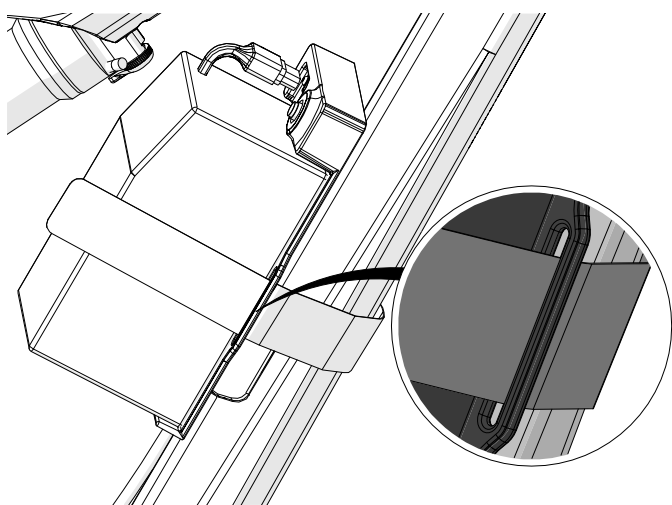

12) Guide the Velcro strap under the downtube of the frame and insert it into the hole on the right side of the Battery Tray.

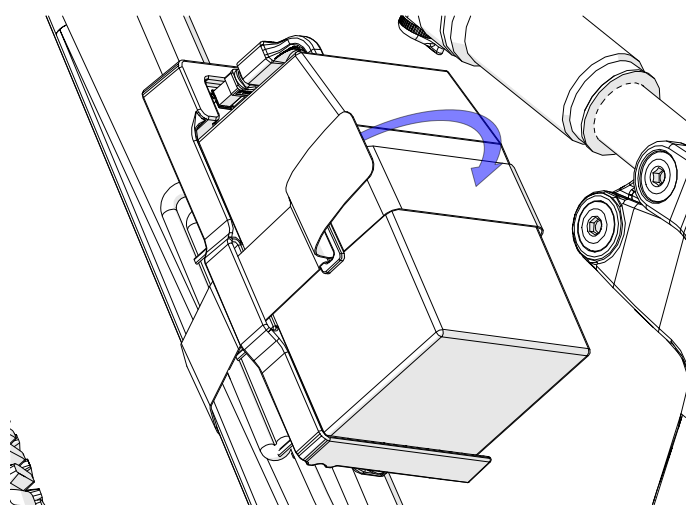

13) Place the Velcro strap through the plastic buckle and fasten it to securely hold the Battery in place.

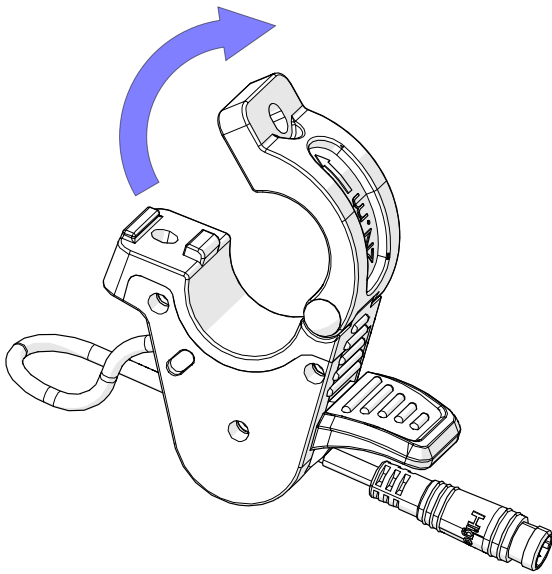
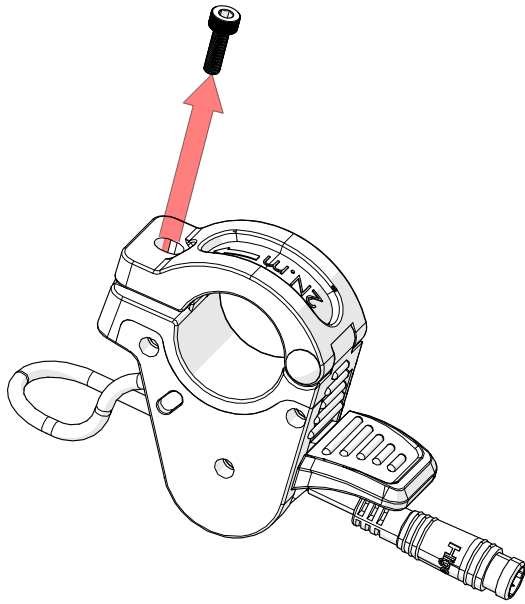

1) Remove the mounting screw on the Throttle and

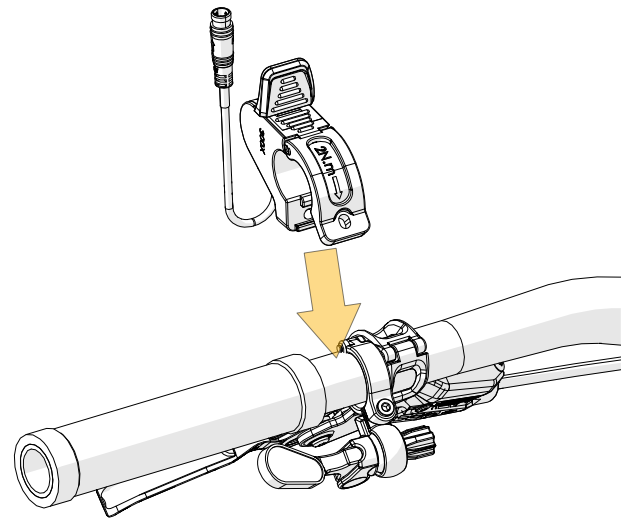

2) Install the Throttle on the handlebar. Bimotal recommends installing the Throttle on the left side to enable shifting with the right hand while applying throttle with the left hand.

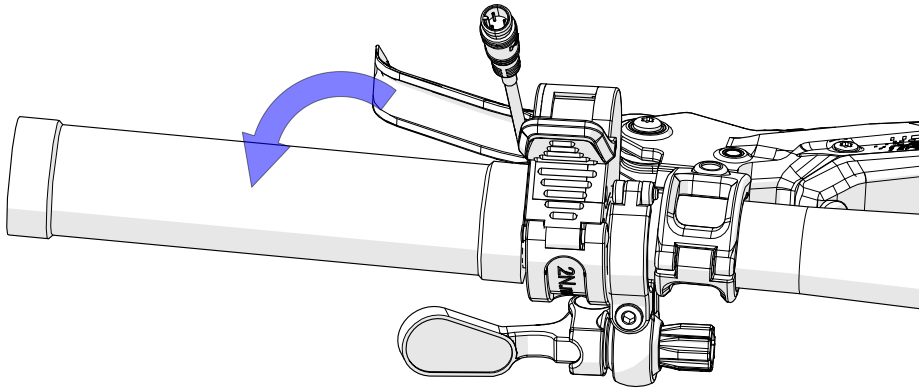

3) Ensure clearance with dropper levers, brake levers, and that the user can still easily use the brakes without the Throttle interfering with the brake lever in any way.

Note: the throttle can be installed such that the lever is pushed down with the thumb or such that the lever is lifted with the thumb knuckle.

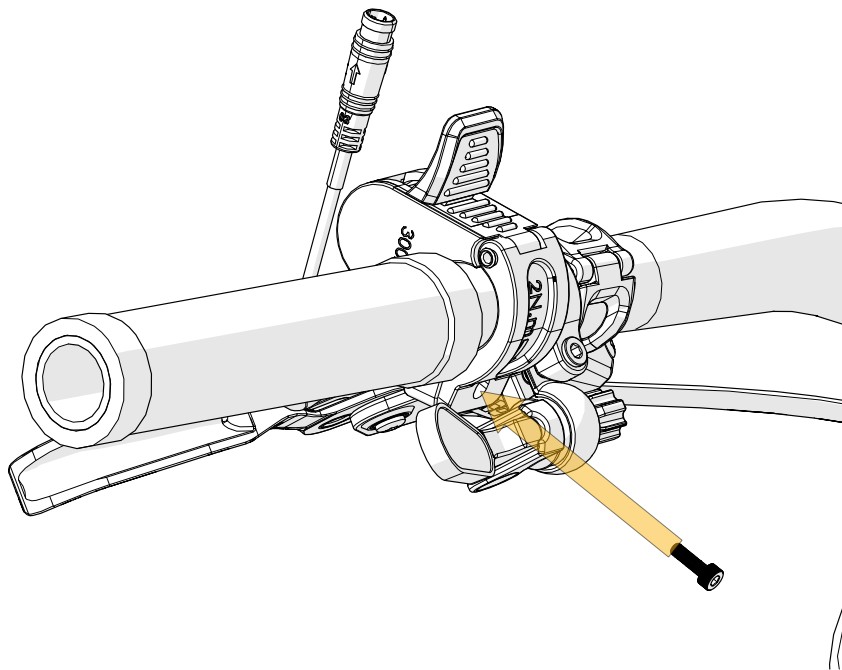

4) Tighten throttle screw to 2 Nm.

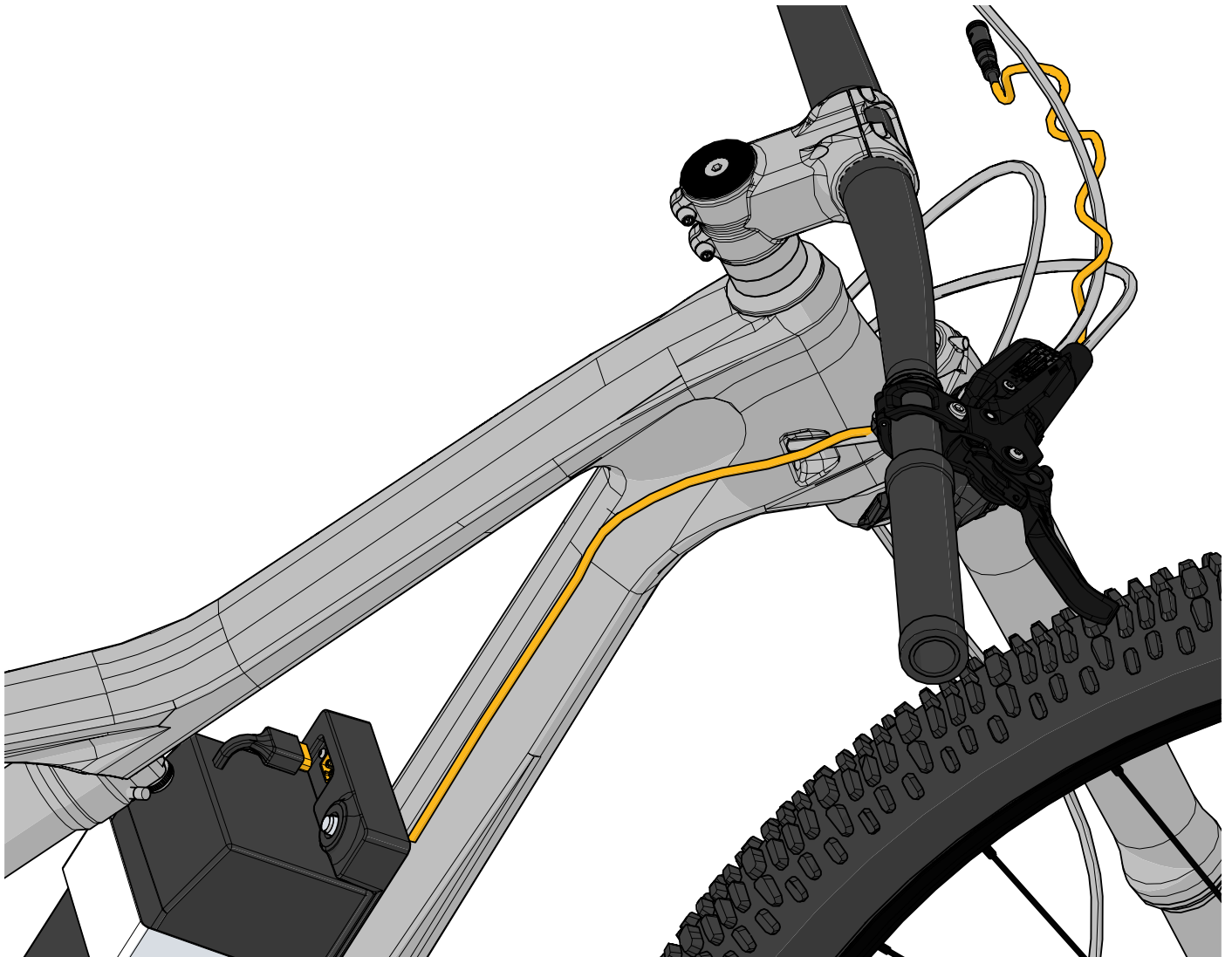

## WARNING:

Using a torque lower than 2 Nm poses a safety risk, as it may cause the throttle to rotate and obstruct the brake lever.

5) Guide the throttle harness from the battery tray to the cockpit area where the throttle was installed. Zip tie the harness on the side of the downtube. Wrap the harness around the brake wires as in the picture.

If customer prefers, harness can be routed along brake harness without wrapping for a different aesthetic, ensure full lock-to-lock

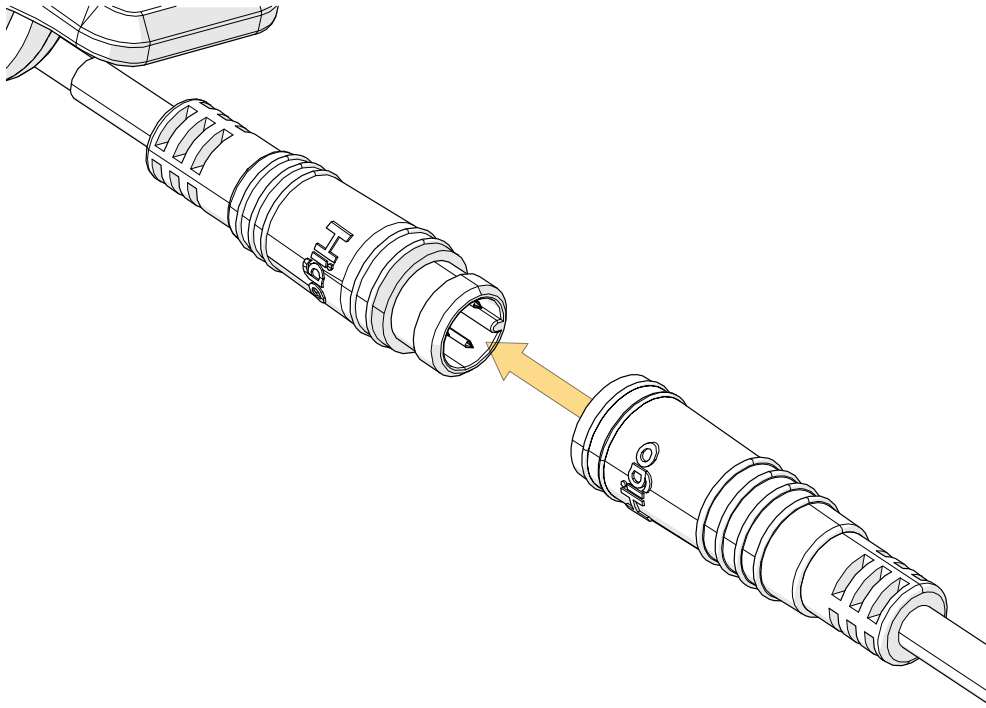

6) Connect the male HIGO connector on the throttle with the female HIGO on the battery tray harness.

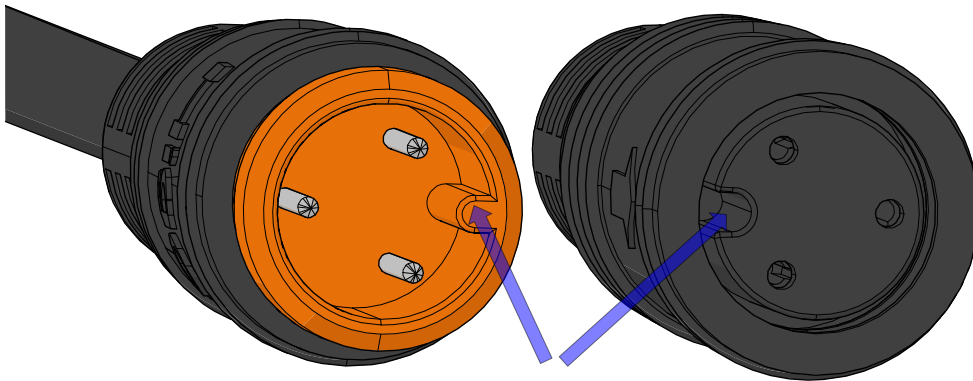

Align these features when connecting female and male connectors



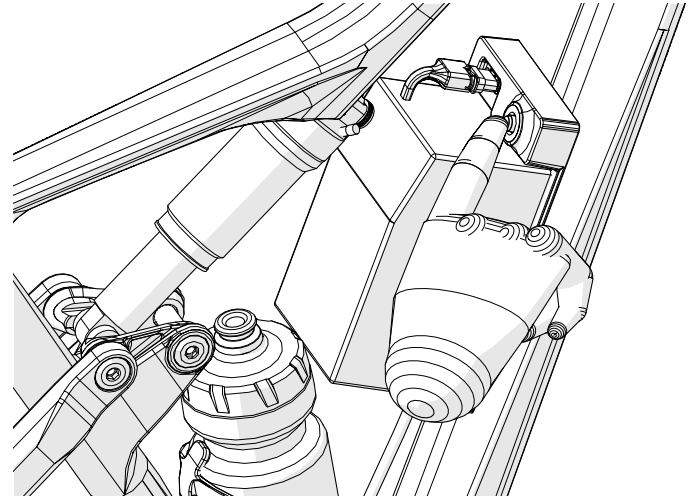
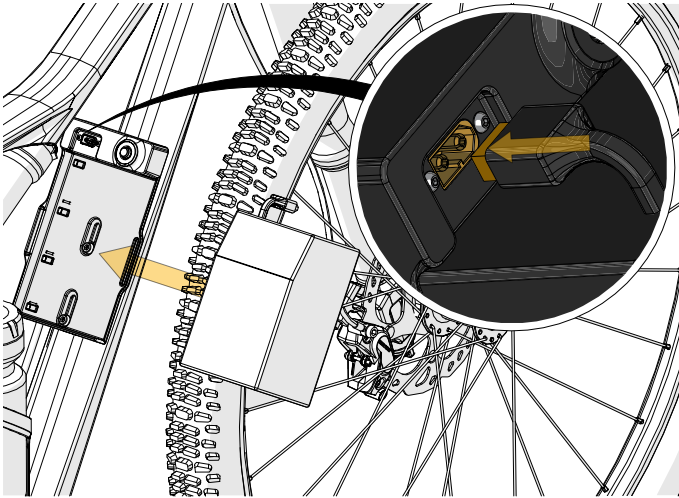

1) Connect the battery to the Battery Tray.

2) Turn the Battery Tray switch on.

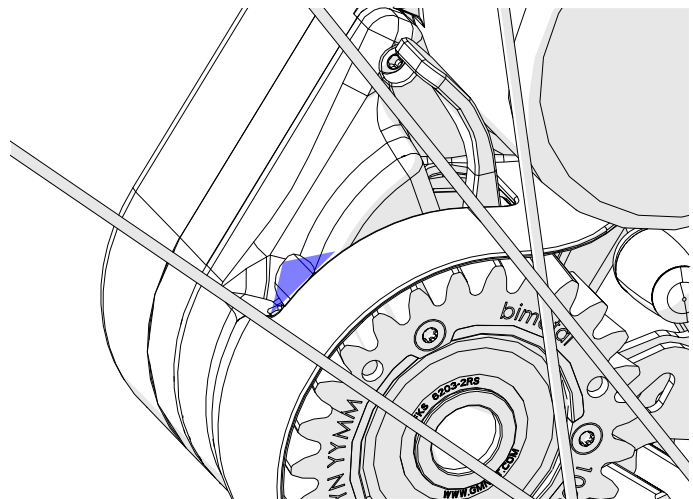
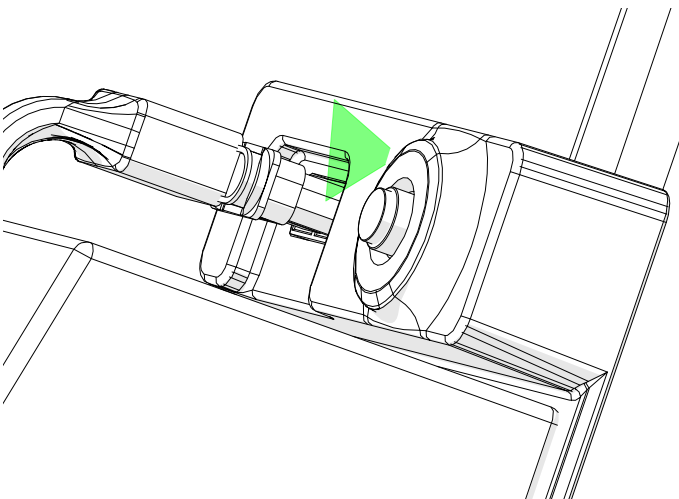

3) Ensure the battery tray green LED switches on. The Elevate Drive Unit should also have a blue light on, visible from the drive side of the bike (see picture).

4) It is recommended to briefly bed the brakes in, which also serves as a functional check. Mount the bike on a bike stand. Ensure all fingers, clothing, and hair are clear of all spinning parts before bedding brakes. Push the throttle lever fully down and apply light brake pressure for 60 seconds. Release the brake. Continue to hold the throttle fully down and apply 5 brake pulses about 5 seconds long each, releasing the brake for a few seconds between each pulse but still keeping the throttle on. It is okay to stall the motor as the unit is temperature and current protected. The last pulse can bring the wheel fully to a stop and release

## After installing the Elevate system, verify the following:

1. Final safety check
  - a. Test ride bike
  - b. Ensure that Elevate works
  - c. Confirm brakes work
2. Confirm brake rotor does not scrape brake pads
3. Fill out [Post-Installation Checklist](#)

## When the customer picks up their bike, show them how to use their Elevate system:

1. How to turn Elevate on/off
2. How to secure Battery to Battery Tray
3. How to plug/unplug Battery connector to Battery Tray
4. How to use the Throttle
5. How to take Elevate on/off bike
6. Point out that if they move their controls that they need to be aware of brake lever-throttle interference to prevent brake lever from contacting throttle body without generating full braking pressure
7. Return original brake rotor, brake caliper adapter if there was one, and bottle cage if there was one

## Finally, have the customer submit the [Customer Pickup Checklist](#):

- 8 I know how to turn on my system
9. I know how to operate the throttle
10. I release the installer from liability



Your elevate system is now installed! Please ride respectfully and on legal trails.

**HAPPY TRAILS FROM THE BIMOTAL TEAM**



ELEVATE INSTALLATION INSTRUCTIONS

Copyright © 2023 bimotal Inc. All rights reserved. Designed by bimotal in California.  
Contact: [service@bimotal.com](mailto:service@bimotal.com)