

# vortex

Cyclone dust collector with High Pressure fan

Innovative  
Efficient  
Powerful  
Made in Italy



ALFARIMINI

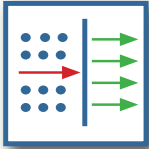

**High efficiency filtration**  
wide range of filtering media  
- Filtering bags  
- Filtering cartridges IFA-BGIA [M]

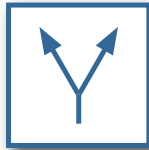

**Safety**  
It's impossible to touch the fan with your hands

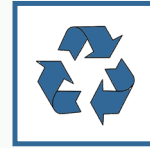

**Energy saving motors**  
IE 2 - IE 3 - IE 4



**Wide cyclone, very efficient**



Collecting bags for fine dust made in **Recycled Polyethylene LDPE**



**Inspection porthole**



**Wheels with brake**



**Bin with quick/release hook**



**Innovative vacuum system**  
no flex hose is required to put in depression plastic collecting bags

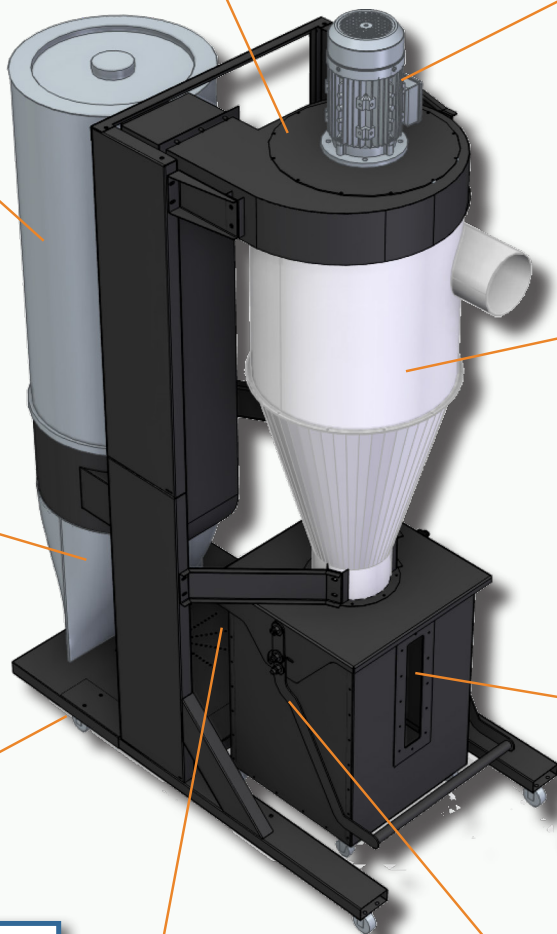

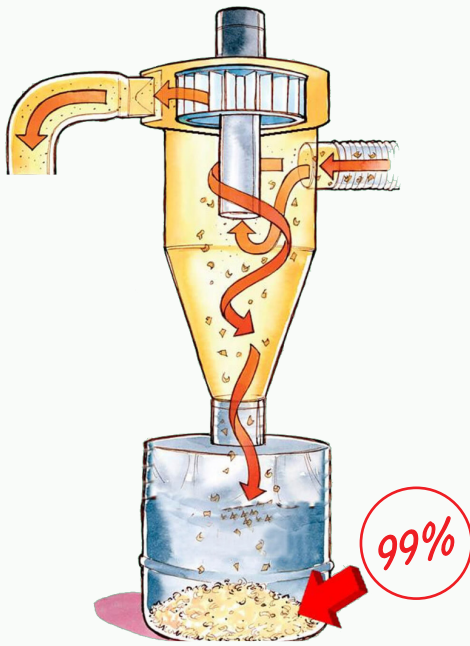

**EASY INSTALLATION**  
can be pre-assembled



All components are  
**certified**



Available in  
**three models**



**Design for:**  
wood - plastic - metal

## HOW IT WORKS

The dusty air enters the **VORTEX** through the extraction inlet of the cyclone.

Thanks to the cylindrical and then conical shape, the air flow is forced into downward spiral motion.

As a result of the centrifugal force, the particles separate from the gas flow that contains them and are dragged by the force of gravity towards the lower part of the filter where they are collected.

The finer particles that remain in suspension are extracted and through the inner cylinder, pushed by the fan into the filter body and retained and collected here.

The percentage of dust captured by the cyclone is much greater than that ending up in the final container, in a ratio that can reach up to 99% of the total, depending on the grain size and physical characteristics of the dust or chip extracted.

## INNOVATIVE AND POWERFUL

**VORTEX** is the first cyclone filter entirely manufactured in Italy.

The cyclone is an efficient separation system for dust, normally used for large systems.

**VORTEX** is an innovative product because it integrates the cyclone separator in a compact machine.

Finally you will avoid all the extracted dust ending up in the filter module, quickly clogging it and reducing extraction.

With your **VORTEX** filter, you will not lose power even after days of intense work.

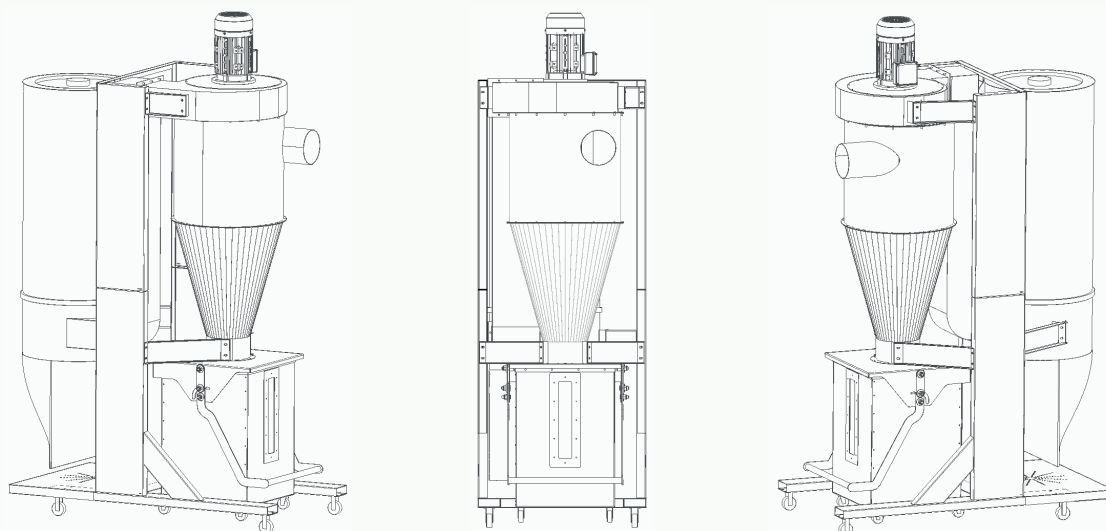

MODELS	Motor Power	MAX Air flow	MAX Pressure	Suction hood	Filtering bag	Filtering surface	Bidone di Raccolta	Dimensioni
	kW - [HP]	m <sup>3</sup> /h	mmH <sub>2</sub> O	Ø mm	n.	m <sup>2</sup>	Lt	mm
<b>VORTEX 320</b>	1,1 - [1,5]	1.500	230	120	1 x Ø 350	1 ± 4,6	110	1000 x 700 x 1800
<b>VORTEX 370</b>	1,5 - [2]	2.200	240	140	1 x Ø 450	1,5 ± 9	140	1200 x 800 x 2000
<b>VORTEX 440</b>	2,2 - [3]	2.800	260	200	1 x Ø 500	2,2 ± 10	160	1400 x 800 x 2200

**JACCRA INDUSTRIES**

**Imported by Jaccra Industries Pty Ltd**  
23 Exhibition Drive, Malaga Western Australia

**Sales + Support**  
[www.jaccraindustries.com.au](http://www.jaccraindustries.com.au)

#### SAFETY STANDARDS AND REGULATIONS

consult your local authorities to verify all governing codes and regulations that apply in your locality in regards to the use of enclosureless dust collectors. It is the buyer's responsibility to follow all applicable national, local codes and regulations for installation and system operation.