

# '67-69 Original Big Block A-Body B/RB Engine Mount Kit

## INSTALL BRACKETS AS SHOWN:

We strongly suggest that you purchase a Factory Service Manual for your car's year and model. This will be an invaluable tool for the success of your project.

**Adjustability:** All Chrysler motor mounts have 1/2" holes and 7/16" fasteners for mounting to the engine lugs, and the mounting points on most K-members have over-sized holes. This is to build adjustability into the bracket and insulator assembly allowing for side to side movement, height, leveling, etc. By installing the motor mount assembly finger-tight only (bracket to engine and insulator to k-member) a hoist can be used to shift the engine for optimum clearances and position. Adjustment can also be attained by pulling the motor mount assembly away from or pushing it toward the engine. You will notice approximately 1/4"+ movement. The tranny should be installed and loosely fastened to the crossmember, as this is the third mounting point and is critical to engine placement. All fasteners can be torqued to factory specs after the desired position is attained.

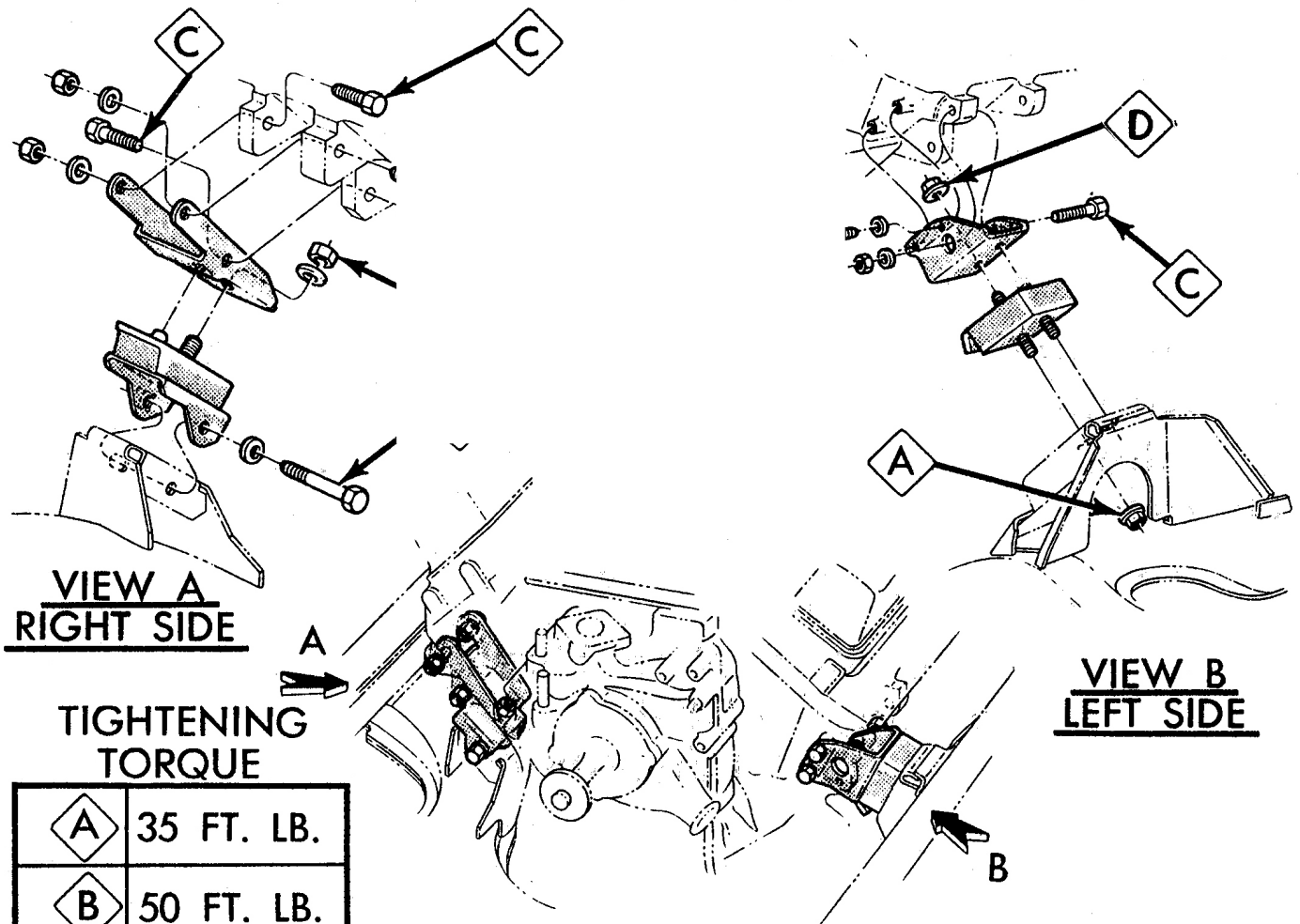

**VIEW A  
RIGHT SIDE**

**VIEW B  
LEFT SIDE**

### TIGHTENING TORQUE

<b>A</b>	35 FT. LB.
<b>B</b>	50 FT. LB.
<b>C</b>	55 FT. LB.
<b>D</b>	75 FT. LB.

*Schumacher Creative Services*

41715 Elm St. Suite 301

Murrieta, Ca 92562

951.440.8340 info@engine-swaps.com