

INSTRUCTIONS

'67-72 A-Body Big Block Conversion

Thank you for your purchase! We strongly suggest purchasing a factory service manual for the correct year and model of the vehicle you're working on. This will be an invaluable tool for the success of your project.

Note: Your brackets and rubber isolators are marked with an "L" sticker for the left side. The isolator mounts forward hanging off the bracket slightly, with the dimple facing up. The cut isolator goes on the driver side for oil pump clearance.

Bracket Installation: Install rubber isolators to metal brackets using supplied hardware. Dimples facing up. The cut isolator mounts on the driver side for oil pump clearance. Torque isolator to bracket per service manual. Install bracket and rubber isolator assembly to engine as shown. Tighten fasteners finger tight only to allow for greater adjustability. You will torque all fasteners after proper adjustment has been achieved.

Engine Installation: Lower engine and install as outlined in the factory service manual.

Engine Leveling/Adjusting: Make sure the vehicle is on level ground prior to leveling the engine. A 4 foot bubble level can be used across the valve covers to check for proper level. All Chrysler motor mounts have 1/2 inch holes and 7/16 fasteners for mounting to the engine lugs. Most K-member mounting holes are oversized as well. This is to allow for engine adjustability and poor factory manufacturing tolerances. By installing the engine brackets finger tight a hoist or floor jack can be used to shift the engine into its proper location. The transmission mount and crossmember should also be installed loosely to aid in adjustability. Once desired engine level is achieved, tighten all hardware to specified torque in your Factory Service Manual.

Final Notes: Every effort has been made to insure correct engine placement. Due to sloppy tolerances from the factory when building K-members (no two are exactly the same), there may be an instance where achieving proper fit requires more than bolting on the brackets, holes in the brackets or K-members may need to be enlarged for proper fit. If you need further technical assistance, please call or text 951-440-8340. E-mail tech support is also available at info@engine-swaps.com.

VIEW RIGHT SIDE

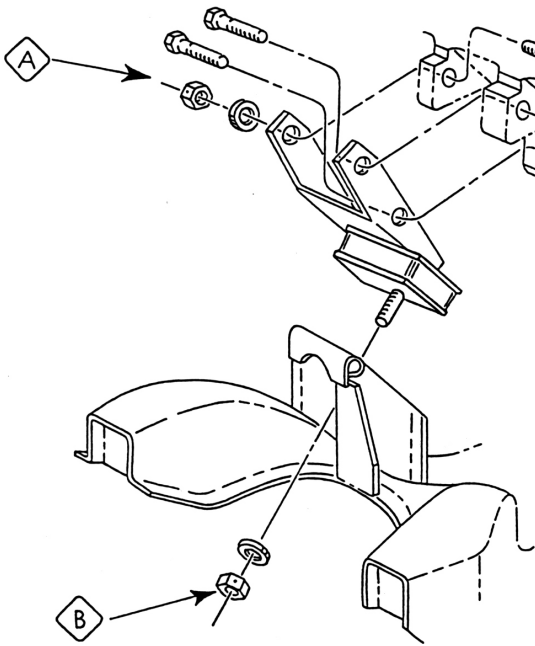

V8
K-MEMBER

A	55 FT. LB.
B	75 FT. LB.

VIEW LEFT SIDE

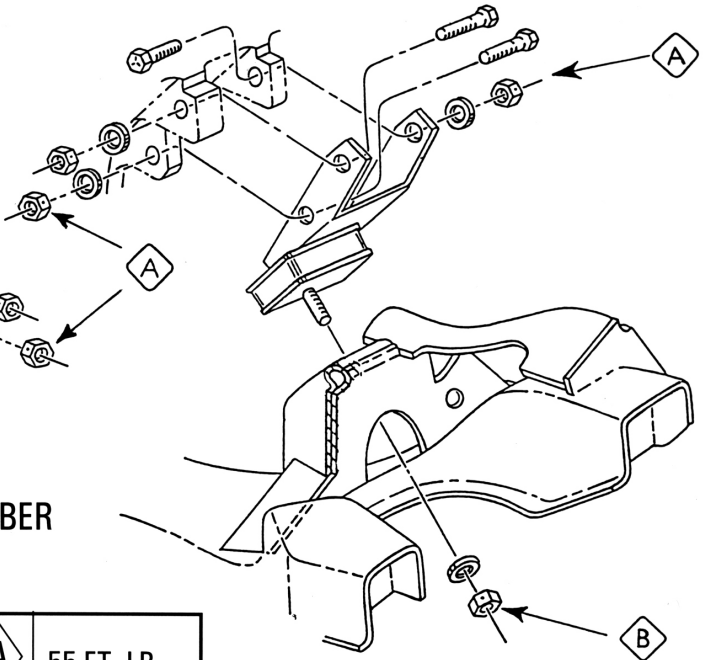

VIEW RIGHT SIDE

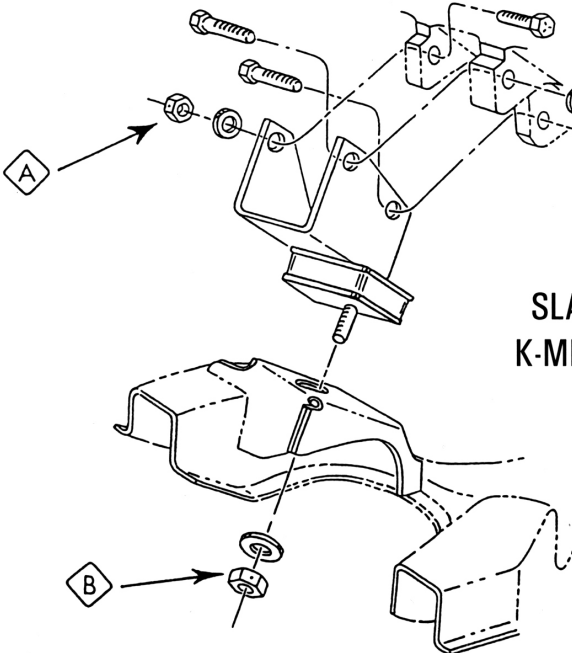

SLANT 6
K-MEMBER

A	55 FT. LB.
B	75 FT. LB.

VIEW LEFT SIDE

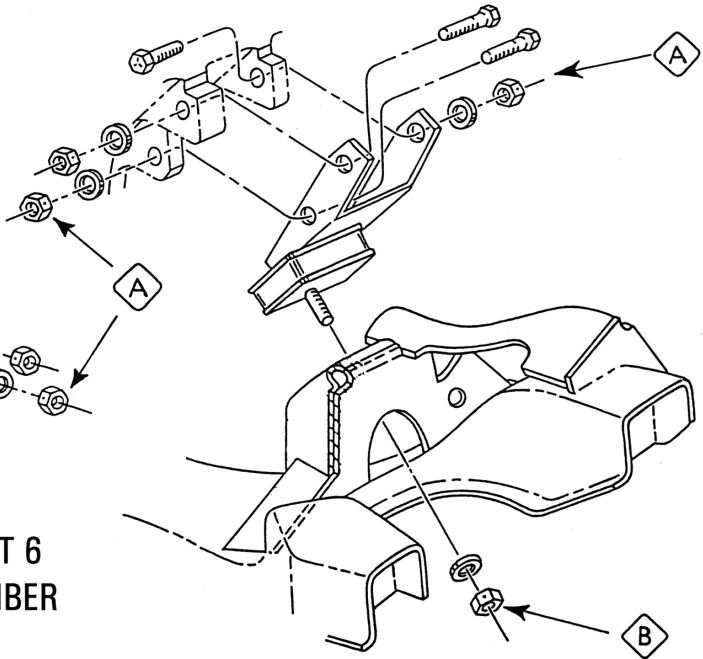

The driver's side engine mounting perch needs a notch for oil pump clearance. (Drawing is actual size and can be used as a template.)
Note: The Mellings and High Performance Mopar oil pumps are 1/4" thicker than the factory oil pump. If you are using either, you will have to locate the notch slightly higher on the perch, and it may need to be deeper.

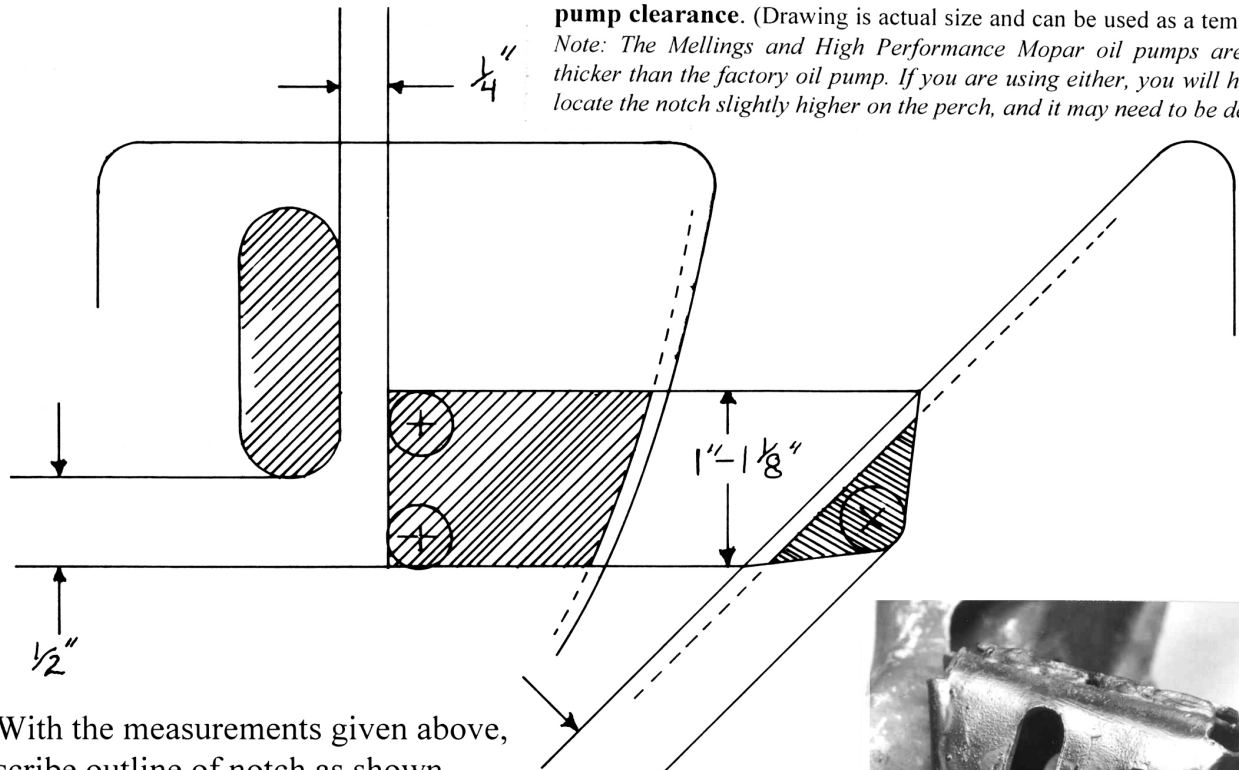

With the measurements given above, scribe outline of notch as shown.

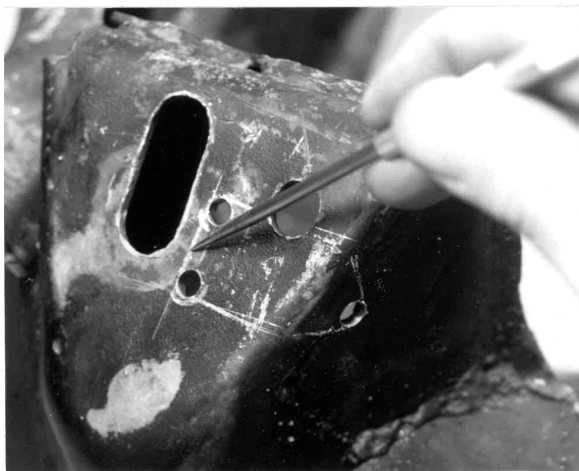

FINISHED NOTCH

In the example given I used a cut-off wheel with the holes drilled to define the corners. A sawsall can also be used, using the same holes for blade access.

After the notch is cut, a die grinder can be used to radius the edges, round corners and deburr.

In high-performance applications a reinforcement plate should be fabricated and welded to this area.

In extreme high performance applications an alternative to this notch would be to remove a greater amount of material from the perch area (as shown) and to weld a reinforcement plate into this area.

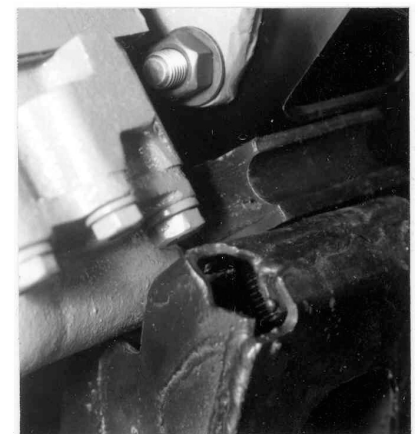
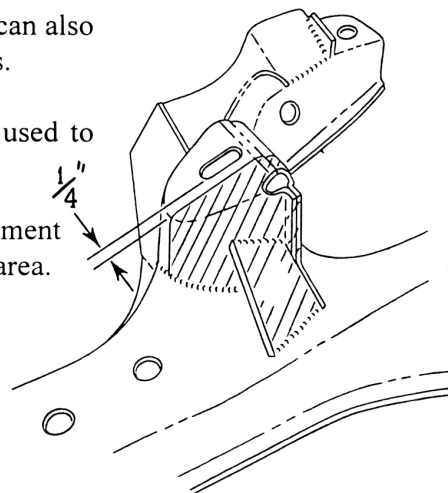

HOW IT WORKS



Warranty

Warranty is limited to workmanship and materials of this product. We will repair or replace any defective part or component at no cost to the customer.

Customer assumes all risks and responsibilities connected with the use of this product. In purchasing this product, the customer understands that Schumacher Creative Services cannot be held responsible for injury or physical damage due to improper installation or use.

Tech Notes:

- The oil pan must be low profile, center sump style. This is standard on most passenger cars. For an A-body swap we recommend the 66-73 C-body oil pan, #187 or #699.
- Most aftermarket aluminum valve covers are taller than production style valve covers. In some instances this will cause an interference with the blower motor on A-Bodies.
- On some models this conversion may interfere with factory A/C components.
- Some aftermarket heads have reconfigured port designs. This can cause the header to be in a different position, causing fitment issues. Trial fit may be required.
- **A-Body 440 Conversions:** Because the 440 conversion is a very tight fit in an A-body, exhaust options are more limited. Some modification may be required. Factory Big Block A-Body manifolds work perfectly, but can be difficult to find.
- **Header Considerations:** Installation of large diameter headers, both under chassis and fender well may require some fabrication/modification and patience to make work. In most cases you will need to convert to manual steering to make these headers fit. We offer a Tri-Y style, under chassis header that fits well and does not require extensive modification to make fit.
- **A-body 383/400 Conversions:** These conversions allow for more room for exhaust fitment. Some factory B/C-Body HP or log style manifolds fit with no issues. You may have to determine the best combination for your vehicle. Possible dimpling on the passenger side inner fender to clear the collector may be required.

Schumacher Creative Services inc.

41715 Elm St. Suite 301
Murrieta, Ca 92562
951.440.8340

ig: schumacher_creative_services fb.com/engine-swaps info@engine-swaps.com