

# INSTRUCTIONS

---

## '63-66 A-Body 273/318/340/360 Conversion

**Thank you for your purchase! We strongly suggest purchasing a factory service manual for the correct year and model of the vehicle you're working on. This will be an invaluable tool for the success of your project.**

**Note:** Your bracket should be marked with an "L" sticker for the left side. If not, the bracket with 1-3/8" access hole is the right (passenger) side.

**Bracket Installation:** Install rubber isolators to metal brackets using supplied hardware. Torque isolator to bracket per service manual. Install bracket and rubber isolator assembly to engine as shown. Tighten fasteners finger tight only to allow for greater adjustability. You will torque all fasteners after proper adjustment has been achieved. Rubber isolator stud should be offset towards the front of the vehicle.

**Engine Installation:** Lower engine and install as outlined in the factory service manual.

**Engine Leveling/Adjusting:** Make sure the vehicle is on level ground prior to leveling the engine. A 4 foot bubble level can be used across the valve covers to check for proper level. All Chrysler motor mounts have 1/2 inch holes and 7/16 fasteners for mounting to the engine lugs. Most K-member mounting holes are oversized as well. This is to allow for engine adjustability and poor factory manufacturing tolerances. By installing the engine brackets finger tight a hoist or floor jack can be used to shift the engine into its proper location. The transmission mount and crossmember should also be installed loosely to aid in adjustability. Once desired engine level is achieved, tighten all hardware to specified torque in your Factory Service Manual.

**Final Notes:** Every effort has been made to insure correct engine placement. Due to sloppy tolerances from the factory when building K-members (no two are exactly the same), there may be an instance where achieving proper fit requires more than bolting on the brackets, holes in the brackets or K-members may need to be enlarged for proper fit. If you need further technical assistance, please call or text 951-440-8340. E-mail tech support is also available at [info@engine-swaps.com](mailto:info@engine-swaps.com).



**RIGHT SIDE**

**340/360**

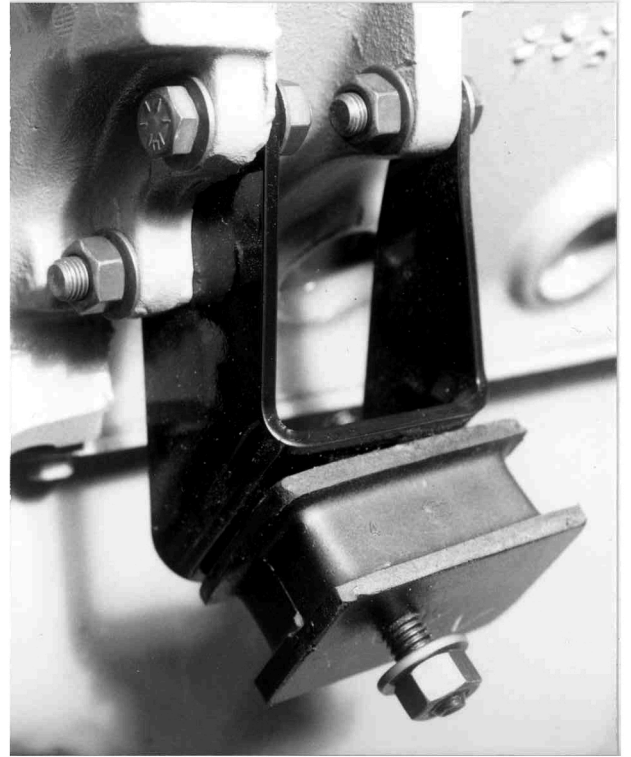

**LEFT SIDE**

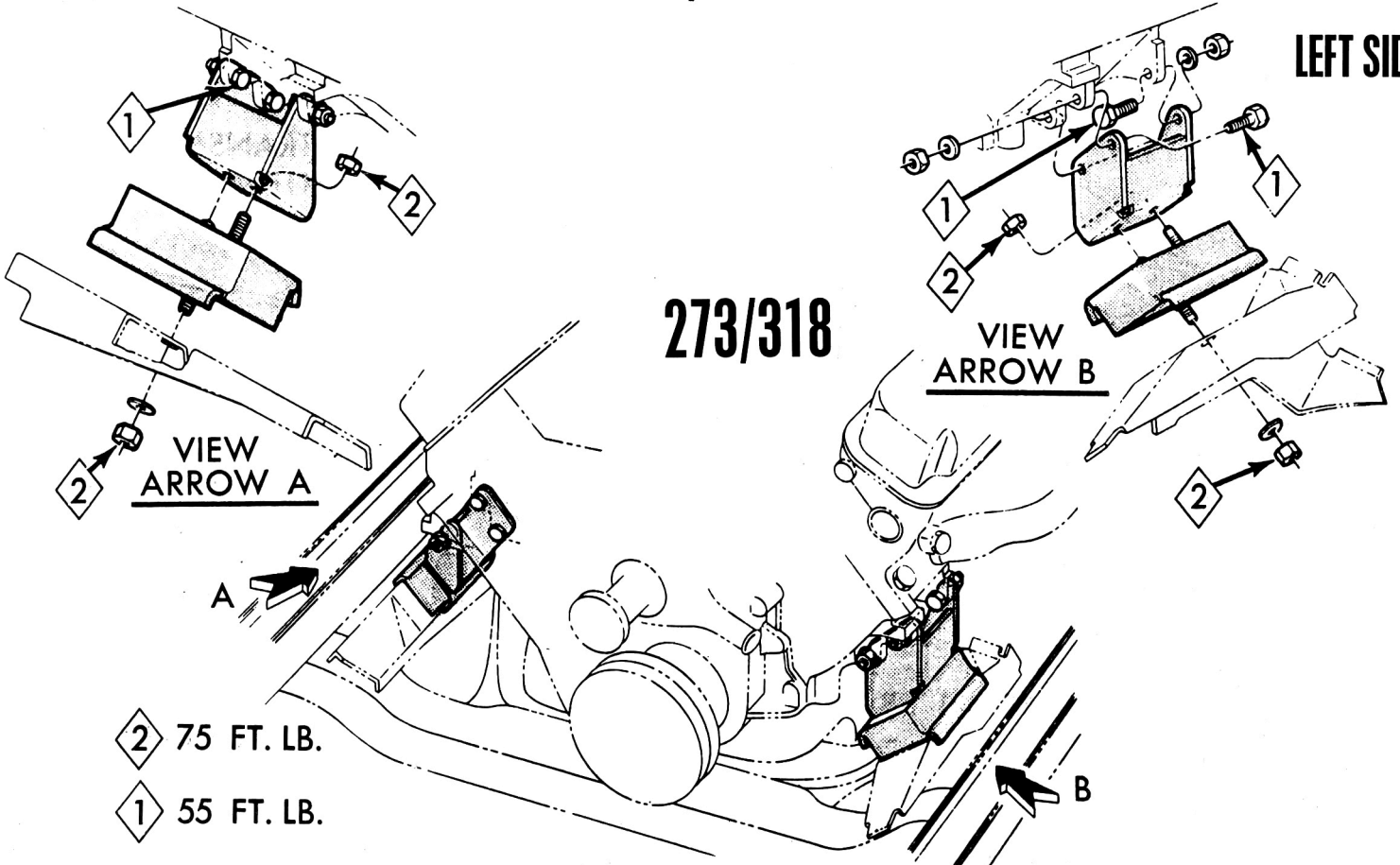

## Tech Tips For Early A-Body Small Block Conversions

- The best tech tip we can possibly give is to purchase a Factory Service Manual for the Year and Model of your vehicle.
- The oil pan must be a low profile, center sump style - This is standard on most passenger cars. Please note 273, 318, and 340 oil pans are not interchangeable with a 360.
- On Slant 6 models, we recommend changing to a V8 steering centerline. This will add more oil pan clearance. Any V8 centerline from 64-72 A-Bodies will interchange. You can identify the center link visually: The Slant 6 will appear straight, while the V8 centerline will have a drop of approximately 1-3/4 inches.
- '63 model year vehicles may require modification of the firewall area for distributor clearance.
- Due to the narrow engine compartment, the driver side exhaust manifold will have to be 274 style. Tight clearances will not allow the use of 340/360 style manifolds. Driver side 273 manifold has a casting number: 2465847.
- The 727 transmission will require the pinch weld in the transmission tunnel to be flattened. This will leave approximately 1/8" of clearance.

### Warranty

Warranty is limited to workmanship and materials of this product. We will repair or replace any defective part or component at no cost to the customer.

The customer assumes all risks and responsibilities connected with the installation and use of this product. In purchasing this product, the customer understands that Schumacher Creative Services Inc. cannot be held responsible for any injury, death, or physical damage due to installation or use of this product.

*Schumacher Creative Services Inc.*

41715 Elm St. Suite 301, Murrieta, Ca 92562  
951.440.8340 info@engine-swaps.com