

LINEAR ACTUATED MOBILE TILTING WORK TABLE - WT-2424-LA

APPROX WEIGHT: 110.67 lbs.
DOES NOT INCLUDE WEIGHT OF POWER OR PACKAGING!!!

*** ANY ADDITIONS, DELETIONS, OR OMISSIONS MUST BE CORRECTED ON THIS DRAWING AS THIS DRAWING WILL BE CONSIDERED ALL INCLUSIVE ***
ALL GRAPHICS PROVIDED ARE FOR REFERENCE ONLY. IF CERTAIN DIMENSIONS ARE CRITICAL PLEASE VERIFY THOSE DIMENSIONS WITH YOUR SALESPERSON

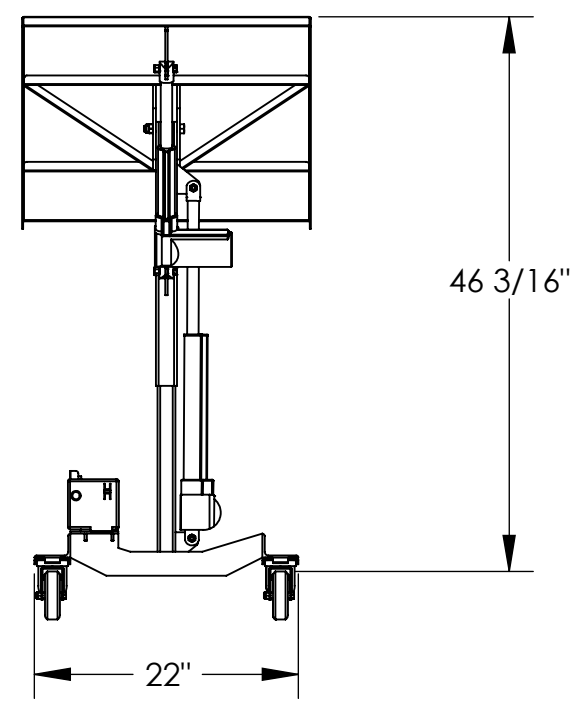
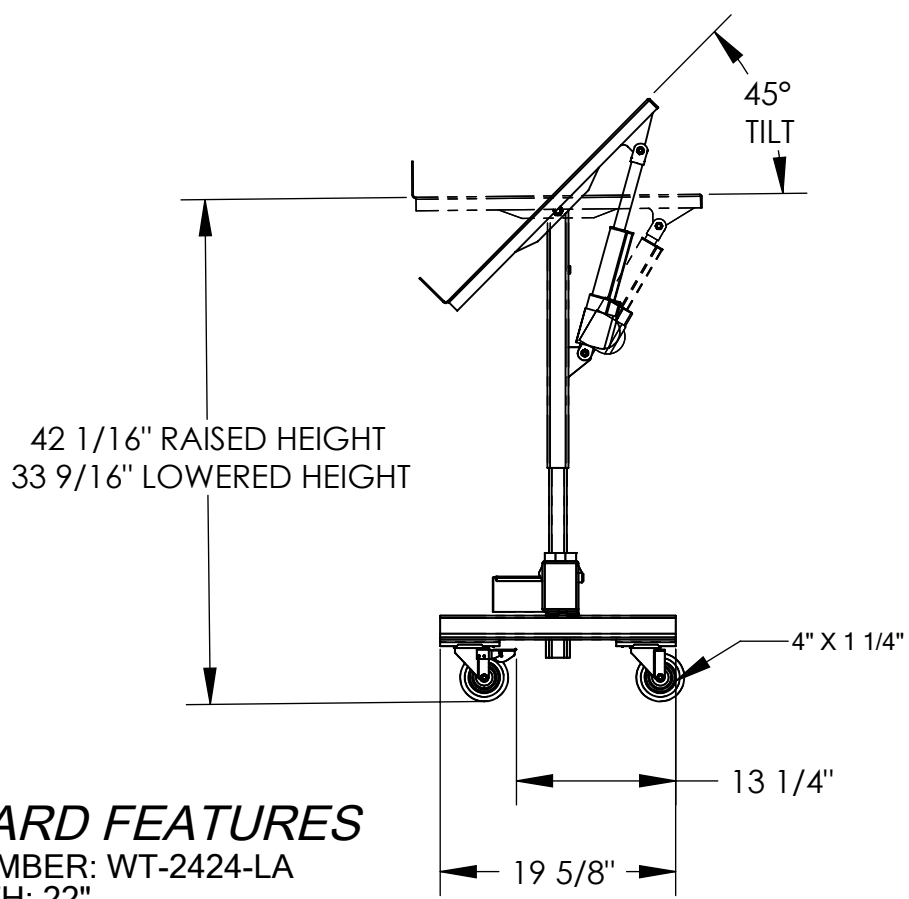

DIMENSION TOLERANCE ± 1/4"

STANDARD FEATURES

- MODEL NUMBER: WT-2424-LA
- BASE WIDTH: 22"
- BASE LENGTH: 13 1/4"
- RAISED HEIGHT: 42 1/16"
- LOWERED HEIGHT: 33 9/16"
- CAPACITY: 300 LBS
- PLATFORM WIDTH: 24"
- PLATFORM LENGTH: 24"
- DEGREE OF TILT: 45°
- TWO SWIVEL 4" X 1 1/4" POLYURETHANE DOUBLE-LOCKING CASTERS (FRONT)
- TWO SWIVEL 4" X 1 1/4" POYURETHANE CASTERS (REAR)

NOTE: DEWERT FOUR BUTTON HAND CONTROL NOT SHOWN

SPECIAL FEATURES

NONE

APPROVAL	I, THE UNDERSIGNED, AGREE THAT THE PRODUCT AS REPRESENTED SATISFIES DESIGN AND DIMENSION REQUIREMENTS. I ALSO ACKNOWLEDGE MY DUTY TO CONFIRM PRODUCT AND INSTALLATION COMPLIANCE WITH ALL APPLICABLE FEDERAL, STATE AND LOCAL REGULATIONS AND STANDARDS.	
	ANY MODIFIED UNITS ARE NON-RETURNABLE	
	[] As drawn [] As marked	
	Signed: _____	Date: _____
Printed Name: _____		
LEAD TIME WILL START UPON RECEIPT OF SIGNED APPROVAL DRAWING		

FOR INTERNAL USE ONLY PROJECT SIGN OFF	
SALES	
ENG.	
FAB.	
POWER	

DISTRIBUTOR'S NAME:		P.O.#
VESTIL MANUFACTURING		X
DRAWN BY: X		W.O.#
DATE: XX/XX/XX		X
REFERENCE: X	SCALE: 1:16	SALES: X
QUOTED LEAD TIME: X	QUOTE #	FILE NAME:
	X	16-007-022