

SCISSOR DOCK LIFT - WL-100-12-712

STANDARD FEATURES

MODEL NUMBER: WL-100-12-712
 UNIT TO BE MOUNTED: AT SURFACE OR IN PIT (CIRCLE ONE)
 CAPACITY (EVENLY DISTRIBUTED): 12,000 LBS
 AXLE END LOAD CAPACITY IS: 9,750 LBS
 AXLE SIDE LOAD CAPACITY IS: 8,500 LBS
 OVERALL PLATFORM SIZE: 7' (84") x 12' (144")
 USABLE PLATFORM SIZE: SEE DIAGRAM
 RAISED HEIGHT: 72"
 LOWERED HT: 14"
 REMOVABLE HANDRAILS 45" HT W/ 21" MIDRAIL
 AND 4" TOEBOARD, TOE BOARDS ARE: NON-REMOVABLE
 TRUCK BRIDGE IS 72" W x 18" L
 W RUN OFF GUARDS, CHAINS & HANDLES

SHIPPING WT IS: 7,320 LBS

6½ HP POWER UNIT (SEE BOTTOM LEFT CORNER) W/ 8' OF HYDRAULIC HOSE

- 24 VAC HAND-HELD CONTROL ON A 4'-20' COIL CORD

REFER TO THE UNIT'S ELECTRICAL DIAGRAM FOR ELEC. SERVICE REQUIREMENTS

- INSTALL TO MEET ALL APPLICABLE STATE & LOCAL CODES FOR YOUR AREA!

5" BEVELED TOE GUARD WITH ELECTRIC TOE GUARD

- THE ELECTRIC TOE GUARD AND UPPER LIMIT SWITCH CIRCUITS MUST BE COMPLETED

BY INSTALLING AN 18/5 STD (OR EQUIV.) CABLE BETWEEN THE POWER UNIT
 AND THE JUNCTION BOX LOCATED IN THE LIFT'S FRAME

UP SPEED AT FULL CAPACITY IS 4.3 SECONDS PER FOOT (@460 THREE PHASE)

FOR WARRANTY INFO SEE FORM WTY-91

**ARCHITECTURAL REVIEW FOR CORRECTNESS OF PIT AND FOR
 COMPLIANCE TO LOCAL AND STATE CODES IS RECOMMENDED.**

* Optional Features: (Available at additional cost)

- | | |
|--|--|
| <input type="checkbox"/> Dual speed hydraulic pump | <input type="checkbox"/> Flush removable handrails and toeboard |
| <input type="checkbox"/> 2 HP single or three-phase power unit | <input type="checkbox"/> Additional split steel bridge |
| <input type="checkbox"/> 3 HP single-phase power unit (1½ GPM) | <input type="checkbox"/> Split aluminum truck bridge |
| <input type="checkbox"/> 7½ HP three-phase power unit (4.5 GPM) | <input type="checkbox"/> Four-sided accordion skirt (customer
installs) |
| <input type="checkbox"/> 10 HP three-phase power unit (6 GPM) | <input type="checkbox"/> Wheel and dolly jack kit (6,000# max. capacity) |
| <input type="checkbox"/> Control lockout key switch | <input type="checkbox"/> Automatic wheel chocks |
| <input type="checkbox"/> Warning beeper during travel | <input type="checkbox"/> Stop signal sign |
| <input type="checkbox"/> Warning strobe during travel | <input type="checkbox"/> Steel approach ramp (___" x ___") |
| <input type="checkbox"/> Oil immersion heater w/ t'stat | <input type="checkbox"/> Cold galvanized deck and frame |
| <input type="checkbox"/> Power cord with twist-lock plug | <input type="checkbox"/> 115V single phase |
| <input type="checkbox"/> Longer hydraulic hose length | |
| <input type="checkbox"/> 50,000 lbs. rollover capacity (lowered height + 2") | |

** Any additions, deletions or omissions must be corrected on this drawing, as this drawing will be considered all inclusive. **

REMOTE POWER UNIT
 Overall dimensions
 13-1/4" W x 33" L x 31" H
 (Cone w/ 8' hose)

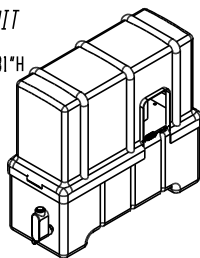
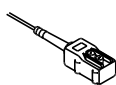

PLEASE CIRCLE SPECIFICATIONS:

MOTOR VOLTAGE	208	230	(460)
DEDICATED CIRCUIT REQUIRED			
MOTOR PHASE	- (THREE)		

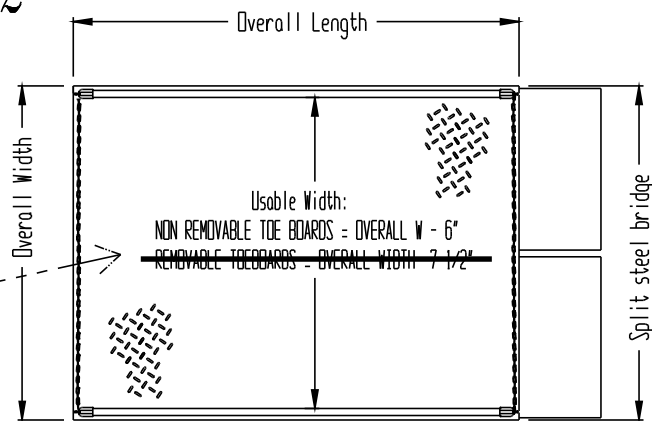

***STANDARD UNIT NOT INTENDED FOR SIDE/CROSS LOADING

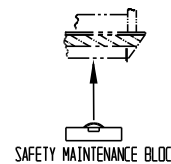
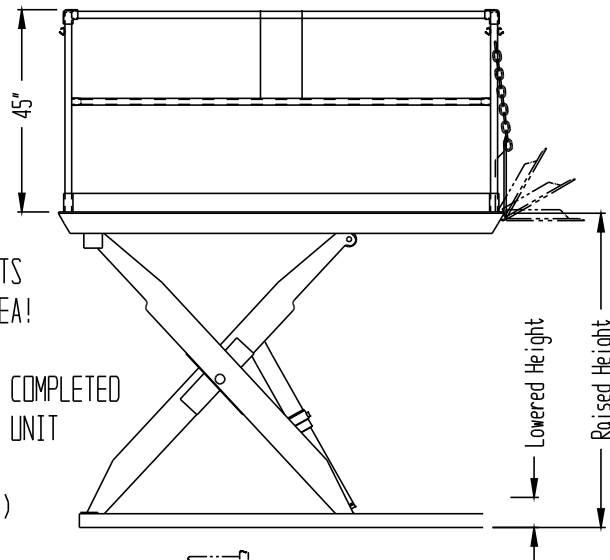

SAFETY MAINTENANCE BLOCK

PRODUCTION WILL START UPON
 RECEIPT OF SIGNED APPROVAL
 DRAWING

**SPECIAL UNITS ARE NON-RETURNABLE
 *AVAILABLE AT ADDITIONAL COSTS

All graphics provided are for reference only.
 If certain dimensions are critical please
 verify those dimensions with your salesperson

I, THE UNDERSIGNED, AGREE THAT THE PRODUCT AS REPRESENTED
 SATISFIES DESIGN & DIMENSION REQUIREMENTS. I ALSO ACKNOWLEDGE
 MY DUTY TO CONFIRM PRODUCT & INSTALLATION COMPLIANCE WITH ALL
 APPLICABLE FEDERAL, STATE AND LOCAL REGULATIONS & STANDARDS.
ALL SPECIAL UNITS ARE NON-RETURNABLE
 () As drawn () As marked
 Signed: _____ Date: _____
 LEAD TIME WILL START UPON RECEIPT OF SIGNED APPROVAL DRAWING

DISTRIBUTOR'S NAME: VESTIL MANUFACTURING		P.O.#: -
DRAWN BY: -		V.O.#: -
DATE: -	SALES: -	
REFERENCE: -	SCALE: 1:40	DRWG. FILE NAME:
QUOTED LEADTIME: -	QUOTE #: -	05-007-025-002