

WIRE SPOOL RACK W/ WHEELS & HANDLE KIT - WIRE-D-WHK

APPROX WEIGHT: 63.91 lbs.
 DOES NOT INCLUDE WEIGHT OF POWER OR PACKAGING!!!

*** ANY ADDITIONS, DELETIONS, OR OMISSIONS MUST BE CORRECTED ON THIS DRAWING AS THIS DRAWING WILL BE CONSIDERED ALL INCLUSIVE ***

ALL GRAPHICS PROVIDED ARE FOR REFERENCE ONLY. IF CERTAIN DIMENSIONS ARE CRITICAL PLEASE VERIFY THOSE DIMENSIONS WITH YOUR SALESPERSON

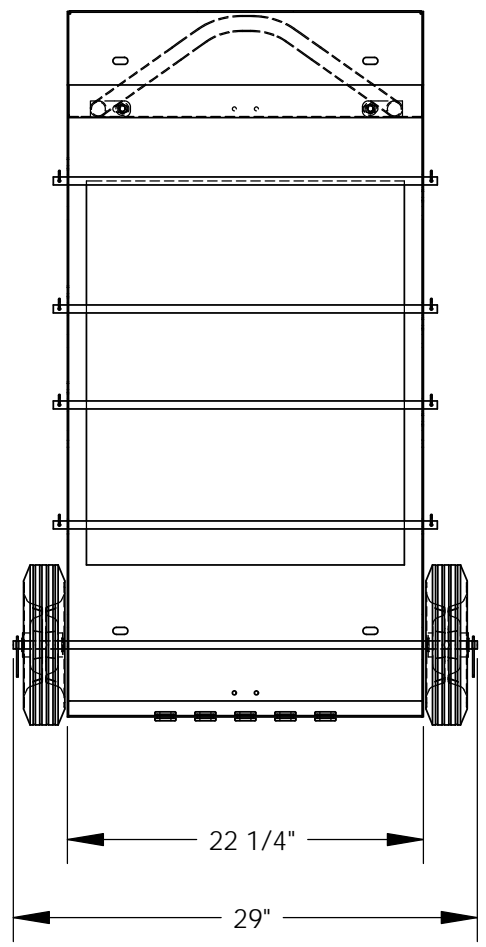

STANDARD FEATURES

MODEL NUMBER: WIRE-D-WHK
 UNIT HAS 2 HOLES FOR HANDLE HEIGHT
 OVERALL HEIGHT WITH HANDLE IN UPPER POSITION: 47 5/16"
 OVERALL HEIGHT WITH HANDLE IN LOWER: 44 9/16"
 OVERALL LENGTH: 21 7/8"
 OVERALL WIDTH: 29"
 UNIT COMES WITH 4 WIRE SPOOL AXLES
 CAPACITY = 300 LBS
 100 LBS PER SPOOL AXLE

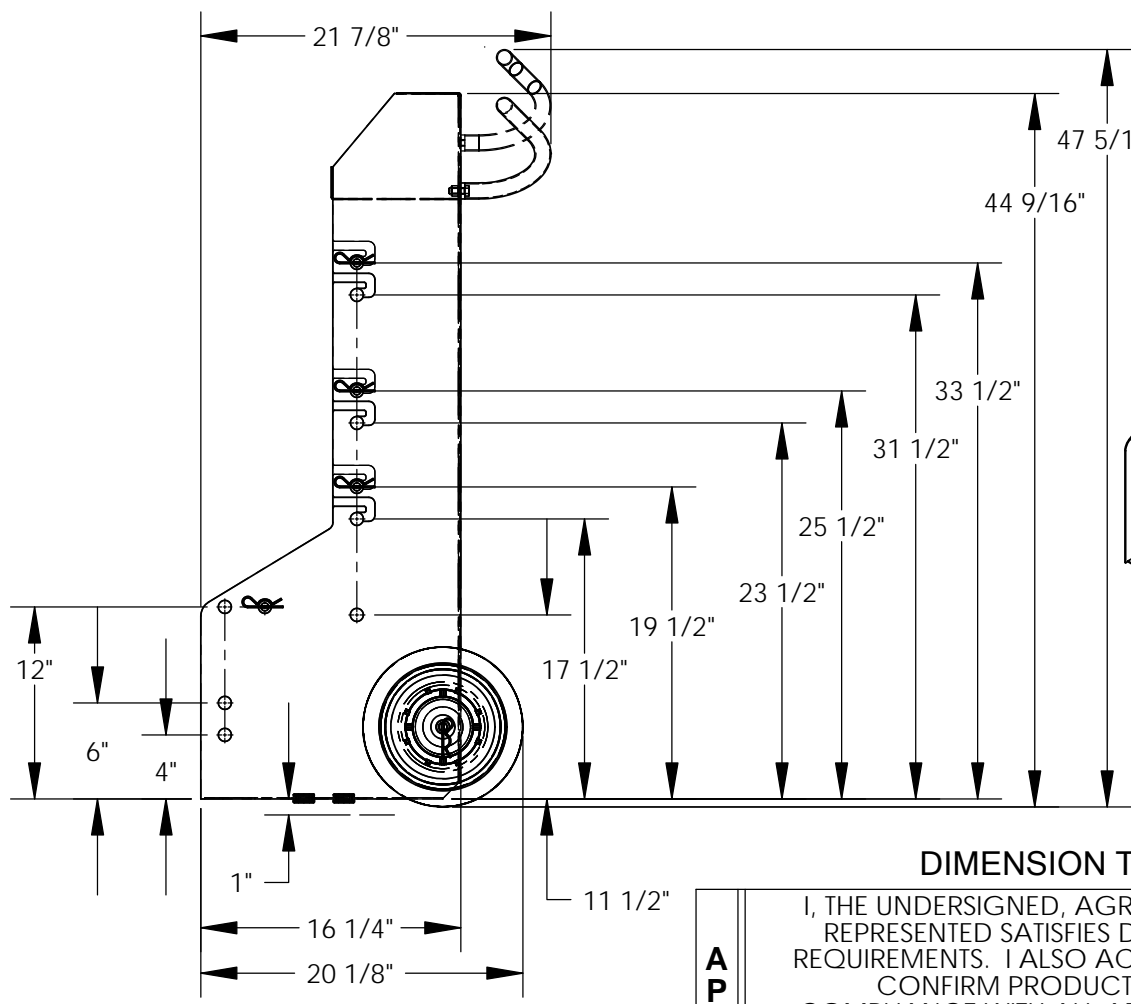

SPECIAL FEATURES

NONE

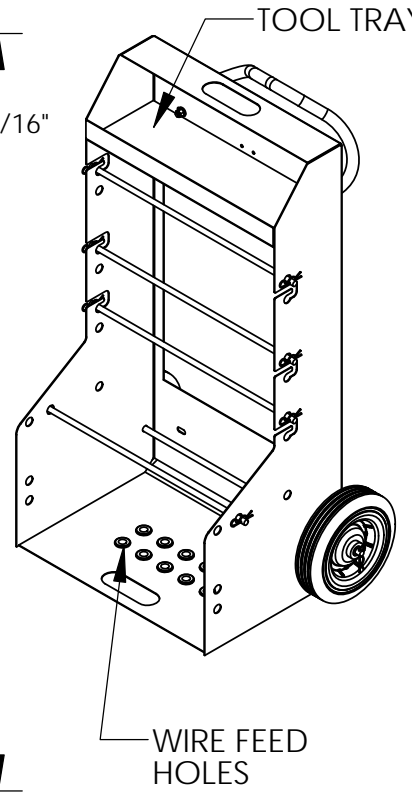

DIMENSION TOLERANCE ± 1/4"

APPROVAL

I, THE UNDERSIGNED, AGREE THAT THE PRODUCT AS REPRESENTED SATISFIES DESIGN AND DIMENSION REQUIREMENTS. I ALSO ACKNOWLEDGE MY DUTY TO CONFIRM PRODUCT AND INSTALLATION COMPLIANCE WITH ALL APPLICABLE FEDERAL, STATE AND LOCAL REGULATIONS AND STANDARDS.
ALL SPECIAL UNITS ARE NON-RETURNABLE
 As drawn As marked

Signed: _____ Date: _____

LEAD TIME WILL START UPON RECEIPT OF SIGNED APPROVAL DRAWING

FOR INTERNAL USE ONLY PROJECT SIGN OFF	
SALES	
ENG.	
FAB.	
POWER	

DISTRIBUTOR'S NAME: VESTIL MANUFACTURING		P.O.# X
DRAWN BY: KY		W.O.# X
DATE: 9/13/2005	SALES: X	
REFERENCE: X	SCALE: 1:12	FILE NAME:
QUOTED LEAD TIME: X	QUOTE # X	31-007-077-001