

HYDRAULIC VEHICLE POSITIONING JACK - VPJ-12

APPROX WEIGHT: 58.37 lbs.
 DOES NOT INCLUDE WEIGHT OF POWER OR PACKAGING!!!

*** ANY ADDITIONS, DELETIONS, OR OMISSIONS MUST BE CORRECTED ON THIS DRAWING AS THIS DRAWING WILL BE CONSIDERED ALL INCLUSIVE ***

ALL GRAPHICS PROVIDED ARE FOR REFERENCE ONLY. IF CERTAIN DIMENSIONS ARE CRITICAL PLEASE VERIFY THOSE DIMENSIONS WITH YOUR SALESPERSON

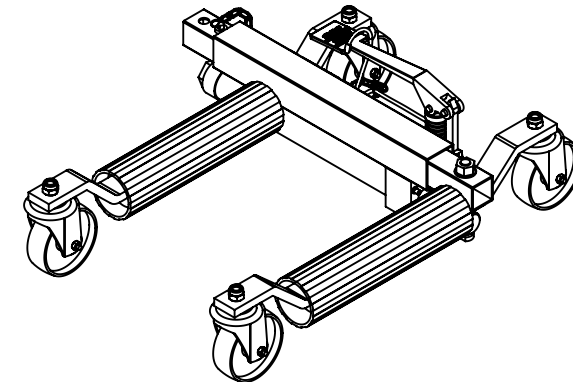
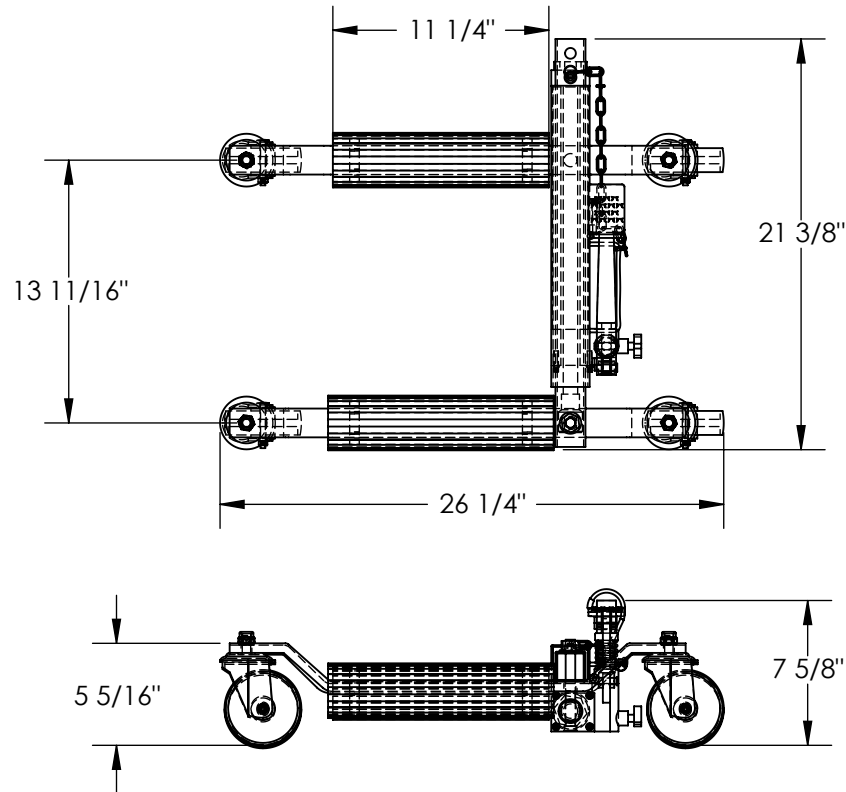

STANDARD FEATURES

- MODEL NUMBER IS VPJ-12
- OVERALL WIDTH IS 21 3/8"
- MAXIMUM TIRE WIDTH IS 12"
- OVERALL LENGTH IS 26 1/4"
- OVERALL HEIGHT IS 7 5/8"
- UNIFORM STATIC CAPACITY IS 1500 LBS.
- UNIT WILL OPEN FROM 13 11/16" TO 24 11/16"
- WHEEL SIZE IS Ø4" X 1 1/4" WIDE ON A 360° SWIVEL CASTER
- UNIT HAS A FOOT OPERATED PUMP

SPECIAL FEATURES

NONE

| | | |
|--|--|-------------|
| APPROVAL | I, THE UNDERSIGNED, AGREE THAT THE PRODUCT AS REPRESENTED SATISFIES DESIGN AND DIMENSION REQUIREMENTS. I ALSO ACKNOWLEDGE MY DUTY TO CONFIRM PRODUCT AND INSTALLATION COMPLIANCE WITH ALL APPLICABLE FEDERAL, STATE AND LOCAL REGULATIONS AND STANDARDS. | |
| | ALL SPECIAL UNITS ARE NON-RETURNABLE | |
| | [] As drawn [] As marked | |
| Signed: _____ | | Date: _____ |
| LEAD TIME WILL START UPON RECEIPT OF SIGNED APPROVAL DRAWING | | |

| | | |
|----------------------|-------------|------------|
| DISTRIBUTOR'S NAME: | | P.O.# |
| VESTIL MANUFACTURING | | X |
| DRAWN BY: DEY | | W.O.# |
| DATE: 8/31/10 | | X |
| REFERENCE: X | SCALE: 1:10 | SALES: X |
| QUOTED LEAD TIME: X | QUOTE # | FILE NAME: |
| | X | 30-007-183 |