

STAINLESS STEEL TILT MASTER - ULM-TM-15-2331

APPROX WEIGHT: 340 lbs.
 DOES NOT INCLUDE WEIGHT OF POWER OR PACKAGING!!!

*** ANY ADDITIONS, DELETIONS, OR OMISSIONS MUST BE CORRECTED ON THIS DRAWING AS THIS DRAWING WILL BE CONSIDERED ALL INCLUSIVE ***
 ALL GRAPHICS PROVIDED ARE FOR REFERENCE ONLY. IF CERTAIN DIMENSIONS ARE CRITICAL PLEASE VERIFY THOSE DIMENSIONS WITH YOUR SALESPERSON

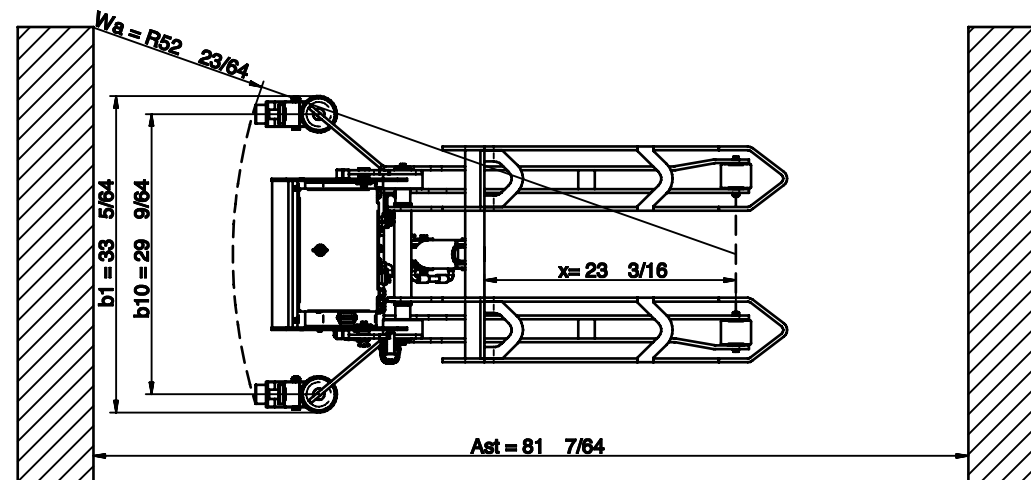
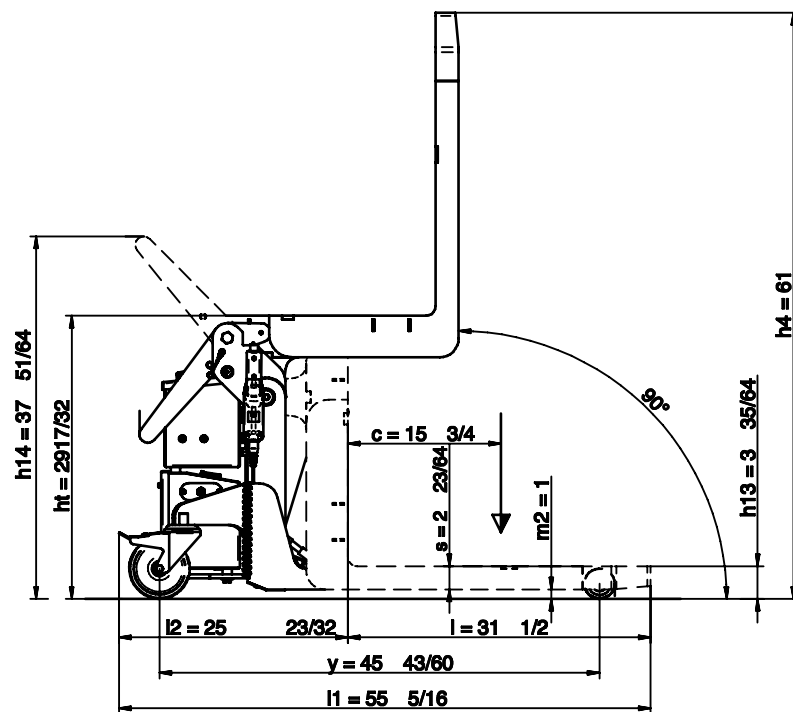

DIMENSION TOLERANCE $\pm 1/2''$

FEATURES

- MODEL NO: ULM-TM-15-2331
- CAPACITY: 1,500 LBS
- OVERALL LENGTH: 55 5/16"
- OVERALL WIDTH: 33 1/16"
- LOWERED FORK HEIGHT: 3 9/16"
- LEVEL HEIGHT: 29 1/2"
- RAISED HEIGHT: 61"
- FORK SIZE: 6 1/8"W X 31 1/2"L
- 12V DC POWER
- STAINLESS STEEL CONSTRUCTION

APPROVAL

I, THE UNDERSIGNED, AGREE THAT THE PRODUCT AS REPRESENTED SATISFIES DESIGN AND DIMENSION REQUIREMENTS. I ALSO ACKNOWLEDGE MY DUTY TO CONFIRM PRODUCT AND INSTALLATION COMPLIANCE WITH ALL APPLICABLE FEDERAL, STATE AND LOCAL REGULATIONS AND STANDARDS.

UNITS REQUIRING APPROVAL DRAWINGS OR MODIFIED ARE NON-RETURNABLE

[] As drawn [] As marked

Signed: _____ Date: _____

Printed Name: _____

LEAD TIME WILL START UPON RECEIPT OF SIGNED APPROVAL DRAWING

FOR INTERNAL USE ONLY PROJECT SIGN OFF	
SALES	
ENG.	
FAB.	
POWER	

DISTRIBUTOR'S NAME:		P.O.#
VESTIL MANUFACTURING		X
W.O.#		X
DRAWN BY: TM	DATE: 6/12/2020	SALES: X
REFERENCE: X	SCALE: 1:2	FILE NAME:
QUOTED LEAD TIME: X	QUOTE # X	ULM-TM-15-2331