

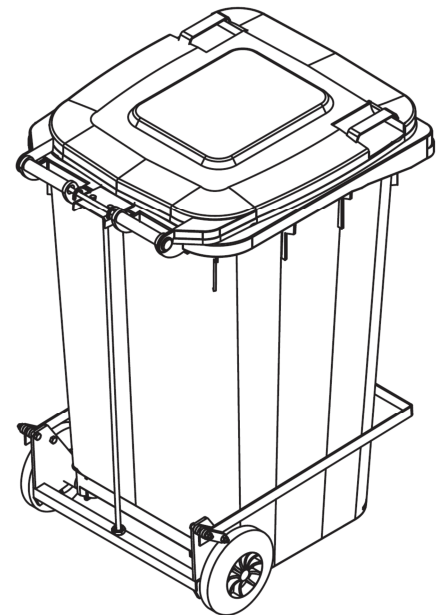

VESTIL MANUFACTURING CORP.
 2999 North Wayne Street, P.O. Box 507, Angola, IN 46703
 Telephone: (260) 665-7586 -or- Toll Free (800) 348-0868
 Fax: (260) 665-1339
www.vestilmfg.com

Assembly Instructions: TH-64-XX-FL Trash Can With Foot Pedal Lid Lifter

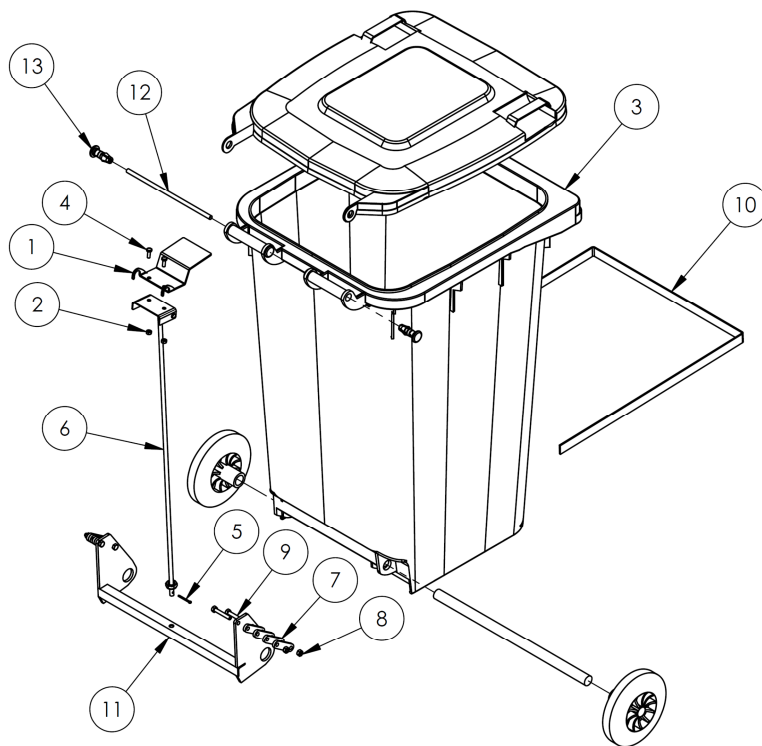

NOTE: Trash can design is subject to change without notice.
 The trash can you receive might not look exactly like the trash can shown in these instructions

Item No.	Part No.	Description	QTY
1	30-016-028	Bracket, Lid Lifter	1
2	36102	Nut, Hex nut Z plated, ¼ - 20	2
3	30-001-171	Assembly, trash can, 64 gal.	1
4	11003	Bolt, ¼ - 20 UNC x ¾ LG	2
5	65078	Cotter Pin Z Plated, ¼-20	2
6	30-514-022	Weldment, Lid Lifting	1
7	30-113-008	Shim, Foot Pedal	8
8	36104	Hex Nut Z Plated, 5/16 -18	4
9	11061	HHCS #2 Z Plated, 5/16- 18 x 2 LG	4
10	30-014-047	Frame, Foot Pedal	1
11	30-514-030	Weldment, Axle Bracket	1
12	30-112-014	Center Bar	1
13	30-001-172-C	Handle Plug	2

NOTE: Numbers in parentheses refer to item numbers in the table on p1.

STEP 1 Attach Weldment (11)

- Align axle holes in weldment with axle channel (refer to exploded diagram on front page) in the base of the trash bin
- Insert axle through weldment holes and axle channel

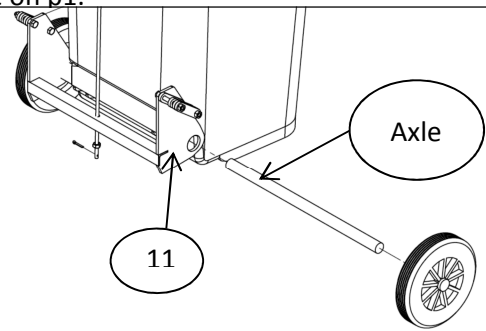

STEP 2 Attach wheels to ends of the axle

- Press wheels onto the ends of the axle until they latch onto the axle. (Pins inside the axle receiver of each wheel hold onto grooves milled into the axle.)

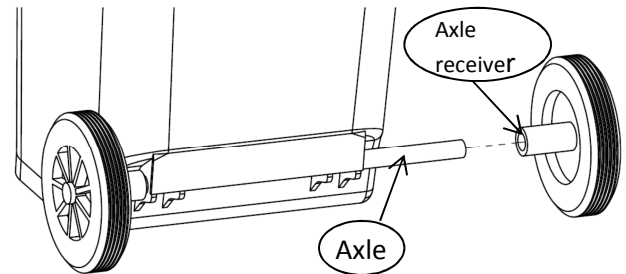

STEP 3: Attach foot lever (10) to axle bracket weldment

- Fasten foot pedal shims (7) to the weldment using nuts (8) & bolts (9) as shown in the diagram to the right. Do not tighten these connections yet.
- Insert foot lever (10) around trash bin, then insert the ends of the pedal under the shims & between the bolts.

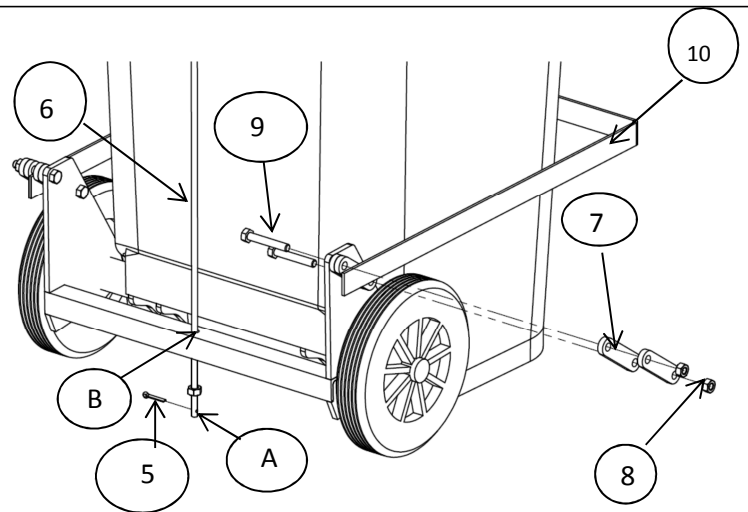

STEP 4: Connect lid lifting weldment (6) to axle bracket weldment

- Insert end "A" through hole "B" in the center of the bracket weldment
- Secure the connection with a cotter pin (#5) through the end of the lifting weldment

STEP 5: Connect lid lifter bracket (1)

- Connect lid lifter bracket (1) to lid lifting bar (6) with 1/4 bolt (4) & hex nut (2)

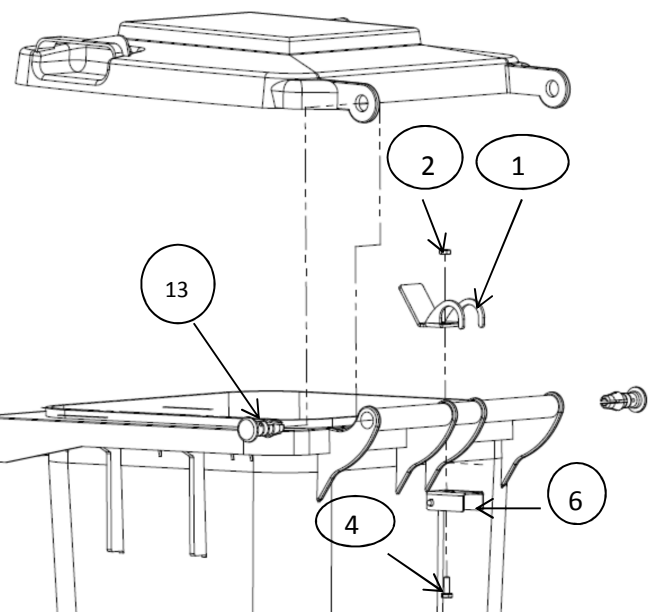

STEP 6: Attach lid

- Place lid over top of bracket (1).
- Align handle brackets with handle & insert the handle plugs (13).