

# ELECTRIC HYDRAULIC TRASH CAN DUMPER - TCD-M-48-DC

APPROX WEIGHT: 556.89 lbs.  
 DOES NOT INCLUDE WEIGHT OF POWER OR PACKAGING!!!

\*\*\* ANY ADDITIONS, DELETIONS, OR OMISSIONS MUST BE CORRECTED ON THIS DRAWING AS THIS DRAWING WILL BE CONSIDERED ALL INCLUSIVE \*\*\*  
 ALL GRAPHICS PROVIDED ARE FOR REFERENCE ONLY. IF CERTAIN DIMENSIONS ARE CRITICAL PLEASE VERIFY THOSE DIMENSIONS WITH YOUR SALESPERSON

## STANDARD FEATURES

MODEL NUMBER: TCD-M-48-DC  
 USABLE CHUTE WIDTH: 20" MIN TO 27" MAX  
 USAGE CHUTE LENGTH: 27 1/8"

OVERALL LENGTH: 75 5/8"  
 OVERALL WIDTH: 46 1/16"  
 OVERALL HEIGHT: 64 11/16"

OVERALL ROTATED HEIGHT: 113 15/16"  
 MAXIMUM ROTATED ANGLE: 45°  
 DUMP HEIGHT: 48 7/8"

WORKS WITH MODEL# TH-32/64/95

UNIFORM CAPACITY IS 400 LBS  
 CASTERS:  
 FRONT: 8" X 2" GFN SWIVEL  
 REAR: 8" X 2" GFN RIGID  
 TWO ADJUSTABLE FLOOR LOCKS  
 INTERNAL POWER UNIT: 12 V DC WITH  
 ON-BOARD CHARGER  
 CONTROL IS HANDHELD, 2 BUTTON, NEMA 4  
 PENDANT WITH MINIMUM 8' USABLE COIL CORD

FRAME: DURABLE LIQUID PAINT BLUE FINISH  
 CHUTE: DURABLE LIQUID PAINT YELLOW FINISH

## SPECIAL FEATURES

NONE

DIMENSION TOLERANCE ± 1/4"

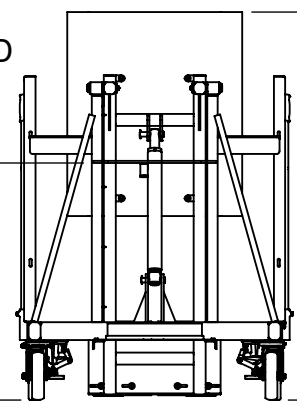
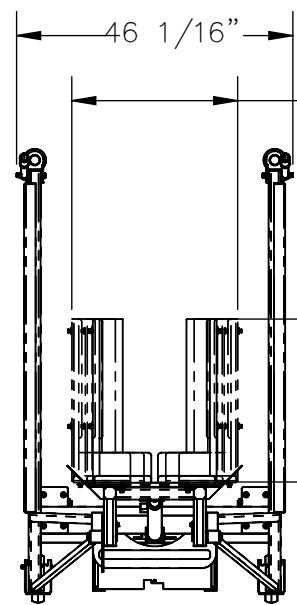

20" MIN  
27" MAX

27 1/8"

113 15/16"

64 11/16"

39 1/2"

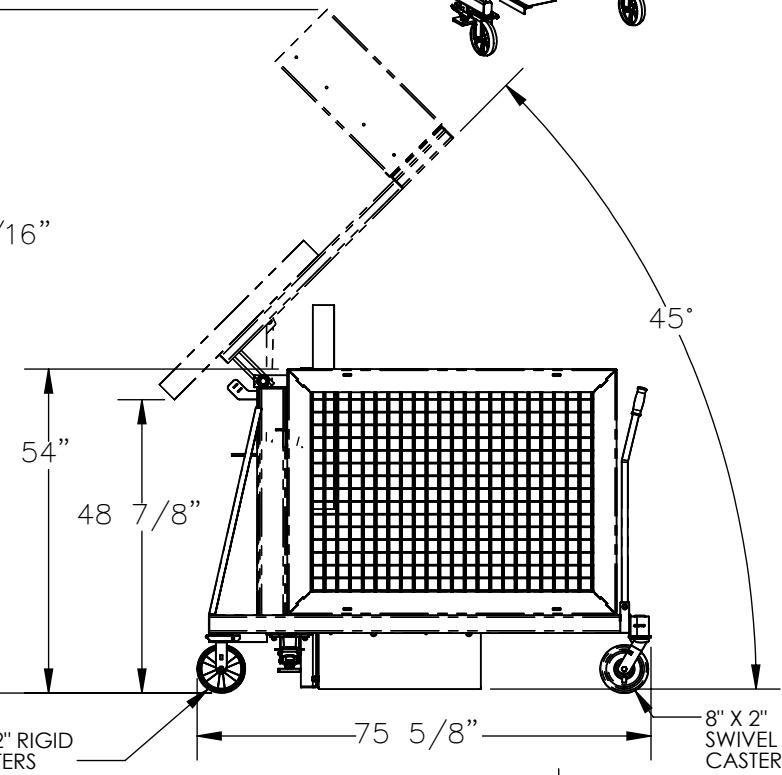
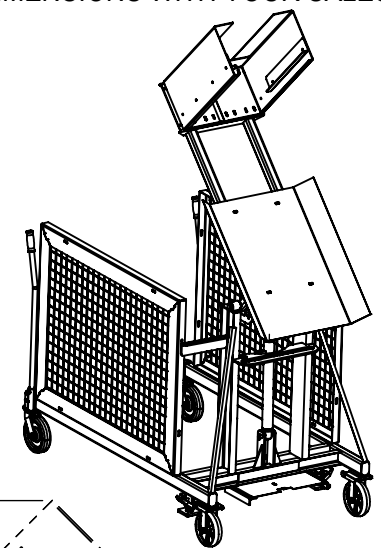

45°

8" X 2" RIGID CASTERS

8" X 2" SWIVEL CASTERS

APPROVAL

I, THE UNDERSIGNED, AGREE THAT THE PRODUCT AS REPRESENTED SATISFIES DESIGN AND DIMENSION REQUIREMENTS. I ALSO ACKNOWLEDGE MY DUTY TO CONFIRM PRODUCT AND INSTALLATION COMPLIANCE WITH ALL APPLICABLE FEDERAL, STATE AND LOCAL REGULATIONS AND STANDARDS.

**UNITS REQUIRING APPROVAL DRAWINGS OR MODIFIED ARE NON-RETURNABLE**

As drawn       As marked

Signed: \_\_\_\_\_ Date: \_\_\_\_\_

Printed Name: \_\_\_\_\_

LEAD TIME WILL START UPON RECEIPT OF SIGNED APPROVAL DRAWING

DISTRIBUTOR'S NAME: <b>VESTIL MANUFACTURING</b>		P.O.# X
DRAWN BY: SJA		DATE: 7/28/2016
REFERENCE: X	SCALE: 1:36	SALES: X
QUOTED LEAD TIME: X	QUOTE # X	FILE NAME: 34-007-015