

STEEL WHEEL CHOCK - SWC-22

APPROX WEIGHT: 18.76 lbs.
DOES NOT INCLUDE WEIGHT OF POWER OR PACKAGING!!!

*** ANY ADDITIONS, DELETIONS, OR OMISSIONS MUST BE CORRECTED ON THIS DRAWING AS THIS DRAWING WILL BE CONSIDERED ALL INCLUSIVE ***

ALL GRAPHICS PROVIDED ARE FOR REFERENCE ONLY. IF CERTAIN DIMENSIONS ARE CRITICAL PLEASE VERIFY THOSE DIMENSIONS WITH YOUR SALESPERSON

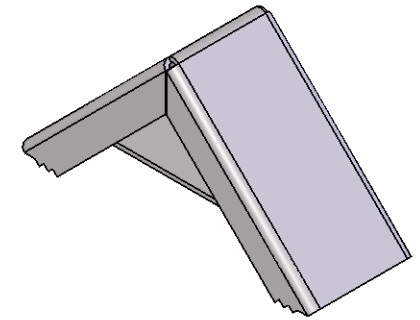
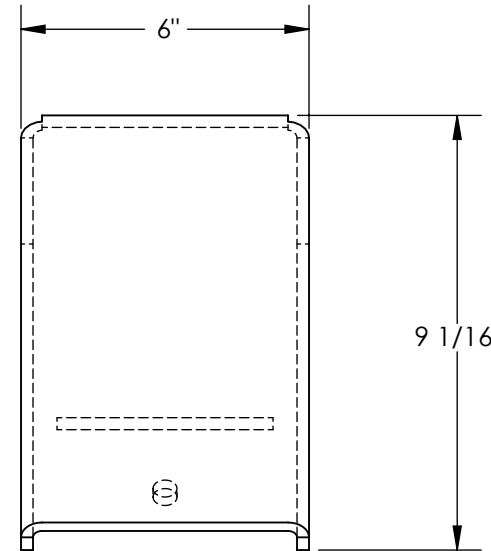
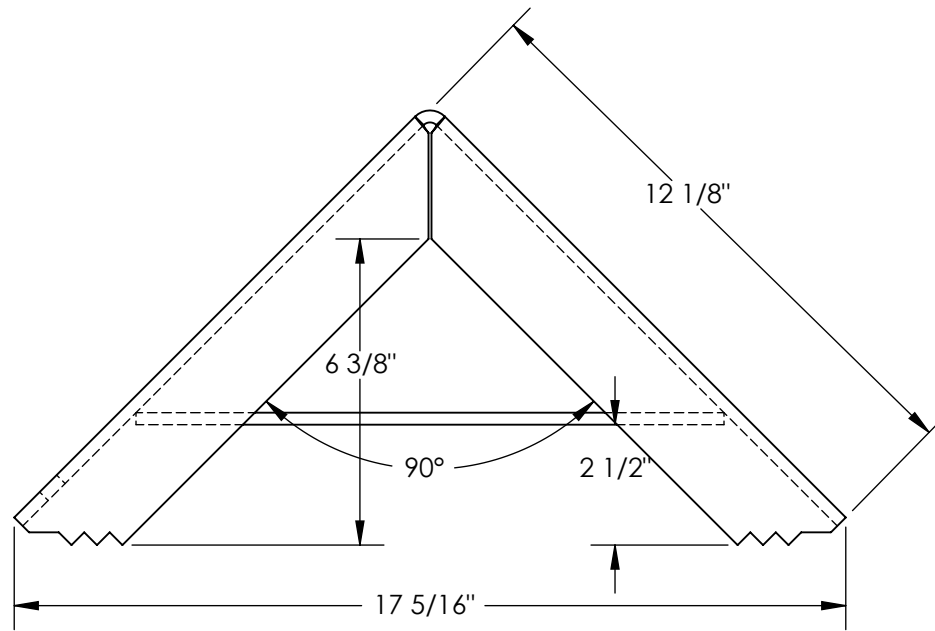

STANDARD FEATURES

MODEL NUMBER IS SWC-22
OVERALL WIDTH IS 6"
OVERALL LENGTH IS 17 5/16"
OVERALL HEIGHT IS 9 1/16"
ALL WELDED STEEL CONSTRUCTION
PAINTED SAFETY YELLOW

SPECIAL FEATURES

NONE

A P P R O V A L	I, THE UNDERSIGNED, AGREE THAT THE PRODUCT AS REPRESENTED SATISFIES DESIGN AND DIMENSION REQUIREMENTS. I ALSO ACKNOWLEDGE MY DUTY TO CONFIRM PRODUCT AND INSTALLATION COMPLIANCE WITH ALL APPLICABLE FEDERAL, STATE AND LOCAL REGULATIONS AND STANDARDS.	
	ALL SPECIAL UNITS ARE NON-RETURNABLE [] As drawn [] As marked	
	Signed: _____ Date: _____	
LEAD TIME WILL START UPON RECEIPT OF SIGNED APPROVAL DRAWING		

DISTRIBUTOR'S NAME: VESTIL MANUFACTURING		P.O.# X
DRAWN BY: JB		W.O.# X
DATE: 6/23/09	SCALE: 1:4	SALES: X
REFERENCE: X	QUOTE # X	FILE NAME: 23-007-313