

STEEL TREADPLATE TOOLBOX W/FORK POCKETS & CASTERS- STTB-3060-CF

APPROX WEIGHT: 377.20 lbs.
DOES NOT INCLUDE WEIGHT OF POWER OR PACKAGING!!!

*** ANY ADDITIONS, DELETIONS, OR OMISSIONS MUST BE CORRECTED ON THIS DRAWING AS THIS DRAWING WILL BE CONSIDERED ALL INCLUSIVE ***
ALL GRAPHICS PROVIDED ARE FOR REFERENCE ONLY. IF CERTAIN DIMENSIONS ARE CRITICAL PLEASE VERIFY THOSE DIMENSIONS WITH YOUR SALESPERSON

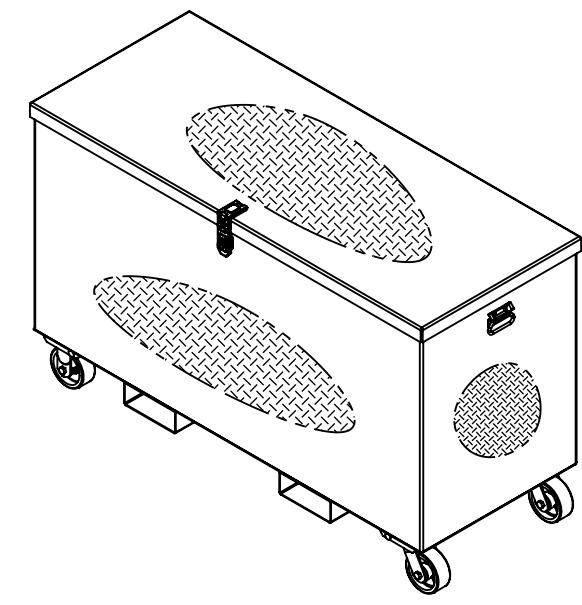
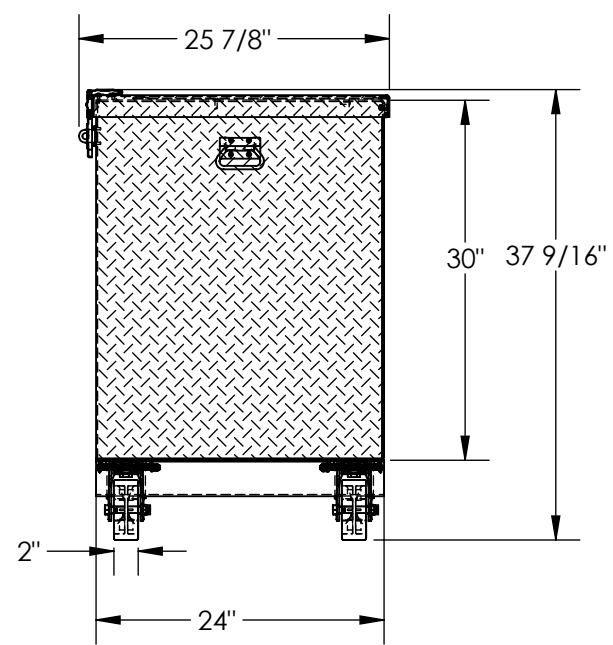
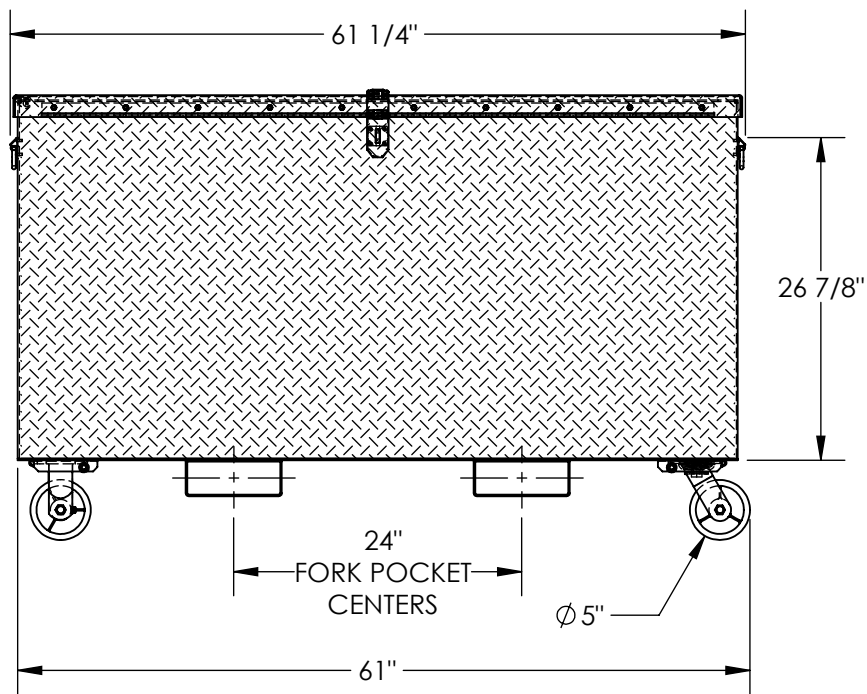

DIMENSION TOLERANCE ± 1/4"

STANDARD FEATURES

- MODEL NUMBER IS STTB-3060-CF
- OVERALL WIDTH IS 61 1/4"
- USABLE WIDTH IS 61"
- OVERALL DEPTH IS 25 7/8"
- USABLE DEPTH IS 24"
- OVERALL HEIGHT IS 37 9/16"
- USABLE HEIGHT IS 30"
- MAX CAPACITY IS 3000 LBS.
- TOUGH BAKED IN POWDER COAT BLACK FINISH
- 24" FORK POCKET CENTERS
- CASTERS ARE 5" x 2" POLY ON STEEL
- 2 SWIVEL, 2 RIGID

SPECIAL FEATURES

NONE

APPROVAL	I, THE UNDERSIGNED, AGREE THAT THE PRODUCT AS REPRESENTED SATISFIES DESIGN AND DIMENSION REQUIREMENTS. I ALSO ACKNOWLEDGE MY DUTY TO CONFIRM PRODUCT AND INSTALLATION COMPLIANCE WITH ALL APPLICABLE FEDERAL, STATE AND LOCAL REGULATIONS AND STANDARDS.	
	UNITS REQUIRING APPROVAL DRAWINGS OR MODIFIED ARE NON-RETURNABLE	
	[] As drawn	[] As marked
Signed: _____		Date: _____
Printed Name: _____		
<i>LEAD TIME WILL START UPON RECEIPT OF SIGNED APPROVAL DRAWING</i>		

DISTRIBUTOR'S NAME:		P.O.#
VESTIL MANUFACTURING		X
		W.O.#
DRAWN BY: C.CLEMENS		X
DATE: 1/5/2021		SALES:
REFERENCE: X		FILE NAME:
SCALE: 1:16		41-007-057
QUOTED LEAD TIME: X	QUOTE #	
	X	