

# STEEL TREADPLATE TOOLBOX W/CASTERS - STTB-2460-C

APPROX WEIGHT: 305.51 lbs.  
 DOES NOT INCLUDE WEIGHT OF POWER OR PACKAGING!!!

\*\*\* ANY ADDITIONS, DELETIONS, OR OMISSIONS MUST BE CORRECTED ON THIS DRAWING AS THIS DRAWING WILL BE CONSIDERED ALL INCLUSIVE \*\*\*  
 ALL GRAPHICS PROVIDED ARE FOR REFERENCE ONLY. IF CERTAIN DIMENSIONS ARE CRITICAL PLEASE VERIFY THOSE DIMENSIONS WITH YOUR SALESPERSON

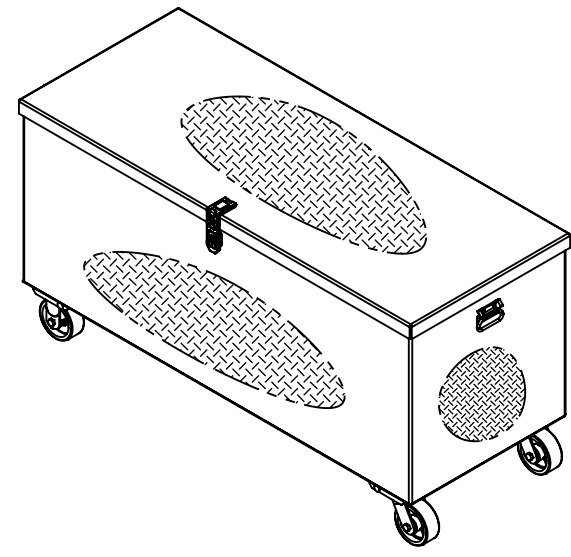
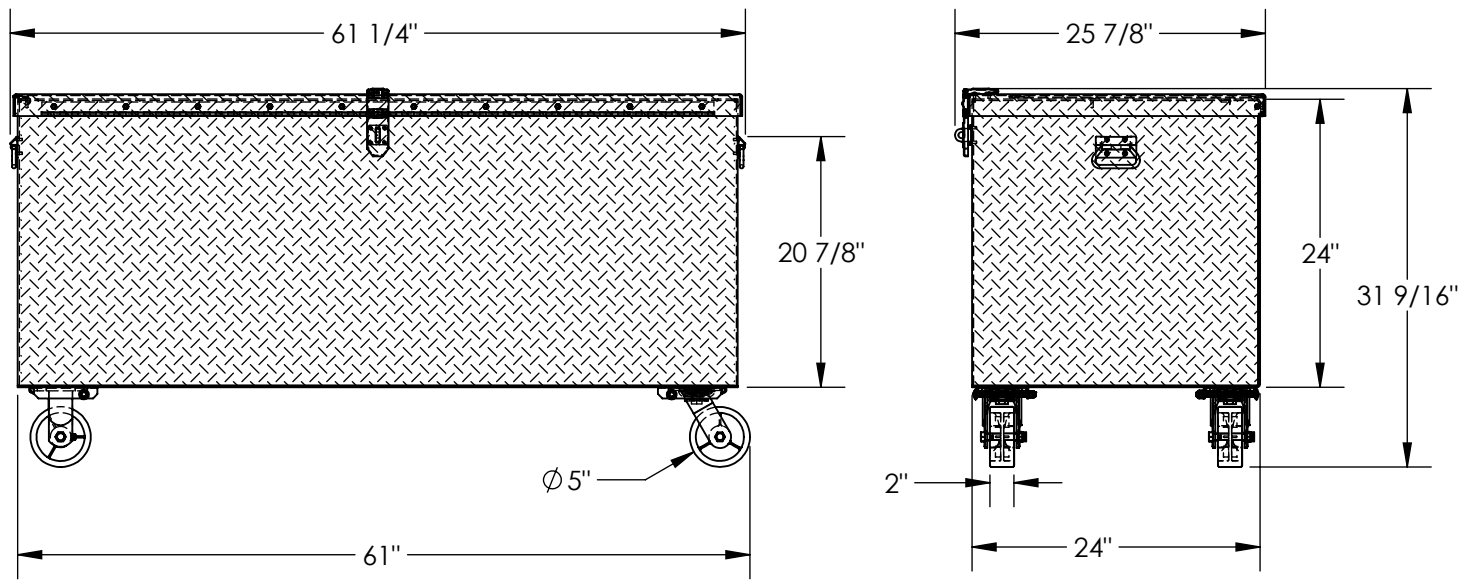

DIMENSION TOLERANCE ± 1/4"

## STANDARD FEATURES

- MODEL NUMBER IS STTB-2460-C
- OVERALL WIDTH IS 61 1/4"
- USABLE WIDTH IS 61"
- OVERALL DEPTH IS 25 7/8"
- USABLE DEPTH IS 24"
- OVERALL HEIGHT IS 31 9/16"
- USABLE HEIGHT IS 24"
- MAX CAPACITY IS 3000 LBS.
- TOUGH BAKED IN POWDER COAT BLACK FINISH
- CASTERS ARE 5" x 2" POLY ON STEEL
- 2 SWIVEL, 2 RIGID

## SPECIAL FEATURES

NONE

**APPROVAL**

I, THE UNDERSIGNED, AGREE THAT THE PRODUCT AS REPRESENTED SATISFIES DESIGN AND DIMENSION REQUIREMENTS. I ALSO ACKNOWLEDGE MY DUTY TO CONFIRM PRODUCT AND INSTALLATION COMPLIANCE WITH ALL APPLICABLE FEDERAL, STATE AND LOCAL REGULATIONS AND STANDARDS.

**UNITS REQUIRING APPROVAL DRAWINGS OR MODIFIED ARE NON-RETURNABLE**

As drawn       As marked

Signed: \_\_\_\_\_ Date: \_\_\_\_\_

Printed Name: \_\_\_\_\_

*LEAD TIME WILL START UPON RECEIPT OF SIGNED APPROVAL DRAWING*

DISTRIBUTOR'S NAME:		P.O.#
VESTIL MANUFACTURING		X
DRAWN BY: C.CLEMENS		DATE: 1/5/2021
REFERENCE: X		SCALE: 1:16
QUOTED LEAD TIME: X		QUOTE # X
		SALES: X
		FILE NAME: 41-007-051