

HEAVY DUTY STACKABLE MATERIAL CART, V-BOTTOM - SPC-3654-VB

APPROX WEIGHT: 216.10 lbs.
 DOES NOT INCLUDE WEIGHT OF POWER OR PACKAGING!!!

*** ANY ADDITIONS, DELETIONS, OR OMISSIONS MUST BE CORRECTED ON THIS DRAWING AS THIS DRAWING WILL BE CONSIDERED ALL INCLUSIVE ***
 ALL GRAPHICS PROVIDED ARE FOR REFERENCE ONLY. IF CERTAIN DIMENSIONS ARE CRITICAL PLEASE VERIFY THOSE DIMENSIONS WITH YOUR SALESPERSON

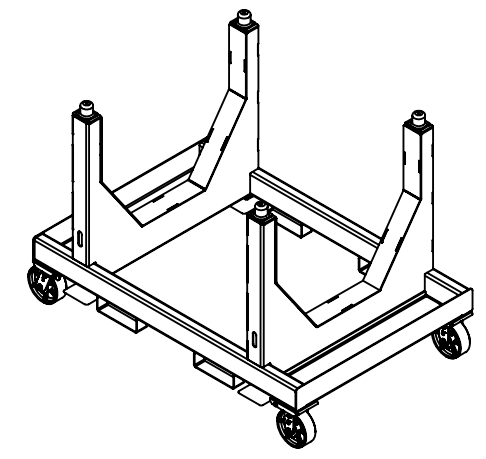
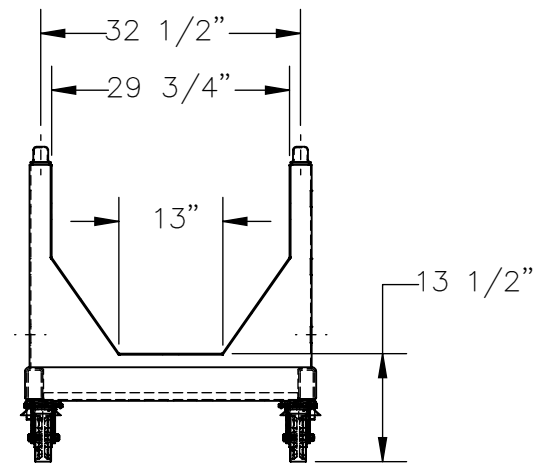
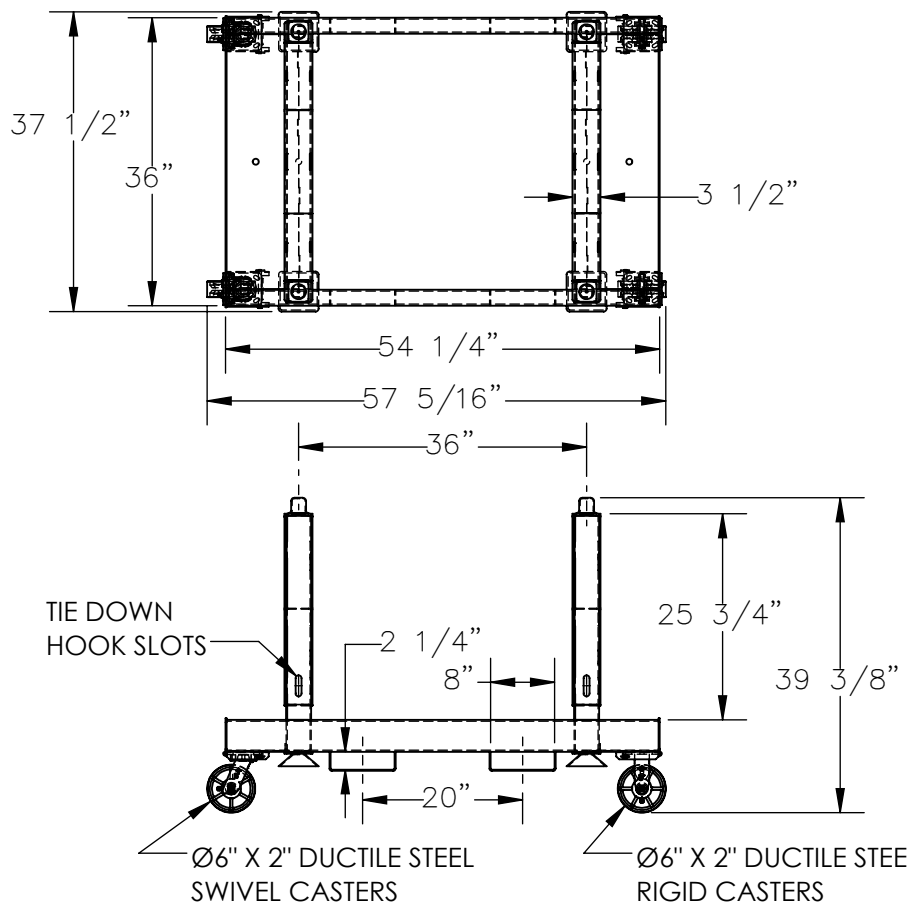

DIMENSION TOLERANCE ± 1/4"

STANDARD FEATURES

- MODEL NUMBER IS: SPC-3654-VB
- MAX CAPACITY IS: 5,000 LBS
- OVERALL WIDTH IS: 37 1/2"
- USABLE WIDTH IS: 29 3/4"
- OVERALL LENGTH IS: 57 5/16"
- USABLE LENGTH IS: 54 1/4"
- OVERALL HEIGHT IS: 39 3/8"
- V-BOTTOM HEIGHT IS: 13 1/2"
- V-BOTTOM WIDTH IS: 13"
- FORK POCKETS ARE: 2 1/4" X 8" ON 20" CENTERS
- (2) RIGID 6"X2" DUCTILE STEEL CASTERS
- (2) SWIVEL 6"X2" DUCTILE STEEL CASTERS
- FOR STORAGE: EMPTY CARTS CAN BE STACKED 3 HIGH
- DO NOT** EXCEED MAX MATERIAL HEIGHT OF: 25 3/4"
- TOUGH BAKED IN POWDER COATED BLUE FINISH

SPECIAL FEATURES

NONE

APPROVAL

I, THE UNDERSIGNED, AGREE THAT THE PRODUCT AS REPRESENTED SATISFIES DESIGN AND DIMENSION REQUIREMENTS. I ALSO ACKNOWLEDGE MY DUTY TO CONFIRM PRODUCT AND INSTALLATION COMPLIANCE WITH ALL APPLICABLE FEDERAL, STATE AND LOCAL REGULATIONS AND STANDARDS.
UNITS REQUIRING APPROVAL DRAWINGS OR MODIFIED ARE NON-RETURNABLE
 As drawn As marked

Signed: _____ Date: _____

Printed Name: _____

LEAD TIME WILL START UPON RECEIPT OF SIGNED APPROVAL DRAWING

DISTRIBUTOR'S NAME:		P.O.#
VESTIL MANUFACTURING		X
DRAWN BY: JGP		W.O.#
DATE: 11/23/2020		X
REFERENCE: X	SCALE: 1:24	SALES: X
QUOTED LEAD TIME: X	QUOTE #	FILE NAME:
	X	33-007-386